

DO NOT SCALE FROM THIS PRINT

TABLE 4		
LEAD STYLE	"F" RANGE	TERMINAL PIN
-03	.150-.214	T-1S15-04-X
-03	.215-.400	T-1S15-19-X
-05	.401-.525	T-1S15-20-X
-05	.526-.675	T-1S15-21-X

TABLE 2				
LEAD STYLE	OPTIONS	OVERALL HEIGHT	PACKAGING TUBE	PLUG
-03	-A-P	.150 - .650	PT-FW005-D-03-P	TP-03
-03	NONE, A	.150 - .225	PT-FW005-D-03-P	TP-03
-03	NONE, A	.226 - .309	PT-FW005-D-03-P	TP-03
-03	NONE, A	.310 - .400	PT-FW005-D-03-P	TP-03
-05	NONE, A	.310 - .800	PT-FW006-D-05-P	TP-03
-05	-A-P	.310 - .650	PT-FW006-D-05-P	TP-03
-05	-A-P	.651 - .800	PT-FW006-D-05-P	TP-03
-03, -05	-ES, -EP, -ES-A, -ES-A-P, -ES-P, -EPA, -EP-P, -EP-A-P	ALL	PT-1-24-01-71	TP-03

PACKAGING NOTE:  
TUBE POSITIONS 5-50, LAYER PACKAGE ALL OTHERS

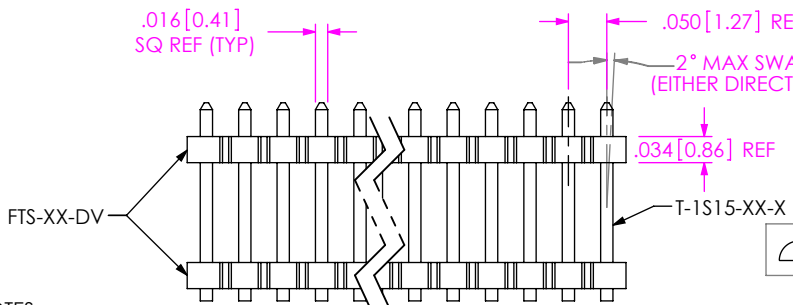
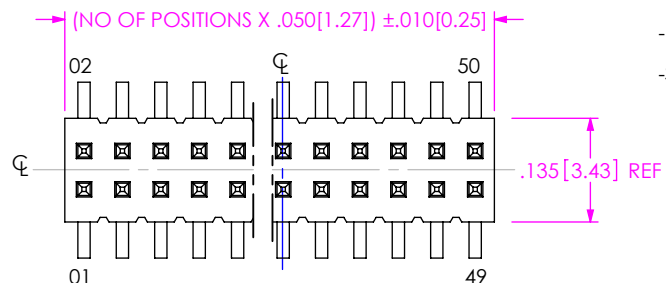

- NOTES:
- ⊕ REPRESENTS A CRITICAL DIMENSION.
  - MINIMUM PUSHOUT FORCE SHALL BE 1 LB.
  - GOLD AREA TO APPEAR ON POST.
  - TAILS TO BE SHEARED TO DIMENSION SHOWN. (FOR HAND TOOLING ONLY)
  - TO BE VALID ALL PART NUMBERS MUST MEET THE FOLLOWING PARAMETERS:  
THE BOARD SPACE RANGE, POST HEIGHT MIN. AND BOARD + POST COMBINATION FOR EACH STYLE.
  - MAXIMUM BURR: .003[0.08] ON CUT TAIL.
  - MAXIMUM CUT FLASH TO BE .010[0.25] ON CRITICAL AREAS AS SHOWN.
  - AVAILABLE ONLY W/BOARD SPACE .215[5.46] TOP .610[15.49].
  - PARTS TO BE ASSEMBLED WITH ALIGNMENT HOLES (IN BODY) FACING THE TAILS
  - LOWER BODY MAY BE BLACK OR WHITE.
  - FOR FTS-XX-DV, FILL BODY SO THAT THE LEAD IN OF THE CORE IS ON THE TAIL SIDE.
  - MAXIMUM HEIGHT VARIATION BETWEEN ROWS: .005[0.13].
  - FOR ADDED MECHANICAL STABILITY, SAMTEC RECOMMENDS MECHANICAL BOARD SPACERS BE USED IN APPLICATIONS WITH GOLD OR SELECTIVE GOLD PLATED CONNECTORS. CONTACT IPG@SAMTEC.COM FOR MORE INFORMATION.
  - NOTE DELETED.
  - TUBES ARE STANDARD PACKAGING.
  - ORDERS WILL BE PACKAGED ACCORDING TO THE SAMTEC PACKAGING EFFICIENCY STANDARDS (SPES) FOUND ON WWW.SAMTEC.COM.
  - ATTACH LABEL-4X2 TO EACH REEL.

FW-XX-XX-XX-D-XXX-XXX-XX-X-XX

POSITION SPEC  
No. OF POS PER ROW  
-02 THRU -50

LEAD STYLE  
-03: USE T-1S15-XX-X  
-05: USE T-1S15-XX-X  
(SEE TABLE 1)

PLATING

- G: 10μ" GOLD IN CONTACT AREA, 3μ" GOLD ON TAIL
- F: 3μ" SELECTIVE GOLD IN CONTACT AREA, MATTE TIN ON TAIL
- L: 10μ" SELECTIVE GOLD IN CONTACT AREA, MATTE TIN TAIL
- H: 30μ" GOLD IN CONTACT AREA, 3μ" GOLD ON TAIL
- LM: 10μ" SELECTIVE GOLD IN CONTACT AREA, MATTE TIN TAIL
- FM: 3μ" SELECTIVE GOLD IN CONTACT AREA, MATTE TIN ON TAIL
- S: 30μ" SELECTIVE GOLD IN CONTACT AREA, MATTE TIN ON TAIL

DOUBLE ROW  
(SEE TABLE 1 FOR BODY STYLE)

BOARD SPACE OPTION

(SEE NOTE 5)(SEE TABLE 1)  
-03 LEAD STYLE (.085[2.16] MIN - .335[8.51] MAX)  
-05 LEAD STYLE (.248[6.30] MIN - .610[15.49] MAX)  
MAX = "A" - POST (SEE TABLE 1)

PACKAGING

BLANK: TUBES (SEE NOTE 15)  
-TR: TAPE & REEL (SEE NOTES 16 & 17)  
-FR: FULL REEL QTY TAPE & REEL (SEE NOTES 16 & 17)  
-TR & -FR PACKAGING AVAILABLE FOR .740[18.80] MAX OVERALL HEIGHT  
MAX OVERALL HEIGHT = POST + BOARDSPACE + PAD + ALIGNMENT PIN = .740[18.80]

PICK & PLACE OPTION

-P: PICK & PLACE PAD (USE PPP-25) (USE PPP-25-NT WITH -TR & -FR ONLY) (SEE FIG 3, SHT 2) (5 POS MIN)

OPTION

- ES: END SHROUDS (SEE FIG 5, SHT 2) (9 POS PER ROW MIN)(MAX POST: .075[1.91] (SEE NOTE 8))
- EP: GUIDE POST (FIG 6, SHT 3)(SEE NOTE 8) (9 POS PER ROW MIN)(MAX POST: .075[1.91] (USE ONLY WHEN MATING WITH CLP))
- A: ALIGNMENT PIN (MOLDED OR STAKED, SAMTEC'S DISCRETION ON WHICH) (SEE FIG. 7 & 8 SHT 3)(SEE NOTE 8) (STAKED: 6 POS MIN)(MOLDED: 3 POS MIN)

POST HEIGHT (SEE NOTE 5)

.065[1.65] MIN  
POST + BOARD SPACE = "F" =  
-03: .150-.400 [3.81-10.16]  
\*.401-.675 [10.19-17.15]  
-05: \*150-.400 [3.81-10.16]  
.401-.675 [10.19-17.15]  
\* = FOR EXISTING CUSTOMERS ONLY

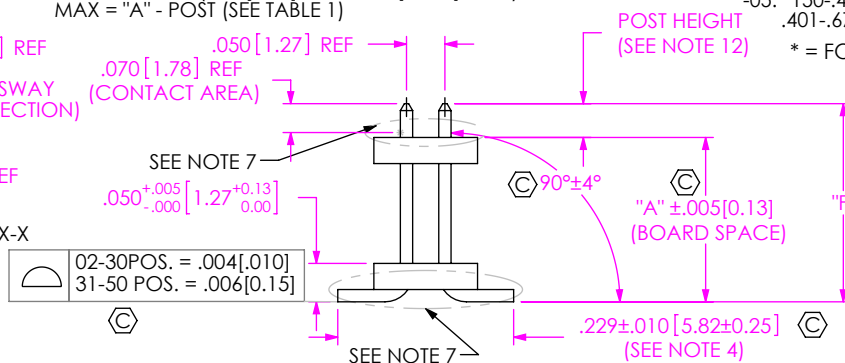

FIG 1

LEAD STYLE	"A" RANGE	"C" RANGE (SEE SHEET 2, FIG 5 & 6)	"D" RANGE (SEE SHEET 2, FIG 5 & 6)	BODY STYLE		FIG
				UPPER BODY	LOWER BODY	
-03	.085 - .214 [2.18 - 5.44]	N/A	N/A	FTS-XXDV	FTS-XXDV	1
-03	.215 - .335 [5.48 - 8.51]	.293 - .423 REF [7.45 - 10.75]	.413 - .543 REF [10.50 - 13.79]	FTSH-XX-D	*FTSH-XX-D	4 (SEE SHEET 2)
-05	.248 - .610 [6.30 - 15.49]	.326 - .698 REF [8.28 - 17.73]	.446 - .818 REF [11.32 - 20.78]	FTSH-XX-D	FTSH-XX-D	4 (SEE SHEET 2)

\* FOR BKT MACHINE, USE FW-XX-D

UNLESS OTHERWISE SPECIFIED, DIMENSIONS ARE IN INCHES.

TOLERANCES ARE:

DECIMALS ANGLES  
.XX: ±.01[0.3]  
.XXX: ±.005[0.13]  
.XXXX: ±.0020[0.051]

PROPRIETARY NOTE

THIS DOCUMENT CONTAINS CONFIDENTIAL AND PROPRIETARY INFORMATION AND ALL DESIGN, MANUFACTURING, REPRODUCTION, USE, PATENT RIGHTS AND SALES RIGHTS ARE EXPRESSLY RESERVED BY SAMTEC, INC. THIS DOCUMENT SHALL NOT BE DISCLOSED, IN WHOLE OR PART, TO ANY UNAUTHORIZED PERSON OR ENTITY NOR REPRODUCED, TRANSFERRED OR INCORPORATED IN ANY OTHER PROJECT IN ANY MANNER WITHOUT THE EXPRESS WRITTEN CONSENT OF SAMTEC, INC.



520 PARK EAST BLVD, NEW ALBANY, IN 47150  
PHONE: 812-944-6733 FAX: 812-948-5047  
e-Mail: info@SAMTEC.com code 53322

MATERIAL: DO NOT SCALE DRAWING SHEET SCALE: 4:1  
BODY: LCP, UL 94 VO, COLOR: FTS-50-DV & FTSH-50-D: BLACK  
FW-50-D: NATURAL

TERMINAL: PHOS BRONZE

MAX FLASH ALLOWED: .002[0.05]  
MAX GATE VESTIGE: .002[0.05]

F:\DWG\MISC\MKTG\FW-XX-XX-XX-D-XXX-XXX-XX-X-XX-MKT.SLDDRW

DESCRIPTION: .050 x .050 SURFACE MOUNT BOARD SPACERS

DWG. NO.

FW-XX-XX-XX-D-XXX-XXX-XX-X-XX

BY: BRATCHER 11-03-1994 SHEET 1 OF 4

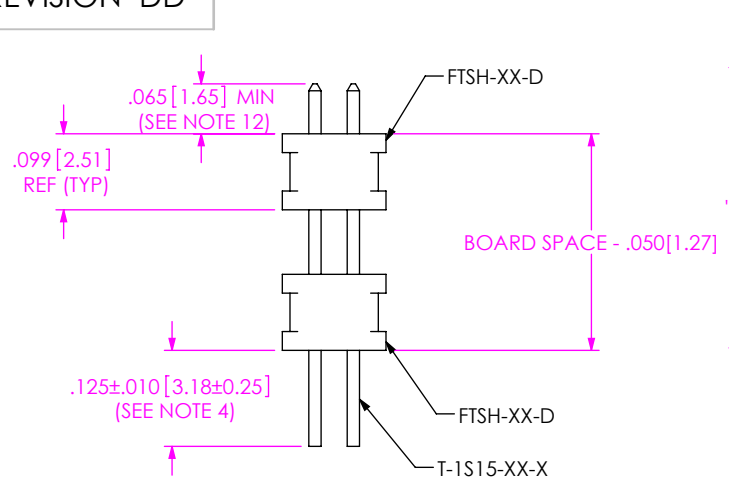

NOTE: SHEAR TAILS TO DIM SHOWN.

IN-PROCESS 1

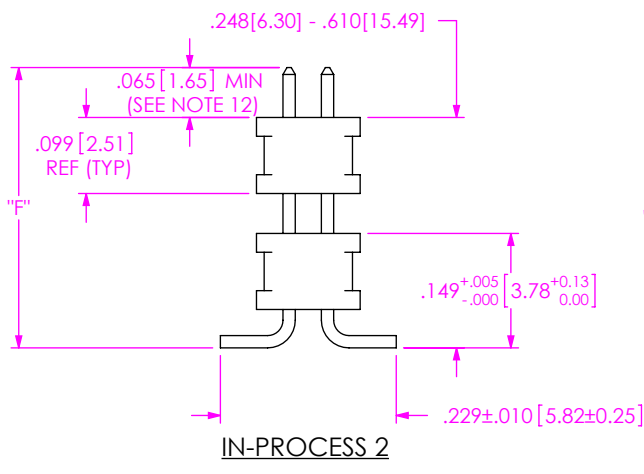
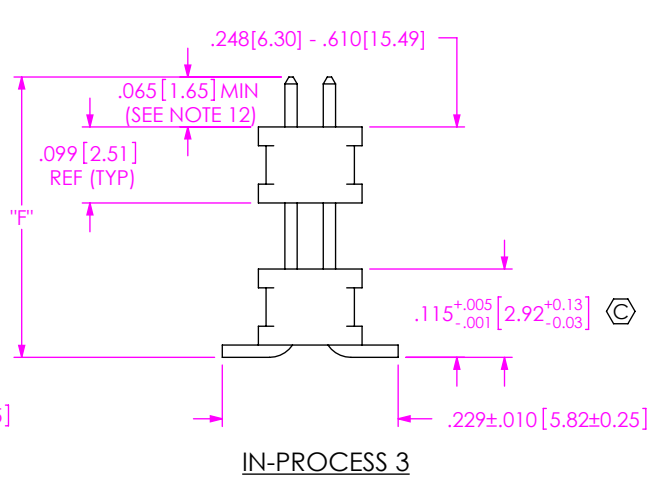

FIG 4

DIFFERENT AS SHOWN, OTHERWISE THE SAME AS FIG 1



IN-PROCESS 3

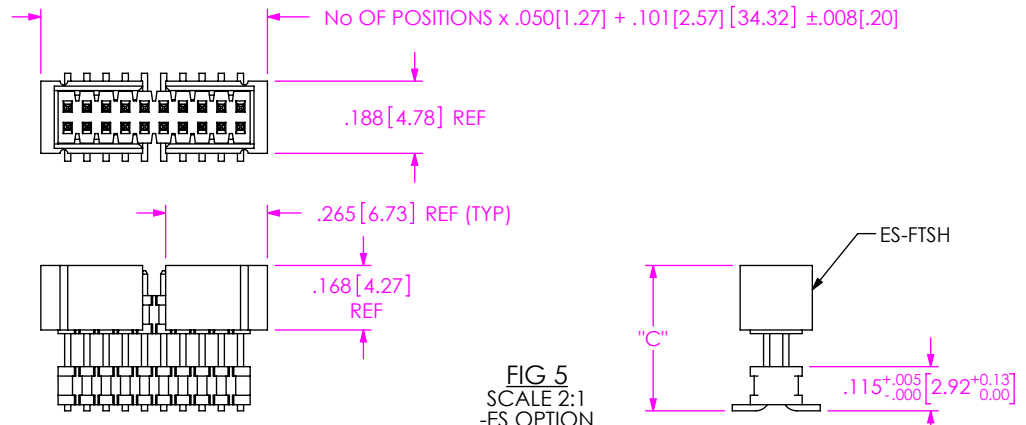

FIG 5  
SCALE 2:1  
-ES OPTION

DIFFERENT AS SHOWN, OTHERWISE THE SAME AS FIG 1  
9 POSITION MINIMUM (SEE NOTE 8)

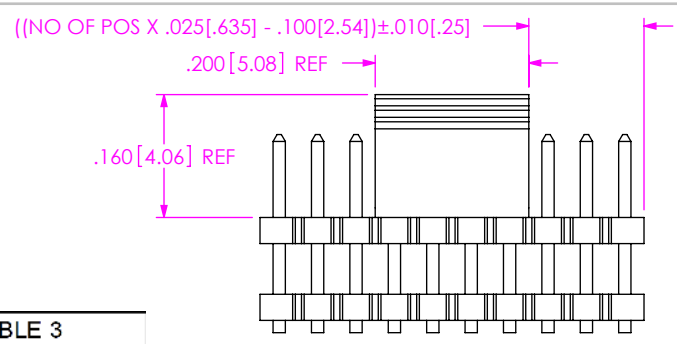
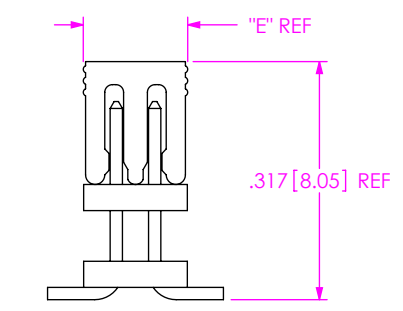

FIG 3  
(PICK AND PLACE PAD)  
(5 POSITION MINIMUM)



SHOWN WITH LEAD STYLE -03

TABLE 3	
PART No.	"E"
PPP-25	.130 [3.30]
PPP-25-NT	.230 [5.84]

**PROPRIETARY NOTE**  
THIS DOCUMENT CONTAINS CONFIDENTIAL AND PROPRIETARY INFORMATION AND ALL DESIGN, MANUFACTURING, REPRODUCTION, USE, PATENT RIGHTS AND SALES RIGHTS ARE EXPRESSLY RESERVED BY SAMTEC, INC. THIS DOCUMENT SHALL NOT BE DISCLOSED, IN WHOLE OR PART, TO ANY UNAUTHORIZED PERSON OR ENTITY NOR REPRODUCED, TRANSFERRED OR INCORPORATED IN ANY OTHER PROJECT IN ANY MANNER WITHOUT THE EXPRESS WRITTEN CONSENT OF SAMTEC, INC.

DO NOT SCALE DRAWING  
SHEET SCALE: 4:1



DESCRIPTION:  
.050 x .050 SURFACE MOUNT BOARD SPACERS  
DWG. NO.  
**FW-XX-XX-XX-D-XXX-XXX-XX-X-XX**  
BY: BRATCHER 11-03-1994 SHEET 2 OF 4

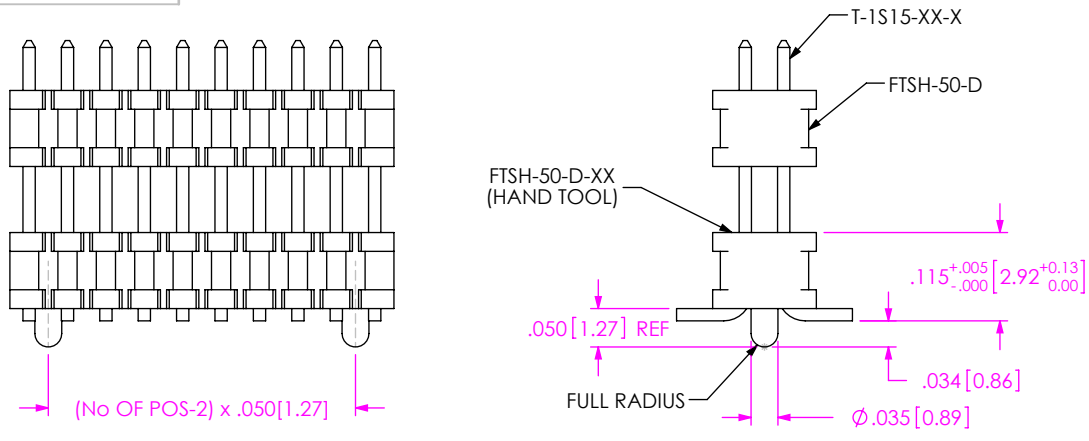

**FIG 7**  
-A OPTION (MOLDED)  
MOLD 3 POSITION MIN  
DIFFERENT AS SHOWN OTHERWISE SAME AS FIG 1

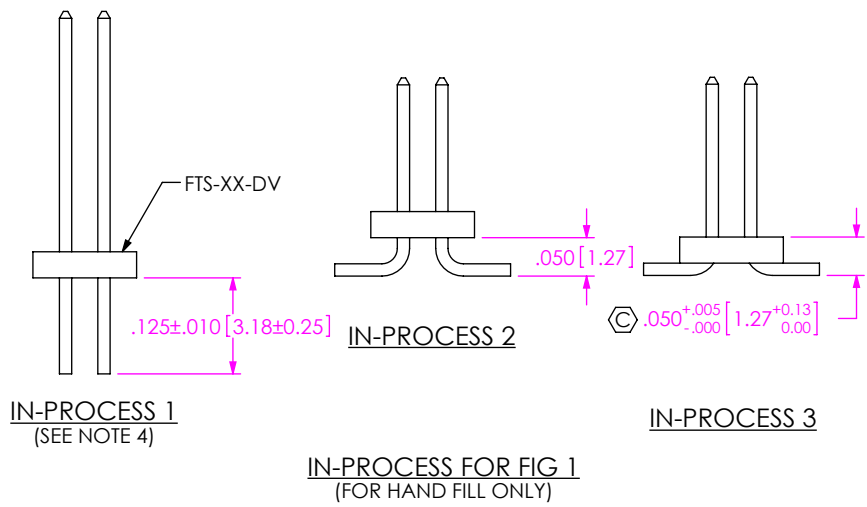

**IN-PROCESS FOR FIG 1**  
(FOR HAND FILL ONLY)

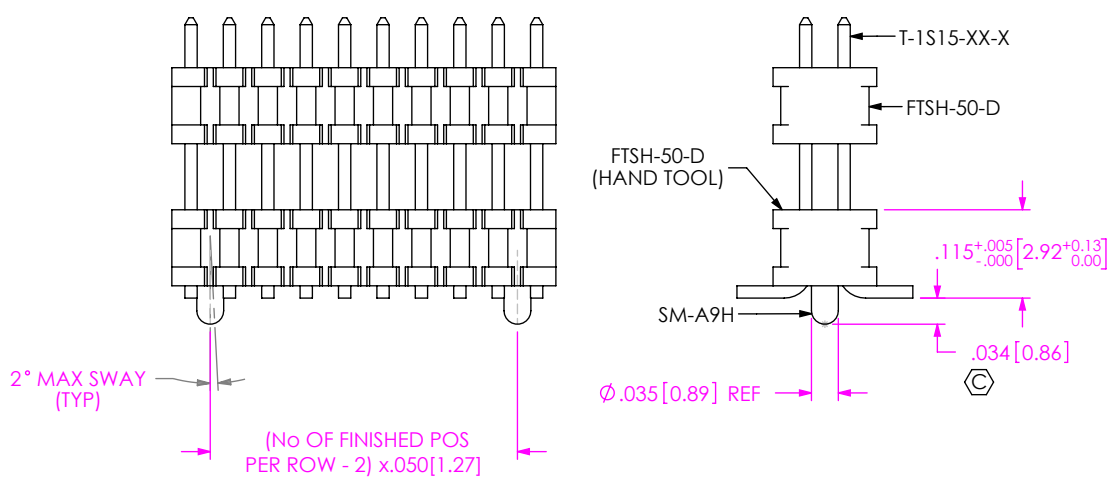

**FIG 8**  
-A OPTION (STAKED)  
6 POSITION MIN  
DIFFERENT AS SHOWN OTHERWISE SAME AS FIG 1

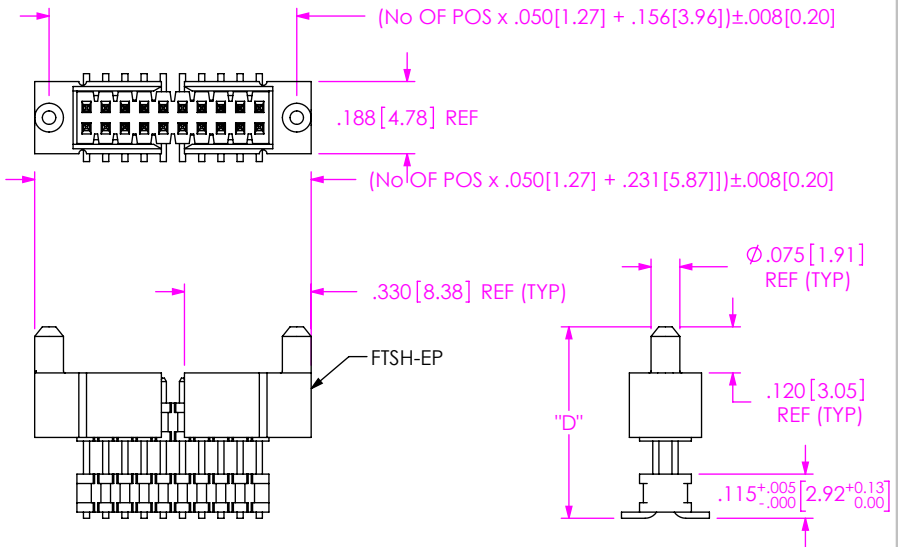
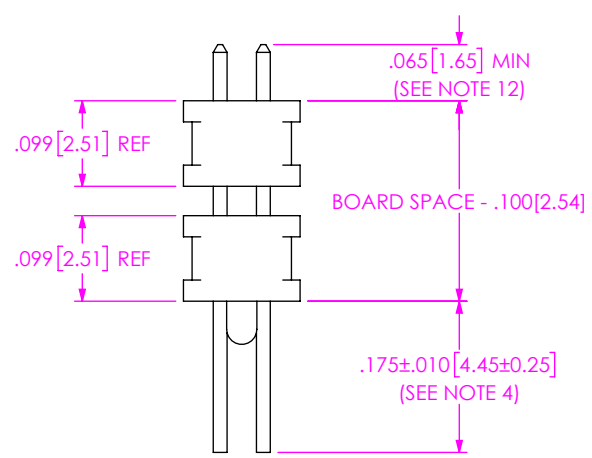

**FIG 6**  
-EP OPTION  
USE ONLY WHEN MATING TO CLP  
(9 POSITION MIN)  
(SEE NOTE 8)  
DIFFERENT AS SHOWN, OTHERWISE SAME AS FIG 1

**PROPRIETARY NOTE**  
THIS DOCUMENT CONTAINS CONFIDENTIAL AND PROPRIETARY INFORMATION AND ALL DESIGN, MANUFACTURING, REPRODUCTION, USE, PATENT RIGHTS AND SALES RIGHTS ARE EXPRESSLY RESERVED BY SAMTEC, INC. THIS DOCUMENT SHALL NOT BE DISCLOSED, IN WHOLE OR PART, TO ANY UNAUTHORIZED PERSON OR ENTITY NOR REPRODUCED, TRANSFERRED OR INCORPORATED IN ANY OTHER PROJECT IN ANY MANNER WITHOUT THE EXPRESS WRITTEN CONSENT OF SAMTEC, INC.  
  
DO NOT SCALE DRAWING  
  
SHEET SCALE: 4:1

**samtec**  
520 PARK EAST BLVD. NEW ALBANY, IN 47150  
PHONE: 812-944-6733 FAX: 812-948-5047  
e-Mail info@SAMTEC.com code 55322

DESCRIPTION:  
.050 x .050 SURFACE MOUNT BOARD SPACERS  
DWG. NO.  
**FW-XX-XX-XX-D-XXX-XXX-XX-X-XX**  
BY: BRATCHER 11-03-1994 SHEET 3 OF 4



IN-PROCESS 1  
SHEAR TAILS TO DIM SHOWN

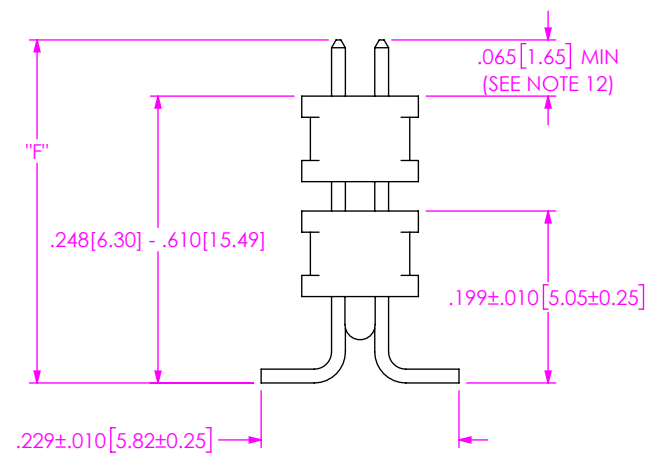

IN-PROCESS 2

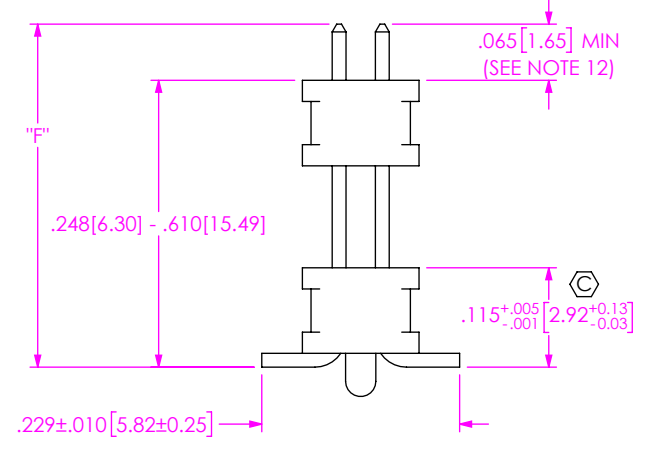

IN-PROCESS 3

IN-PROCESS FOR -A OPTION  
(FOR HAND FILL ONLY)

**PROPRIETARY NOTE**  
THIS DOCUMENT CONTAINS CONFIDENTIAL AND PROPRIETARY INFORMATION AND ALL DESIGN, MANUFACTURING, REPRODUCTION, USE, PATENT RIGHTS AND SALES RIGHTS ARE EXPRESSLY RESERVED BY SAMTEC, INC. THIS DOCUMENT SHALL NOT BE DISCLOSED, IN WHOLE OR PART, TO ANY UNAUTHORIZED PERSON OR ENTITY NOR REPRODUCED, TRANSFERRED OR INCORPORATED IN ANY OTHER PROJECT IN ANY MANNER WITHOUT THE EXPRESS WRITTEN CONSENT OF SAMTEC, INC.

DO NOT SCALE DRAWING

SHEET SCALE: 4:1



520 PARK EAST BLVD, NEW ALBANY, IN 47150  
PHONE: 812-944-6733 FAX: 812-948-5047  
e-Mail info@SAMTEC.com code 55322

DESCRIPTION:  
.050 x .050 SURFACE MOUNT BOARD SPACERS

DWG. NO.  
FW-XX-XX-XX-D-XXX-XXX-XX-X-XX

BY: BRATCHER 11-03-1994 SHEET 4 OF 4