

SECTION "A-A"
TERMINAL ORIENTATION

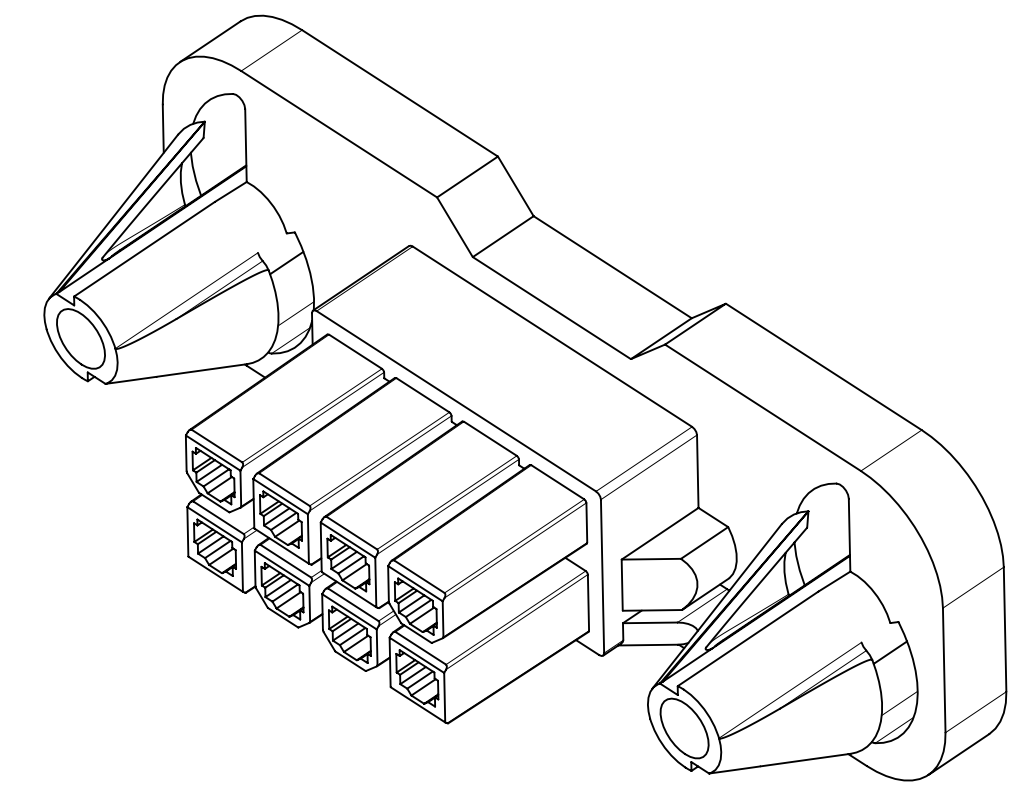

VIEW FOR 2 AND 4 CIRCUIT
NOTCH REMOVED

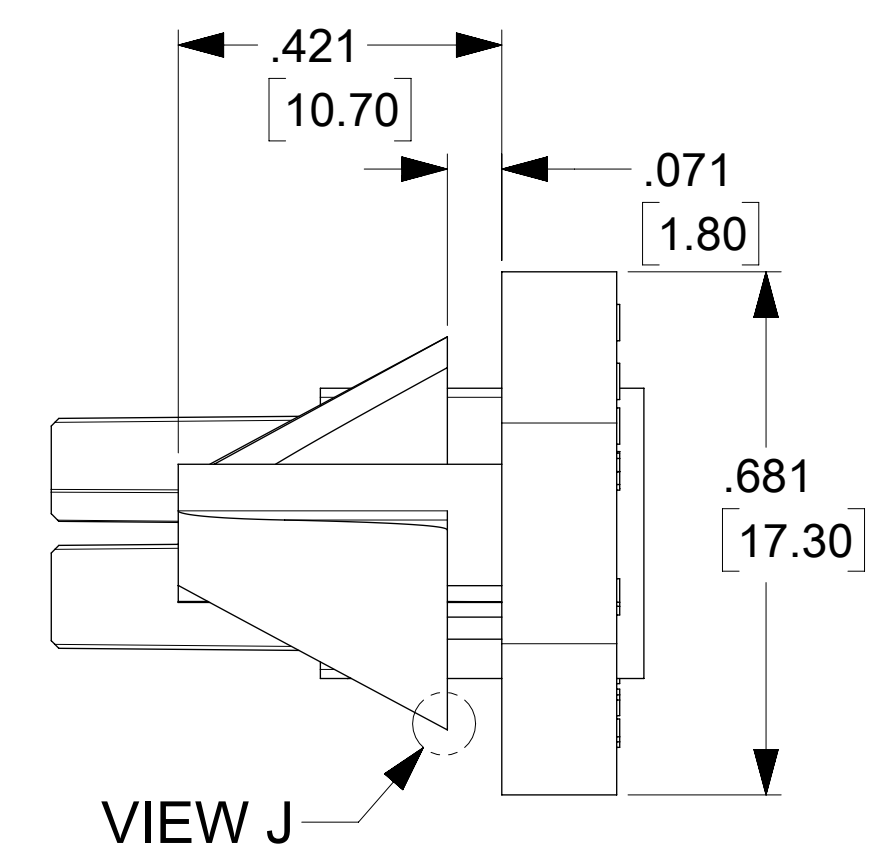
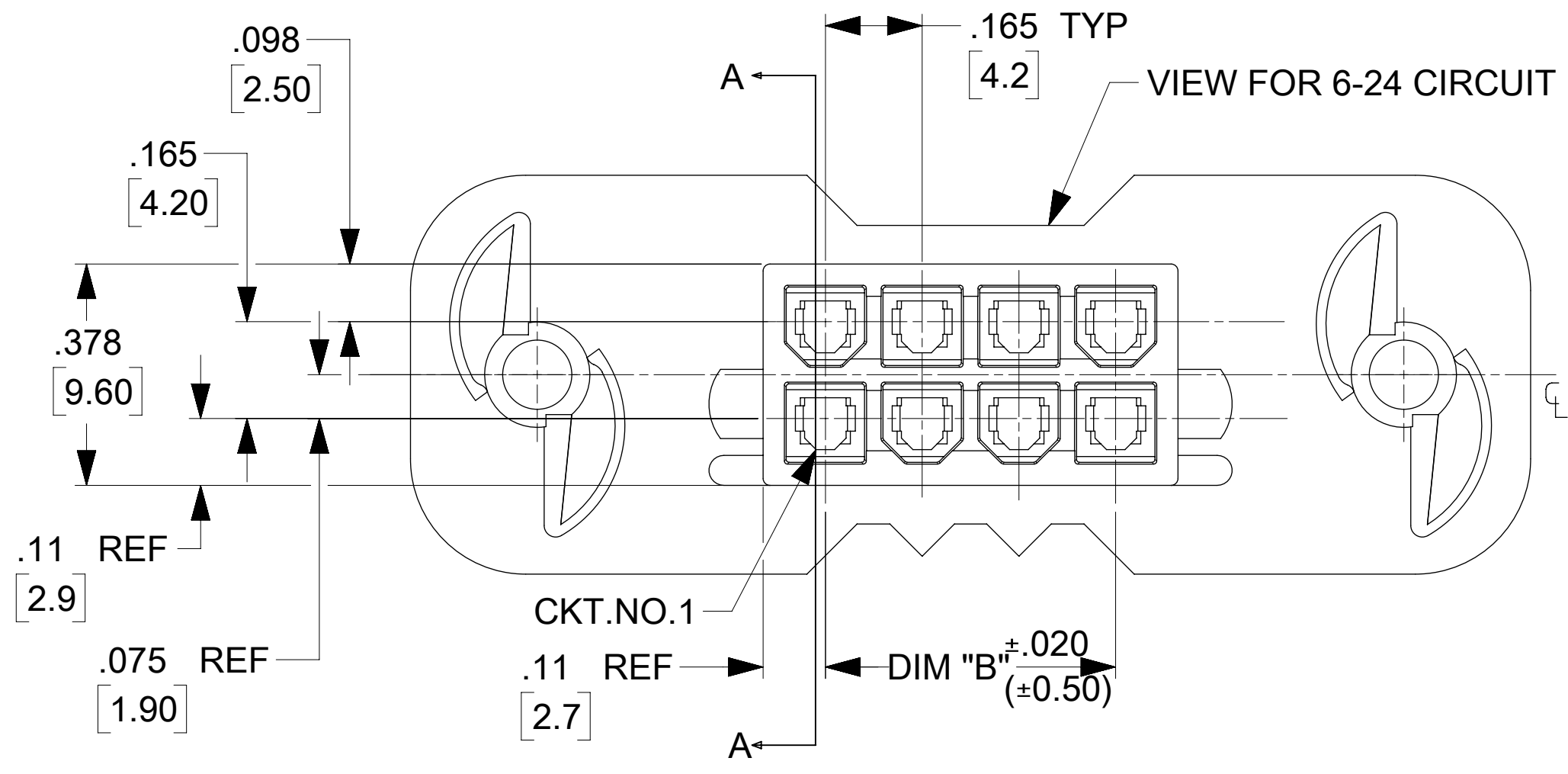
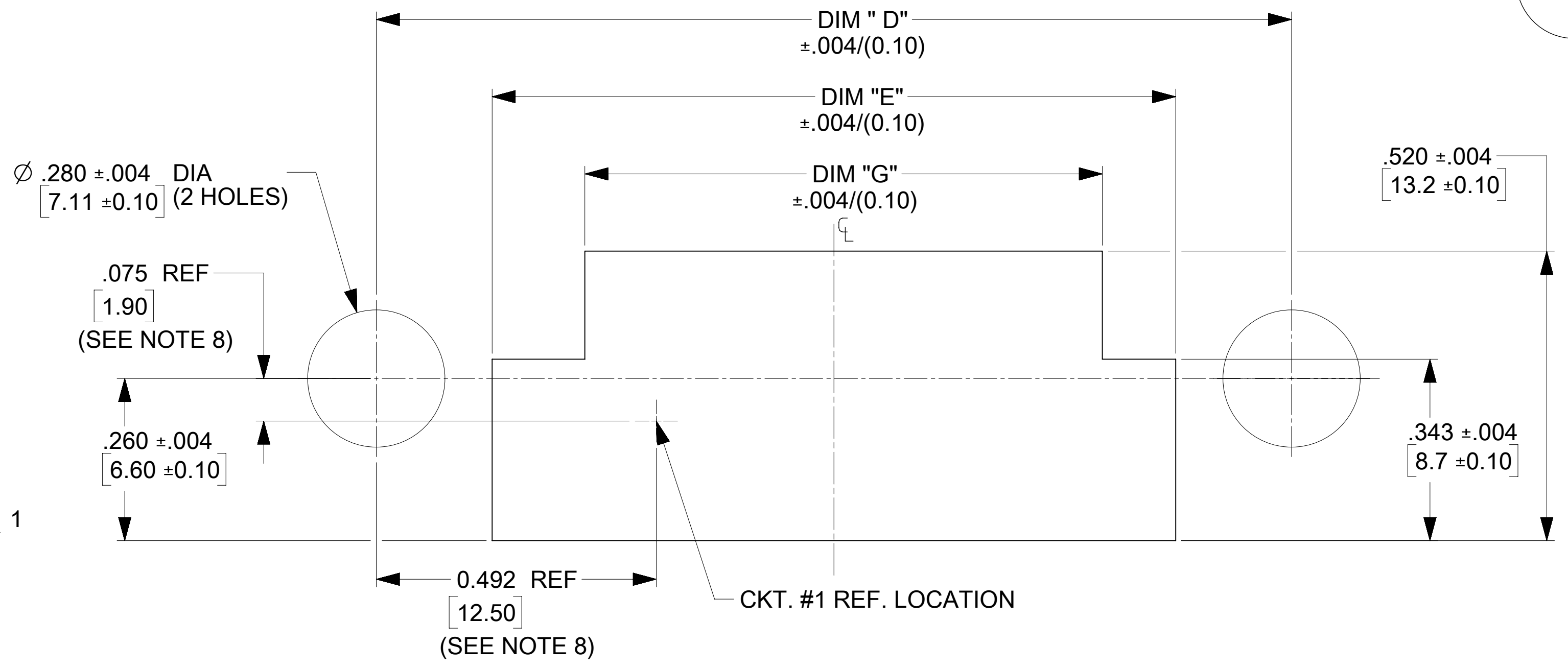
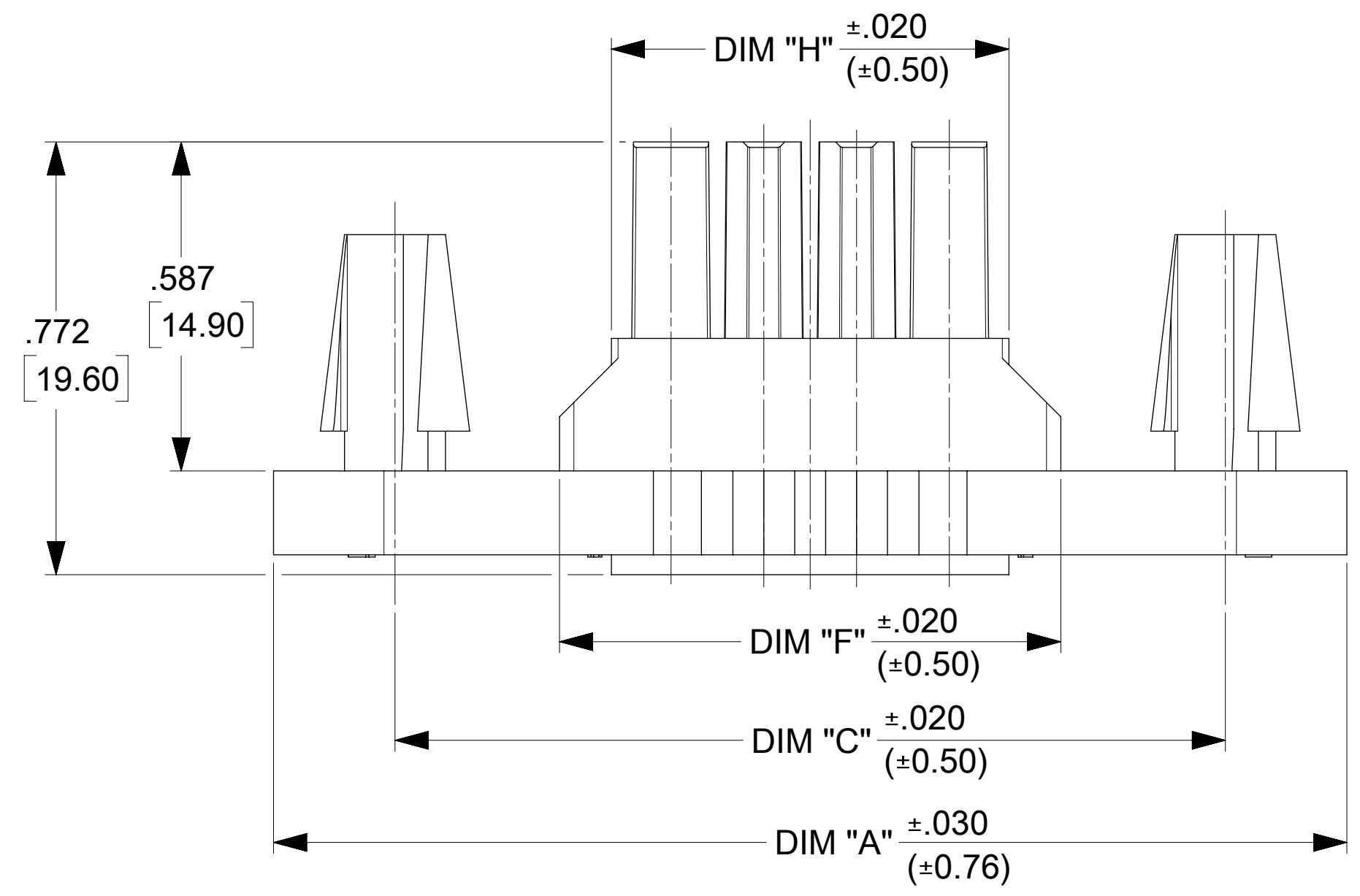
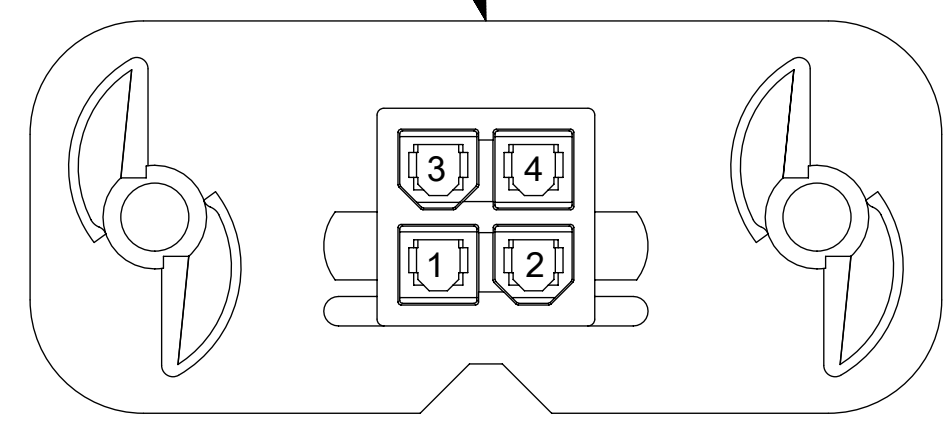

RECOMMENDED PANEL CUT-OUT FOR .050 \pm 0.12/(1.27 \pm 0.30) THICK PANEL
(SEE NOTE 11)

LEGEND:

42474 - * * * 1

BASE NUMBER

CIRCUIT SIZE (02-24)

MATERIAL (SEE NOTE 1)

CKT SIZE	DIM "A"	DIM "B"	DIM "C"	DIM "D"	DIM "E"	DIM "F"	DIM "G"	DIM "H"
2	1.417 (36.00)	N/A	.984 (25.00)	.984 (25.00)	.528 (13.40)	.398 (10.10)	.343 (8.70)	.213 (5.40)
4	1.583 (40.20)	.165 (4.20)	1.150 (29.20)	1.150 (29.20)	.693 (17.60)	.563 (14.30)	.508 (12.90)	.378 (9.60)
6	1.748 (44.40)	.331 (8.40)	1.315 (33.40)	1.315 (33.40)	.858 (21.80)	.728 (18.50)	.673 (17.10)	.543 (13.80)
8	1.913 (48.60)	.496 (12.60)	1.480 (37.60)	1.480 (37.60)	1.024 (26.00)	.894 (22.70)	.839 (21.30)	.709 (18.00)
10	2.078 (52.80)	.661 (16.80)	1.645 (41.80)	1.645 (41.80)	1.189 (30.20)	1.059 (26.90)	1.004 (25.50)	.874 (22.20)
12	2.244 (57.00)	.827 (21.00)	1.811 (46.00)	1.811 (46.00)	1.354 (34.40)	1.224 (31.10)	1.169 (29.70)	1.039 (26.40)
14	2.409 (61.20)	.992 (25.20)	1.976 (50.20)	1.976 (50.20)	1.520 (38.60)	1.390 (35.30)	1.335 (33.90)	1.205 (30.60)
16	2.575 (65.40)	1.157 (29.40)	2.172 (54.40)	2.172 (54.40)	1.685 (42.80)	1.555 (39.50)	1.500 (38.10)	1.370 (34.80)
18	2.740 (69.60)	1.323 (33.60)	2.307 (58.60)	2.307 (58.60)	1.850 (47.00)	1.720 (43.70)	1.665 (42.30)	1.535 (39.00)
20	2.906 (73.80)	1.488 (37.80)	2.472 (62.80)	2.472 (62.80)	2.016 (51.20)	1.886 (47.90)	1.831 (46.50)	1.701 (43.20)
22	3.071 (78.00)	1.653 (42.00)	2.638 (67.00)	2.638 (67.00)	2.181 (55.40)	2.051 (52.10)	1.996 (50.70)	1.866 (47.40)
24	3.236 (82.20)	1.819 (46.20)	2.803 (71.20)	2.803 (71.20)	2.346 (59.60)	2.217 (56.30)	2.161 (54.90)	2.031 (51.60)

- NOTES:**
- MATERIAL:
 "1" = NYLON 6/6, UNFILLED 94V-2, COLOR: NATURAL (WHITE)
 "2" = NYLON 6/6, UNFILLED 94V-0, COLOR: NATURAL (WHITE)
 "3" = NYLON 6/6, UNFILLED 94V-2, COLOR: BLACK
 "4" = NYLON 6/6, UNFILLED 94V-0, COLOR: BLACK
 "7" = NYLON 6/6, UNFILLED 94V-0, GLOW WIRE, COLOR: BLACK
 - FINISH: NOT APPLICABLE
 - PRODUCT SPECIFICATIONS: PS-5556-002
 - PACKAGING: PK-42474-001.
 - PART MATES WITH MINI-FIT B.M.I PLUG #42475, AND HEADERS 42404, 42440, 43810, 44068 & 43879.
 - PART TO BE USED WITH MOLEX FEMALE TERMINAL #5556.
 - THIS CONNECTOR ALLOWS FOR 050/(1.27) MAX. MISALIGNMENT IN ANY DIRECTION.
 - THIS DIMENSION TO BE USED FOR ALIGNMENT OF THE MATING CONNECTOR.
 - CONNECTOR ASSEMBLIES ARE NOT TO BE MATED OR UNMATED WHILE CIRCUITS ARE LIVE.
 - THIS PART IS INTENDED FOR ONE PANEL INSERTION ONLY. REMOVAL AND RE-INSERTION CAN DAMAGE THE MOUNTING SPIRALS.
 - PANEL SHOULD BE PUNCHED IN THE DIRECTION OF CONNECTOR INSERTION.
 - BOTH SPIRALS SHOULD BE INSERTED INTO THE PANEL AT THE SAME TIME. ROCKING THE PART INTO PLACE MAY CAUSE SPIRAL DAMAGE.
 - THIS PART IS NOT INTENDED TO PROVIDE ANY ALIGNMENT OF CUSTOMER COMPONENTS OR MODULES, SUCH AS POWER SUPPLIES AND CHASSIS.
 - IF THIS PRODUCT IS STORED IN AN ENVIRONMENT WITH A RELATIVE HUMIDITY OF LESS THAN 50%, MOISTURE MUST BE ADDED.
REFER TO TECHNICAL ADVISORY AS-45499-001 FOR INSTRUCTIONS.
 - A MAXIMUM TOLERANCE OF .050/(1.27) ALLOWS FOR 2 POINTS OF ELECTRICAL CONTACT. A MAXIMUM TOLERANCE OF .020/(.51) ALLOWS FOR 4 POINTS OF CONTACT.
 - WIRES ARE TO BE DRESSED IN SUCH A MANNER TO ALLOW THE TERMINALS TO FLOAT FREELY IN THE POCKET.
 - PART CONFORMS TO CLASS "B" REQUIREMENTS OF COSMETIC SPECIFICATION PS-45499-002.

FUNCTIONAL SYMBOLS	THIS DRAWING CONTAINS INFORMATION THAT IS PROPRIETARY TO MOLEX ELECTRONIC TECHNOLOGIES, LLC AND SHOULD NOT BE USED WITHOUT WRITTEN PERMISSION		CURRENT REV DESC:	
	DIMENSION UNITS	SCALE		
$\nabla_A = 0$	mm	1:1		
$\nabla_C = 0$	GENERAL TOLERANCES (UNLESS SPECIFIED)			
$\nabla_P = 0$		MM	INCH	
DIVISIONAL SYMBOLS	4 PLACES	\pm	\pm	
	3 PLACES	\pm	± 0.015	
	2 PLACES	\pm	0.38	
	1 PLACE	\pm	\pm	
0 PLACES	\pm	\pm		
	ANGULAR TOL	$\pm 0.5^\circ$		
DRAFT WHERE APPLICABLE MUST REMAIN WITHIN DIMENSIONS		THIRD ANGLE PROJECTION	DRAWING	SERIES
			D-SIZE	42474
DOCUMENT NUMBER		DOC TYPE	DOC PART	REVISION
SD-42474-XXXX		PSD	001	P14
MATERIAL NUMBER		CUSTOMER		SHEET NUMBER
SEE SHEET 2		GENERAL MARKET		1 OF 2

PART NUMBER	ENG. NUMBER	CKT. SIZE	MATERIAL (SEE NOTE 1)
NOT TOLLED	42474-0211	2	94V-2
15-06-0040	42474-0411	4	94V-2
15-06-0060	42474-0611	6	94V-2
15-06-0080	42474-0811	8	94V-2
15-06-0100	42474-1011	10	94V-2
NOT TOLLED	42474-1211	12	94V-2
15-06-0140	42474-1411	14	94V-2
NOT TOLLED	42474-1611	16	94V-2
15-06-0180	42474-1811	18	94V-2
NOT TOLLED	42774-2011	20	94V-2
NOT TOLLED	42474-2211	22	94V-2
15-06-0240	42474-2411	24	94V-2

PART NUMBER	ENG. NUMBER	CKT. SIZE	MATERIAL (SEE NOTE 1)
NOT TOLLED	42474-0221	2	94V-0
15-06-0041	42474-0421	4	94V-0
15-06-0061	42474-0621	6	94V-0
15-06-0081	42474-0821	8	94V-0
15-06-0101	42474-1021	10	94V-0
NOT TOLLED	42474-1221	12	94V-0
15-06-0141	42474-1421	14	94V-0
NOT TOLLED	42474-1621	16	94V-0
15-06-0181	42474-1821	18	94V-0
NOT TOLLED	42774-2021	20	94V-0
NOT TOLLED	42474-2221	22	94V-0
15-06-0241	42474-2421	24	94V-0

ITEM NUMBER	CKT. SIZE	MATERIAL (SEE NOTE 1)
NOT TOLLED	2	94V-2
42474-0431	4	94V-2
42474-0631	6	94V-2
42474-0831	8	94V-2
42474-1031	10	94V-2
NOT TOLLED	12	94V-2
42474-1431	14	94V-2
NOT TOLLED	16	94V-2
42474-1831	18	94V-2
NOT TOLLED	20	94V-2
NOT TOLLED	22	94V-2
42474-2431	24	94V-2

ITEM NUMBER	CKT. SIZE	MATERIAL (SEE NOTE 1)
NOT TOLLED	2	94V-0
42474-0441	4	94V-0
42474-0641	6	94V-0
42474-0841	8	94V-0
42474-1041	10	94V-0
NOT TOLLED	12	94V-0
42474-1441	14	94V-0
NOT TOLLED	16	94V-0
42474-1841	18	94V-0
NOT TOLLED	20	94V-0
NOT TOLLED	22	94V-0
42474-2441	24	94V-0

ITEM NUMBER	CKT. SIZE	MATERIAL (SEE NOTE 1) GLOW WIRE
NOT TOLLED	2	94V-0,GLOW WIRE
NOT TOLLED	4	94V-0,GLOW WIRE
NOT TOLLED	6	94V-0,GLOW WIRE
NOT TOLLED	8	94V-0,GLOW WIRE
NOT TOLLED	10	94V-0,GLOW WIRE
NOT TOLLED	12	94V-0,GLOW WIRE
NOT TOLLED	14	94V-0,GLOW WIRE
NOT TOLLED	16	94V-0,GLOW WIRE
NOT TOLLED	18	94V-0,GLOW WIRE
NOT TOLLED	20	94V-0,GLOW WIRE
NOT TOLLED	22	94V-0,GLOW WIRE
NOT TOLLED	24	94V-0,GLOW WIRE

P13

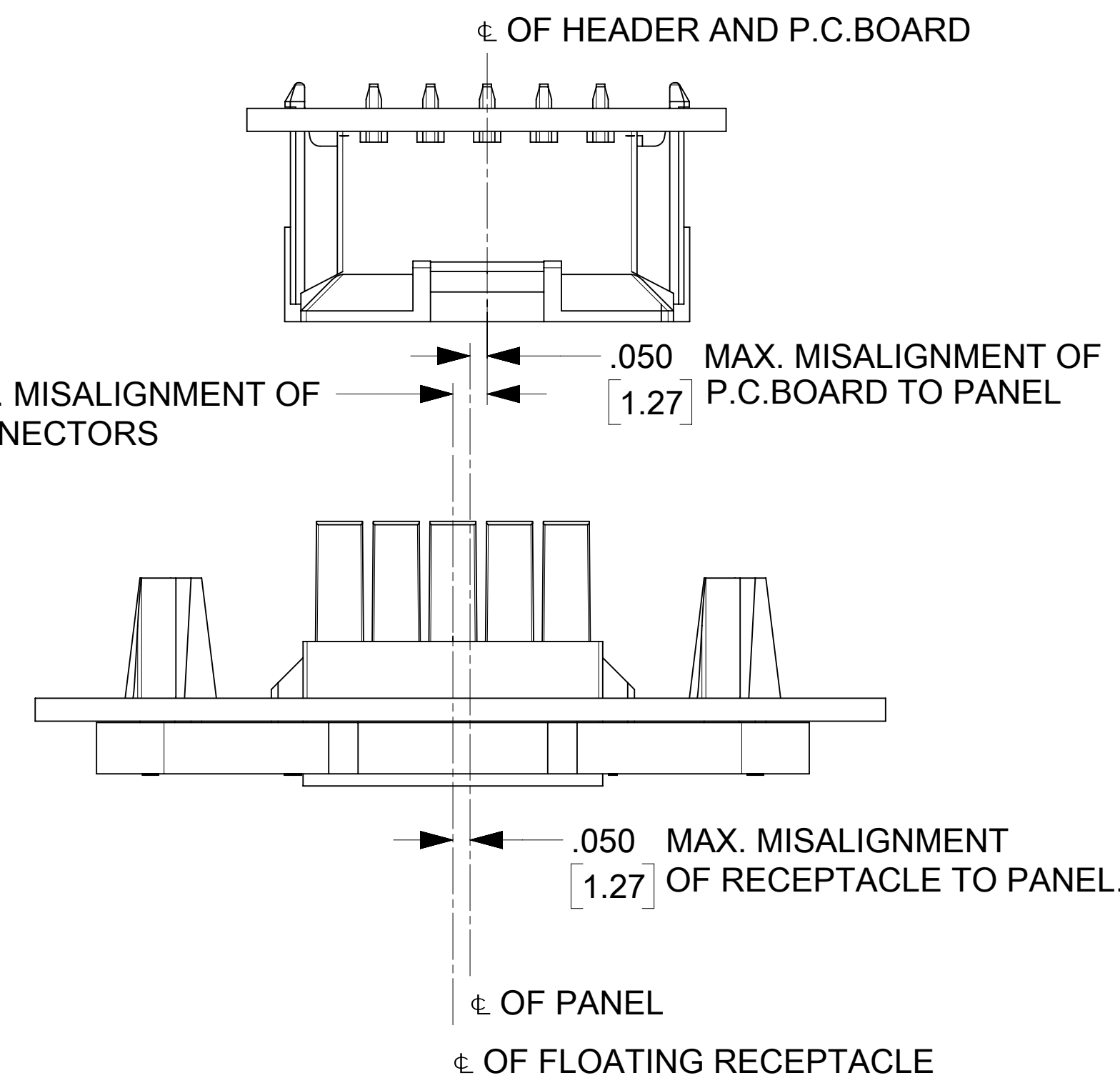
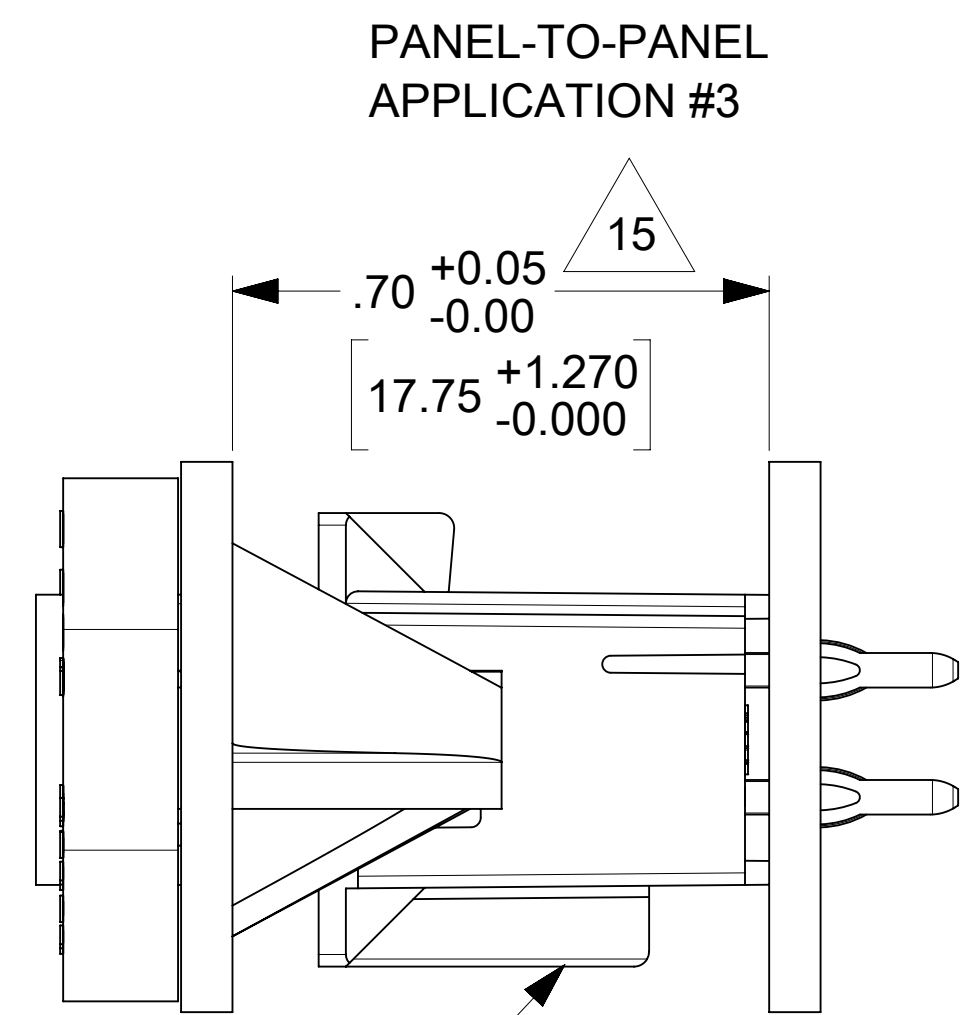
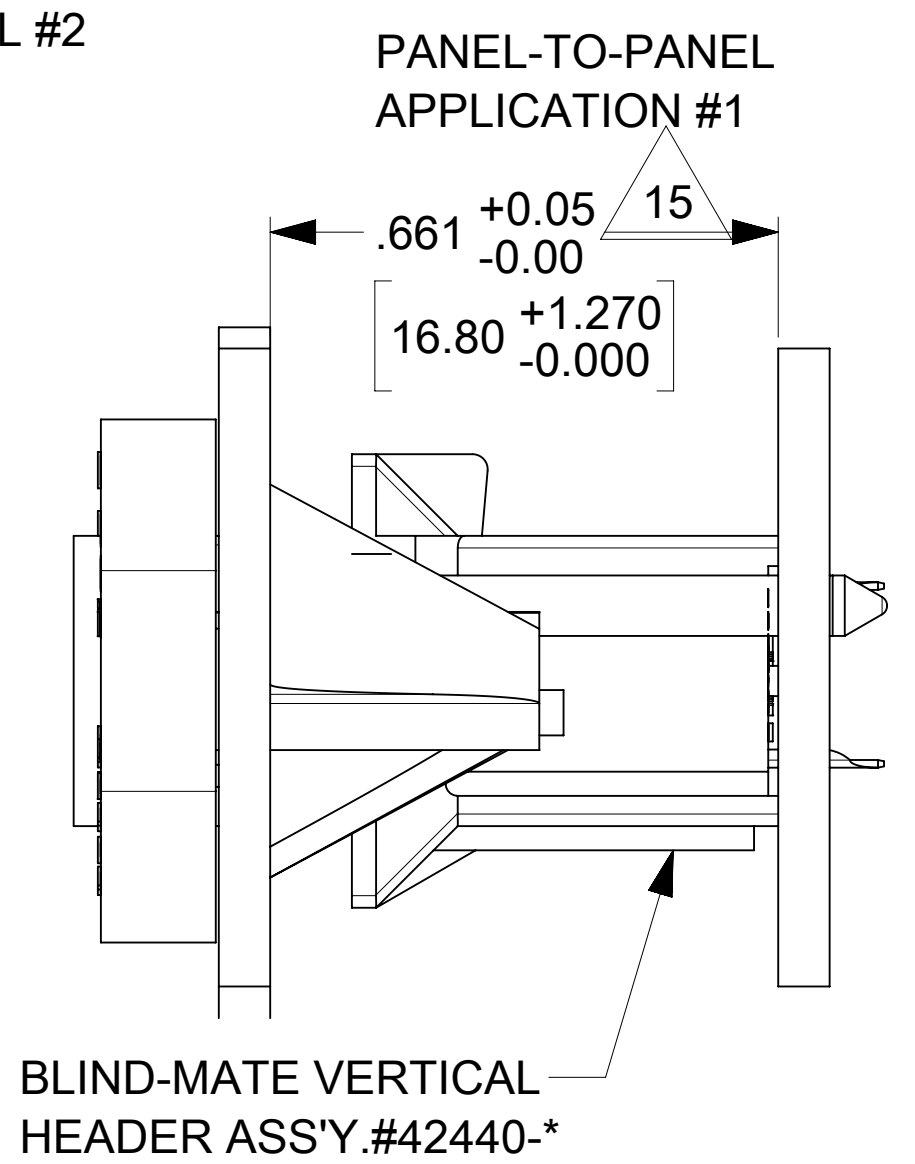
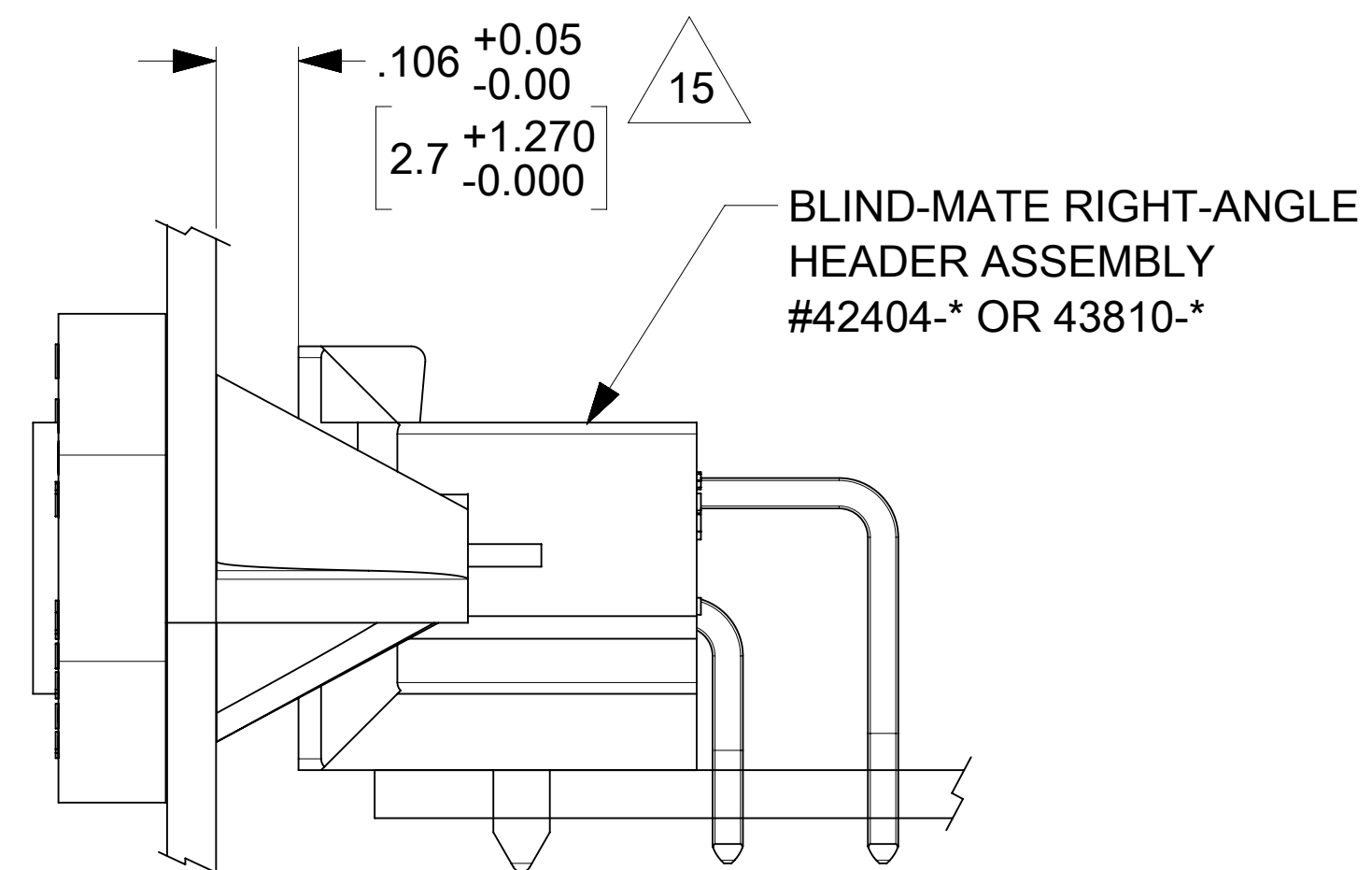
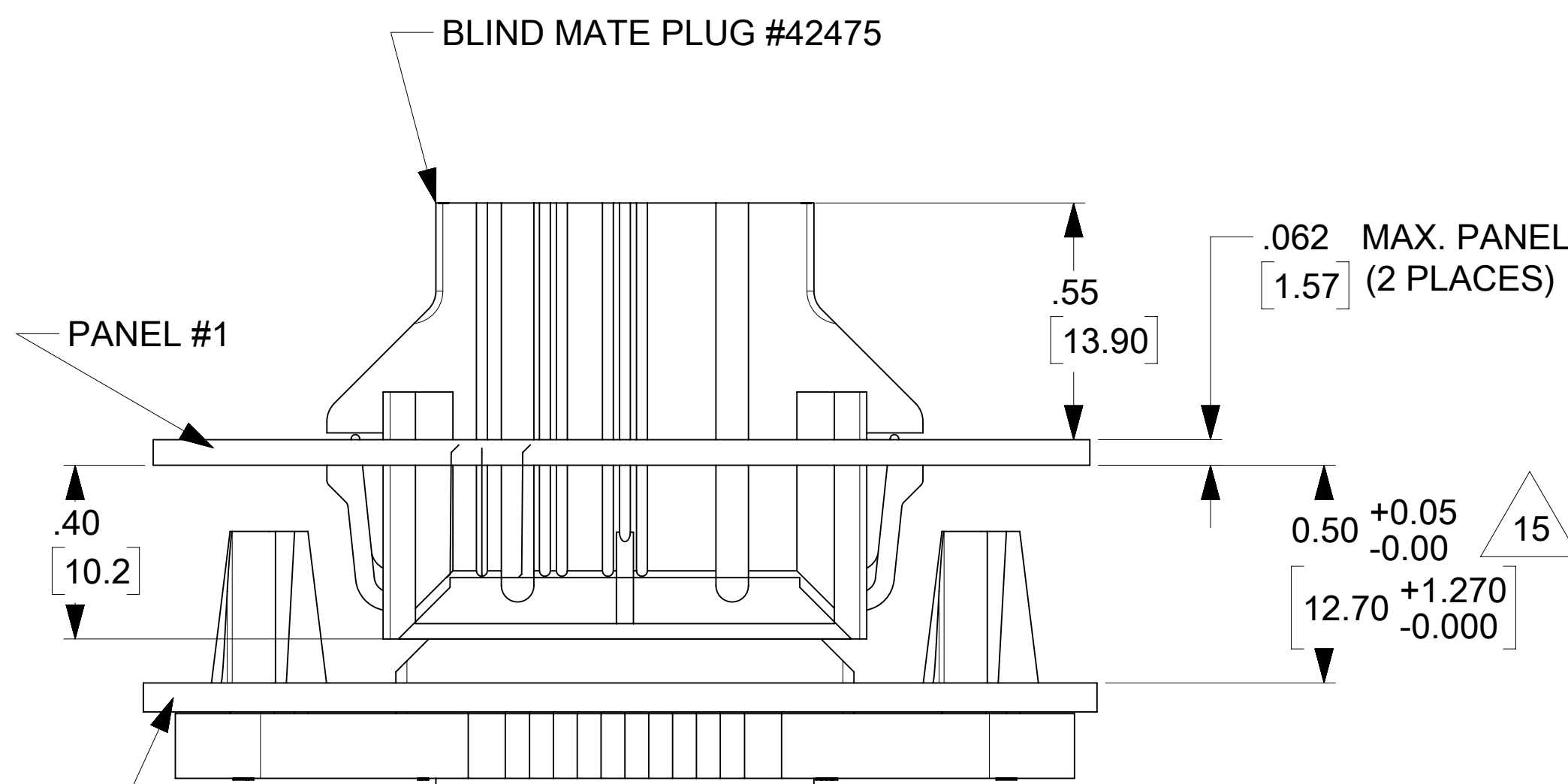

ALIGNMENT TOLERANCES FOR .050/1.27 MAX. BOARD-TO-PANEL MISALIGNMENT (+/- .050/1.27 RECEPTACLE FLOAT)

FUNCTIONAL SYMBOLS FA = 0 FC = 0 FE = 0 DIVISIONAL SYMBOLS	THIS DRAWING CONTAINS INFORMATION THAT IS PROPRIETARY TO MOLEX ELECTRONIC TECHNOLOGIES, LLC AND SHOULD NOT BE USED WITHOUT WRITTEN PERMISSION									
	DIMENSION UNITS: mm		SCALE: 1:1		CURRENT REV DESC:					
	GENERAL TOLERANCES (UNLESS SPECIFIED)									
	4 PLACES ±		MM		INCH		EC NO: 688090			
3 PLACES ±		±		± 0.015		DRWN: HPAN18 2021/12/08				
2 PLACES ±		0.38		±		CHK'D: XQZHANG 2021/12/28				
1 PLACE ±		±		±		APPR: XQZHANG 2021/12/28				
0 PLACES ±		±		±		INITIAL REVISION:				
ANGULAR TOL ± 0.5°		±		±		DRWN: GEP 1989/08/24				
DRAFT WHERE APPLICABLE MUST REMAIN WITHIN DIMENSIONS		THIRD ANGLE PROJECTION		DRAWING: D-SIZE		SERIES: 42474		MATERIAL NUMBER: SEE SHEET 2		CUSTOMER: GENERAL MARKET

**PANEL-MOUNT RECEPTACLE
BLIND MATE MINI-FIT JR. SERIES**

PRODUCT CUSTOMER DRAWING

DOCUMENT NUMBER	DOC TYPE	DOC PART	REVISION
SD-42474-XXXX	PSD	001	P14

SHEET NUMBER: 2 OF 2