

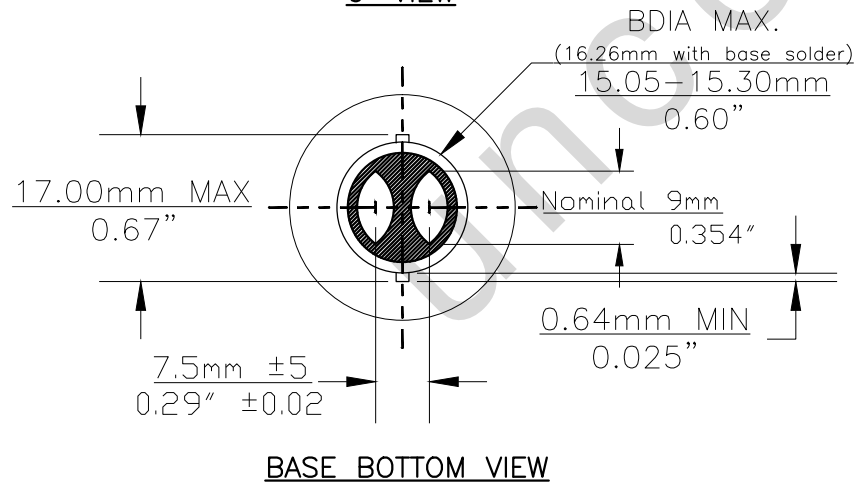

PART NO.	BASE TYPE	DESIGN VOLTS	DESIGN AMPS	MSCD	FILAMENT TYPE	AVERAGE LIFE HOURS
7528	D.C. INDEX BAY15d	13.5V 13.5V	1.85±6% 0.44±10%	35±15% 2.78±20%	C-6 C-6	160 1600

REVISIONS			
REV #	DESCRIPTION	DATE	APPROVED
1	ISSUED	10/12/2007	S.L.
2	UPDATED RoHS COMPLIANCE	01/29/2009	S.L.
3	ADDED VIEW	05/27/2014	R.M.
4	REVISED BDIA FROM 15.24mm	10/28/2019	R.M.

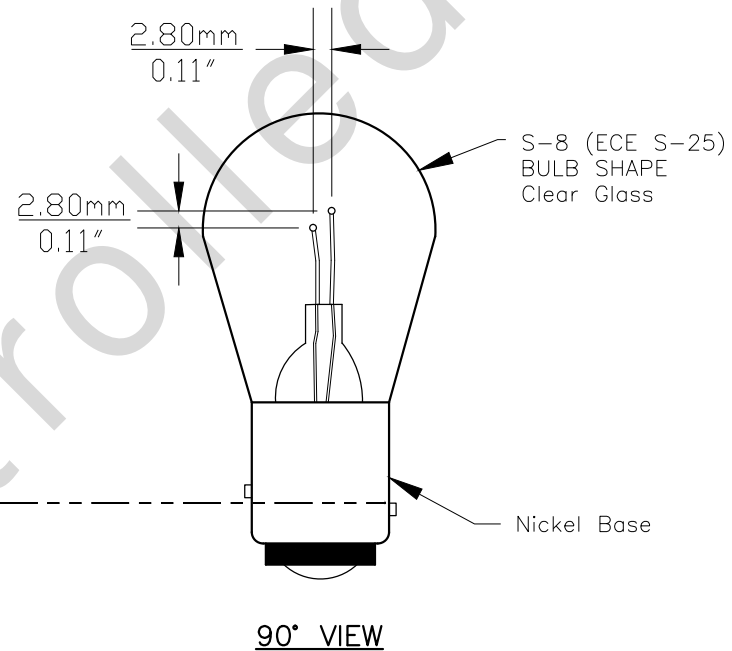
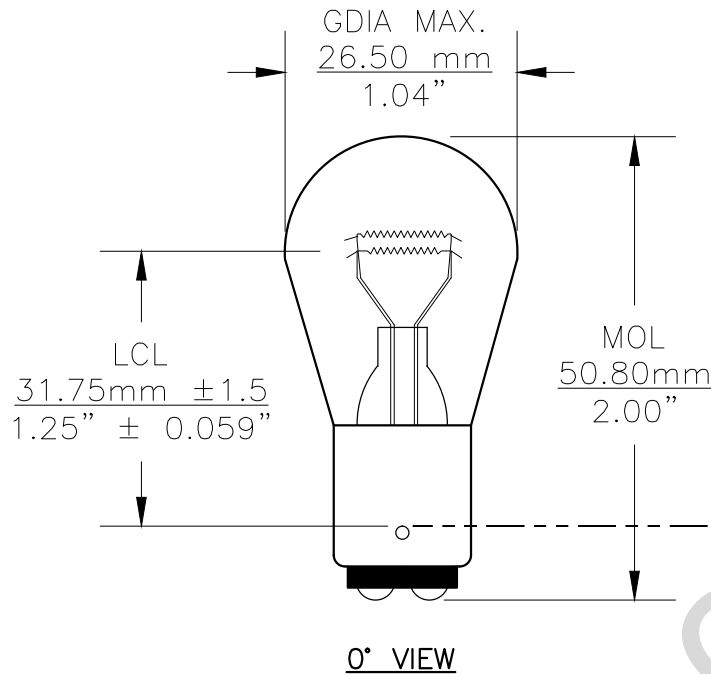

Note: Made according to ECE/R37 specifications

UNLESS OTHERWISE SPECIFIED: DIMENSIONS ARE IN INCHES TOLERANCES		CEC INDUSTRIES LTD	
DECIMALS .XX ± .05 .XXX ± .010 FRACTIONAL ±1/64	ANGULAR ± 0.5°	599 BOND STREET	LINCOLNSHIRE, IL 60069
DRAWN SIDNEY LIU	DATE 10/12/2007	TITLE LIGHT BULB NO. 7528 (P21W/5W-12V)	
CHECKED	SIZE A	FSCM NO.	DWG NO. 7528 REV 4
DESIGN	SCALE	PLOT SCALE	SHEET 1 OF 1
MATERIAL	FILE 7528.pdf	DRAWING NOT TO SCALE	