

## Features

Package	3216 Dome lens type, Water clear epoxy
Product features	<ul style="list-style-type: none"> <li>• Outer dimension 3.2 x 1.6 x 1.85mm ( L x W x H )</li> <li>• Surface mounting(-TR) / Reverse mounting(-RR) available</li> <li>• 16 times brighter than current product (TYP. brightness)</li> <li>• Lead-free soldering compatible</li> <li>• RoHS2 compliant</li> </ul>

## Recommended Applications

- Amusement equipment, Home appliances, OA/FA, other general applications

# Outline Dimensions

FKA1105W-TR/-RR

Unit : mm  
 Weight : 7.81mg  
 Tolerance : ±0.1

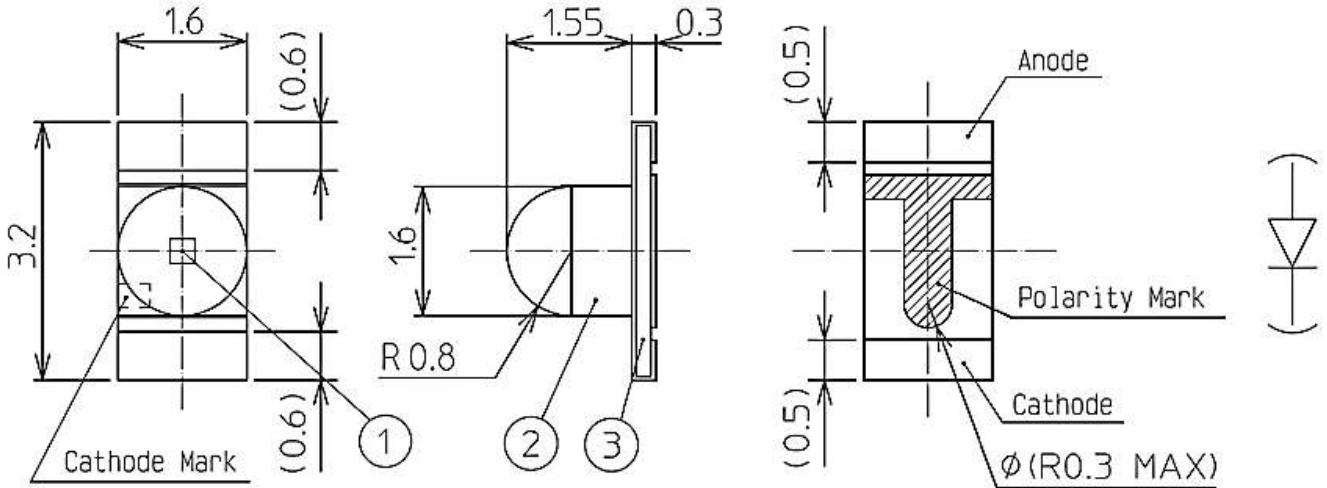

NO.	PART NAME	MATERIALS	QTY.
①	LED Die	AlGaInP	1
②	Plastic	Epoxy Resin	1
③	Substance	Glass Fabrics	1

# Recommended Pad

Unit : mm  
 Tolerance : ±0.1

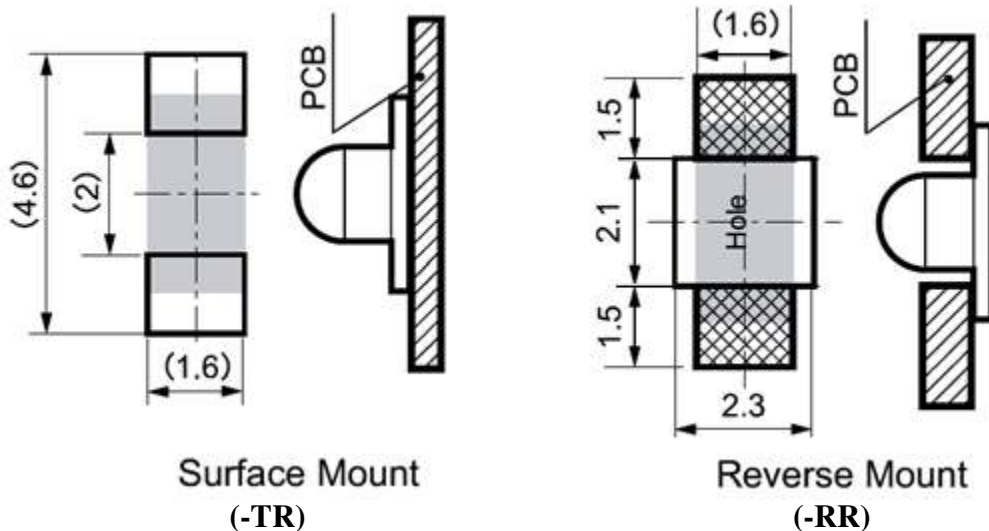

## 【 Product Overview 】

Die Material	AlGaInP
Emitting Color	Orange
Resin Color 【Emitting Area】	Water Clear

## 【 Absolute Maximum Ratings 】

(Ta=25°C)

ITEM	SYMBOL	MAXIMUM RATINGS	UNITS
Power Dissipation	Pd	81	mW
Forward Current	IF	30	mA
Repetitive Peak Forward Current "1ms, 1/20duty"	IFRM	100	mA
IF Derate Linearly from "75°C"	ΔIF	1.00	mA/°C
IFRM Derate Linearly from "75°C"	ΔIFRM	3.33	mA/ °C
Reverse Voltage	VR	5	V
Operating Temperature	Topr	-40 to +100	°C
Storage Temperature	Tstg	-40 to +105	°C
Soldering Temperature "Reflow Soldering"	Tsld	260	°C

Notes

Notes Please refer to Page 8, Soldering Conditions.

## 【 Electro and Optical Characteristics 】

(Ta=25°C)

ITEM	SYMBOL	CONDITIONS	MIN.	TYP.	MAX.	UNITS
Forward Voltage	VF	IF = 20mA	1.7	2.2	2.6	V
Reverse Current	IR	VR = 5V	-	-	100	μA
Luminous Intensity	Iv	IF = 20mA	1,500	-	6,800	mcd
Peak Wavelength	λp	IF = 20mA	-	610	-	nm
Dominant Wavelength	λd	IF = 20mA	597	-	612	nm
Spectral Line Half Width	Δλ	IF = 20mA	-	15	-	nm

Above Luminous Intensity (Iv) values and Dominant Wavelength (λd) values are the setup value of the selection machine. 【Tolerance : Iv...±10%, λd...±1nm】

## 【 Sorting For Luminous Intensity and Dominant Wavelength 】

LEDs shall be sorted out into the following ranks of Luminous Intensity and Dominant Wavelength.

Luminous Intensity (Iv) Rank

Rank	Iv(mcd)		CONDITIONS
	MIN.	MAX	
DB	1,500	2,200	I <sub>F</sub> =20mA T <sub>a</sub> =25°C
DC	2,200	3,300	
DD	3,300	4,700	
DE	4,700	6,800	

Dominant Wavelength (λd) Rank

Rank	λd (nm)		CONDITIONS
	MIN.	MAX.	
A	597	600	I <sub>F</sub> =20mA T <sub>a</sub> =25°C
B	600	603	
C	603	606	
D	606	609	
E	609	612	

Notes Above Luminous Intensity (Iv) values and Dominant Wavelength (λd) values are the setup value of the selection machine.

【Tolerance : Iv... ± 10%, λd... ± 1nm】

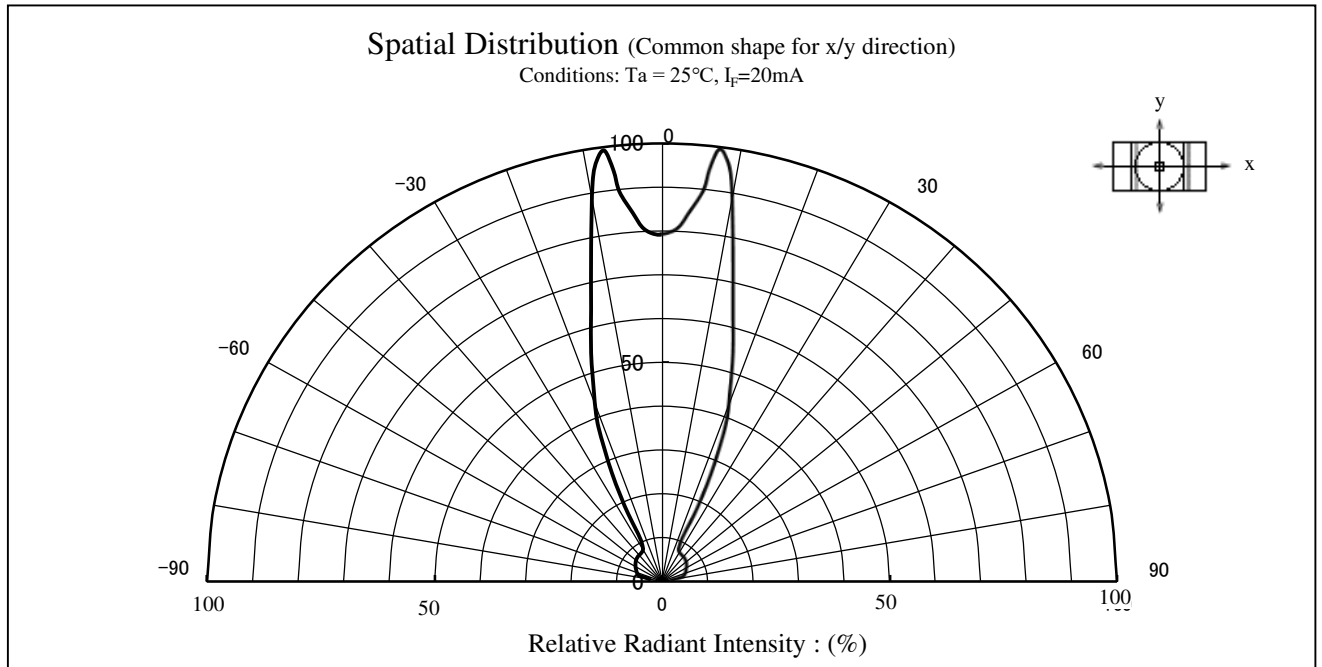
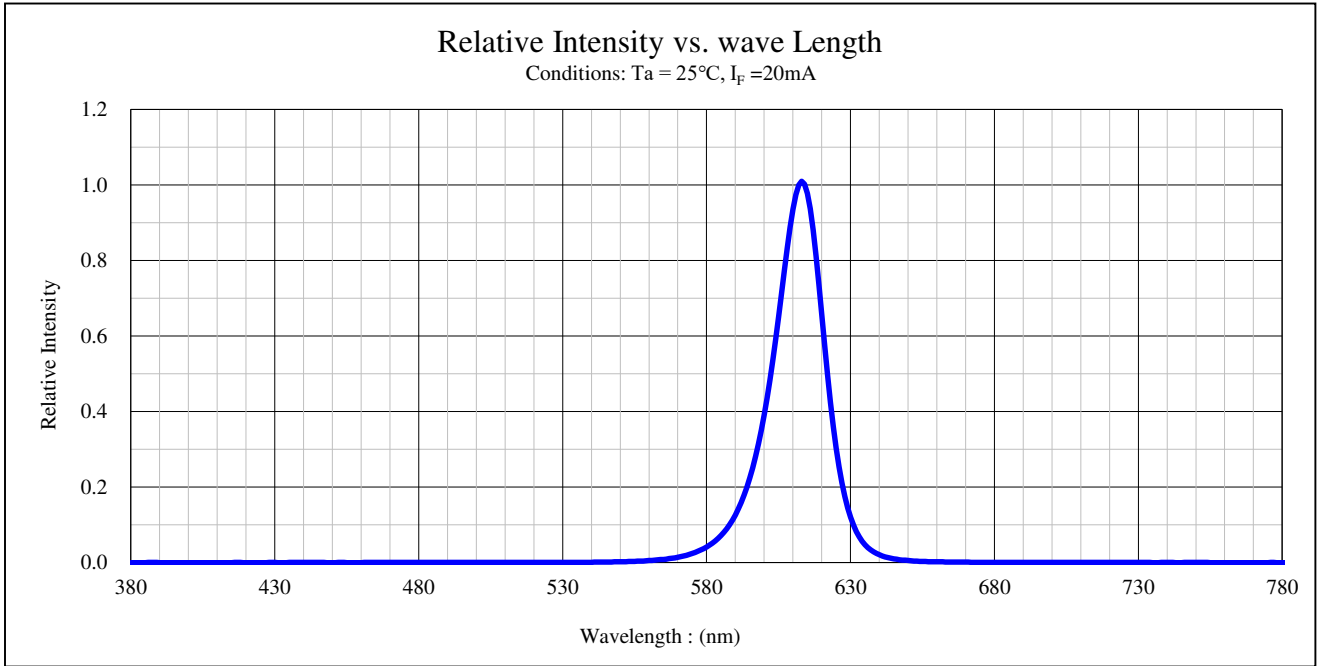

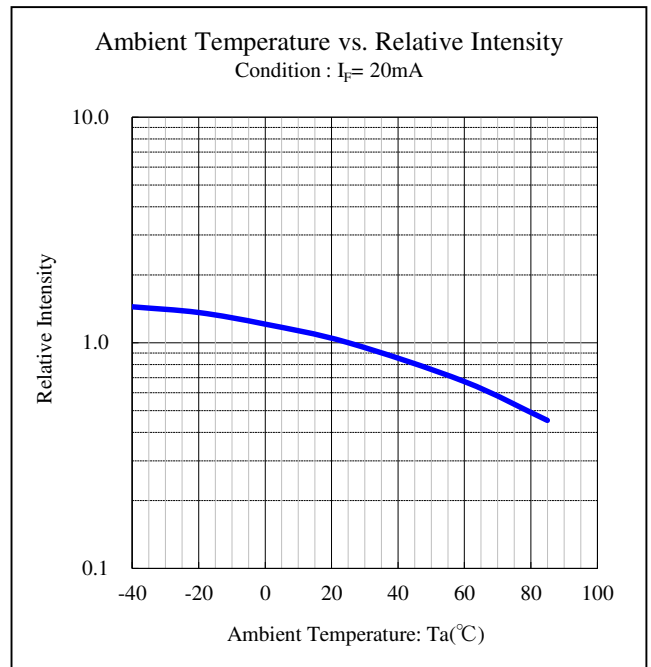
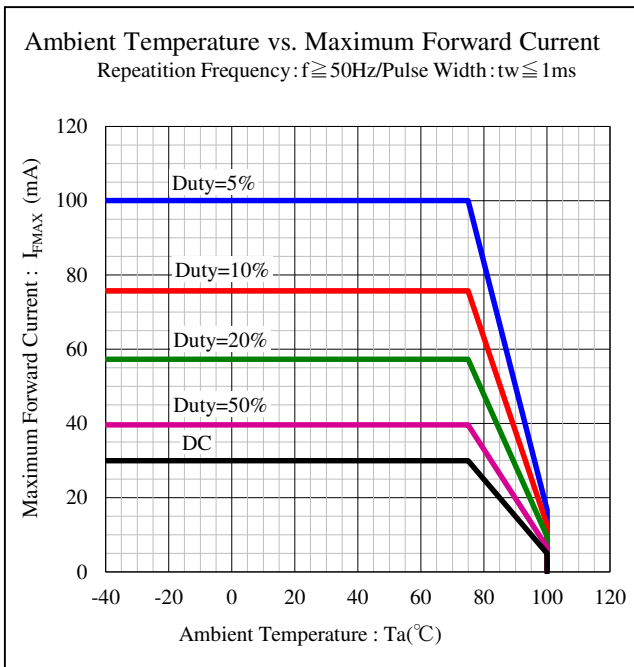
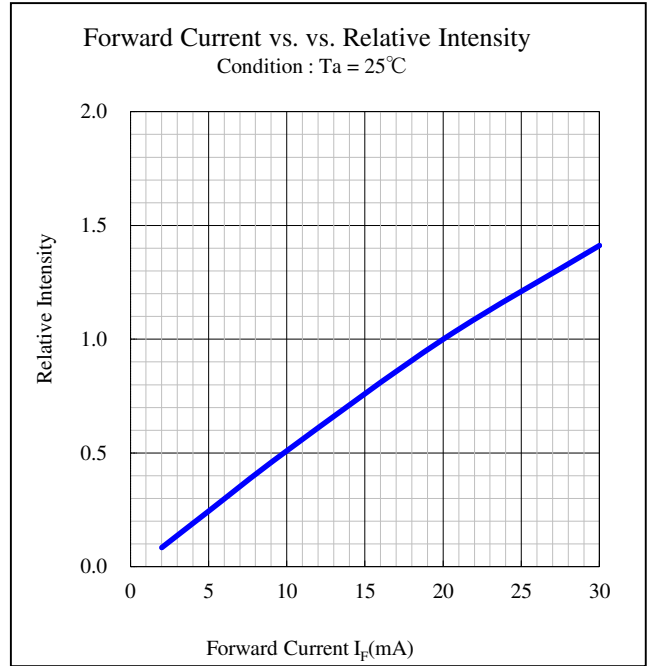
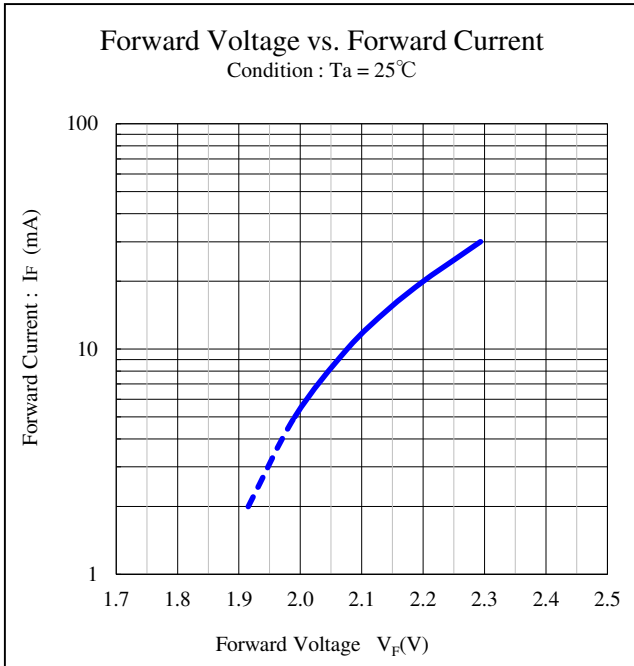

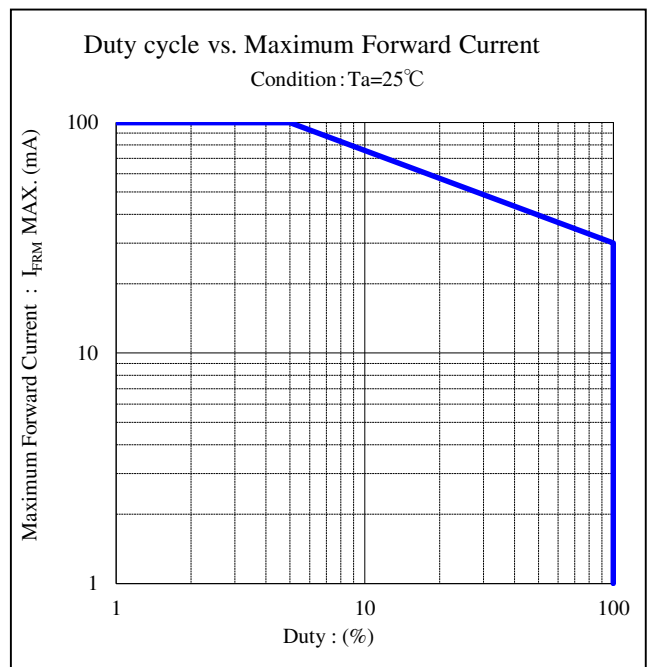
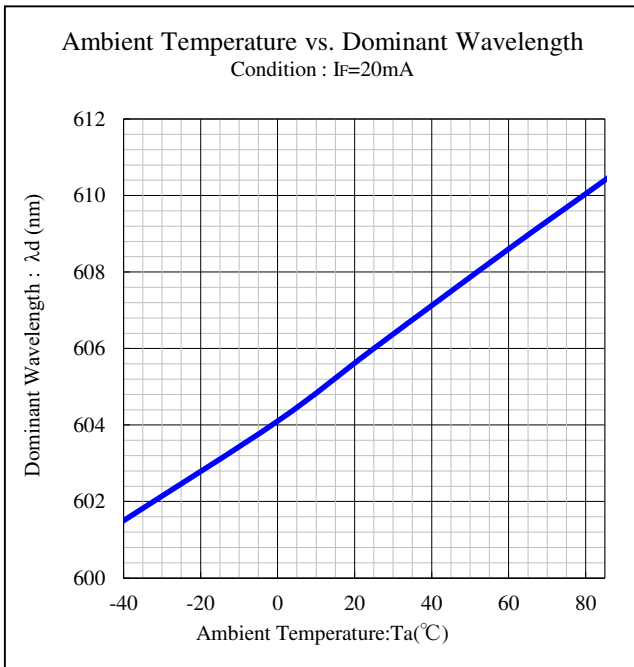
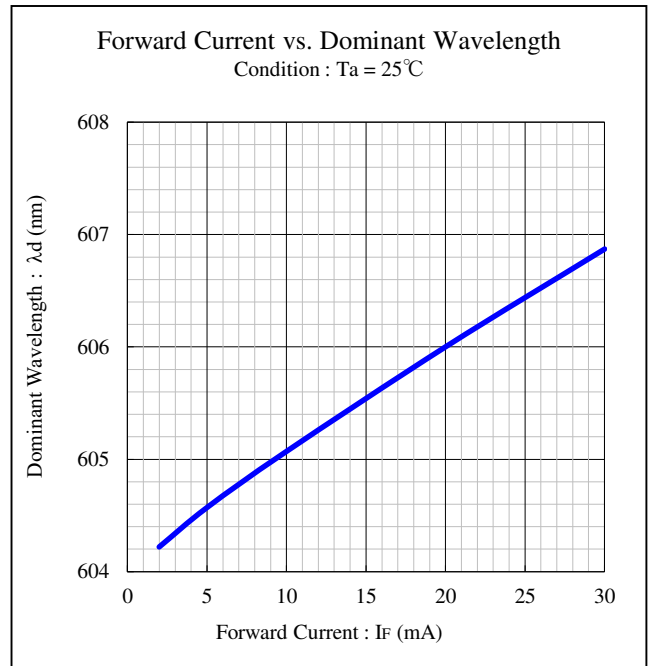
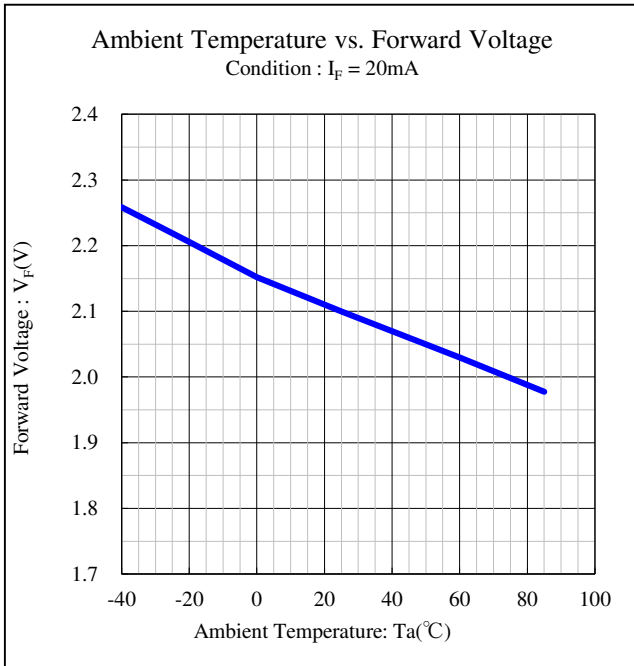

## 【Soldering Precaution】

(acc.to EIAJ-4701/300)

1. Heat stress during soldering will influence the reliability of LEDs, however that effect will vary on heating method. Also, if components of varying shape are soldered together, it is recommended to set the soldering pad temperature according to the component most vulnerable to heat (e.g., surface mount LED).
2. LED parts including the resin are not stable immediately after soldering ( when they are not at room temperature), any mechanical stress may cause damage to the product. Please avoid such stress after soldering, especially stacking of the boards which may cause the boards to warp and any other types of friction with hard materials.
3. Recommended temperature profile for the Reflow soldering is listed as the temperature of the resin surface. Temperature distribution varies on heating method, PCB material, other components in the assembly, and mounting density.  
Please do not repeat the heating process in Reflow process more than twice.

## 【Recommended reflow soldering condition】

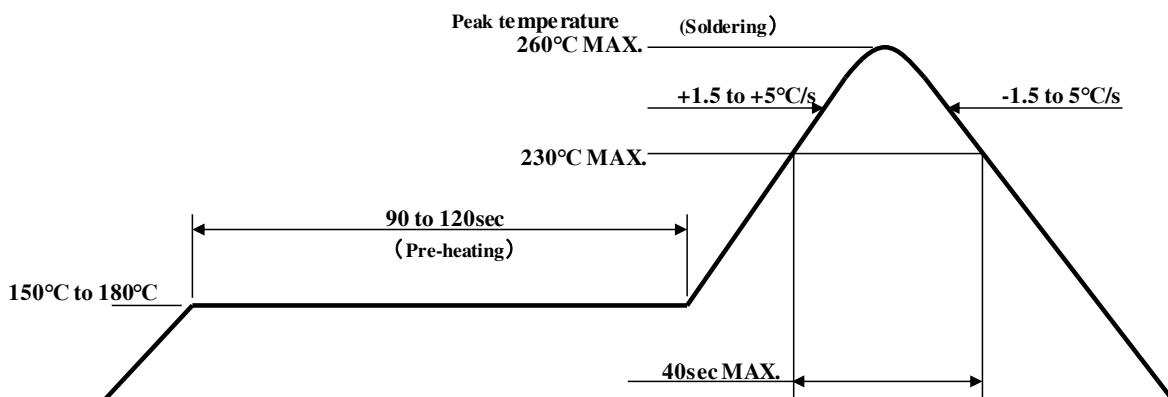

Note 1 Recommended temperature profile for the reflow soldering is listed as the temperature of the resin surface. This should be the maximum temperature for soldering. Lowering the heating temperature and decreasing heating time is very effective in achieving higher reliability.

Note 2 The reflow soldering process should be done up to twice(2 times Max). When second process is performed, interval between first and second process should be as short as possible to prevent absorption of moisture to resin of LED. The second soldering process should not be done until LEDs have returned to room temperature (by nature-cooling) after first soldering process.



4. If soldering manually, Stanley recommends using a soldering iron equipped with temperature control. During the actual soldering process, make sure that the soldering iron never touch the LED itself, and avoid the LED's electrode heating temperature reaching above the heating temperature of the solder pad. All repairs must be performed only once in the same spot, and please avoid reusing components.
5. In soldering process, immediately after iron tip is cleaned, please make sure that the soldering iron reaches the appropriate temperature before using. Also, please avoid applying any type of pressure to the soldered components before the solder has been cooled and hardened, as it may deteriorate solder performance and solder quality.

### 【Recommended Manual Soldering Condition】

Temperature of Iron Tip	350°C MAX.
Soldering Duration, Time	3sec. Max., 1 time

6. When using adhesive material for tentative fixatives, thermosetting resin or Ultraviolet radiation (UV) setting resin with heat shall be recommended.  
《The curing condition, Temperature:150°C Max./Time:120sec. Max.》
7. Flow soldering (dip soldering) is not recommended for this product.
8. Isopropyl alcohol is recommended for cleaning. Some chemicals, including Freon substitute detergent could corrode the lens or the casing surface, which cause discoloration, cloud, crack and so on. Please review the reference chart below for cleaning. If water is used to clean (including the final cleaning process), please use pure water (not tap water), and completely dry the component before using.

Cleaning agents	Recommended / Not recommended
Isopropyl Alcohol	✓ Recommended
Trichloroethylene	x Not recommended
Chloroethene	x Not recommended
Acetone	x Not recommended
Thinner	x Not recommended

## 【 Other Precautions 】

1. Stanley LED Lamps have semiconductor characteristics and are designed to ensure high reliability. However, the performance may vary depending on usage conditions
2. Absolute Maximum Ratings are set to prevent LED lamps from failing due to excess stress( temperature, current, voltage, etc.). Usage conditions must not exceed the ratings for a moment, nor do reach one item of absolute maximum ratings simultaneously.
3. In order to ensure high reliability from LED Lamps, variable factors that arise in actual usage conditions should be taken into account for designing. ( Derating of TYP., MAX Forward Voltage, etc.)
4. Please insert Straight Protective Resistors into the circuit in order to stabilize LED operation and to prevent the device from igniting due to excess current.
5. Please avoid the stick of foreign material because molding resin in the products have adhesiveness. Also please don't touch lens portion.
6. Please check the actual performance in the assembly because the Specification Sheets are described for LED device only.
7. Please refrain from looking directly at the light source of LED at high output, as it may harm your vision.
8. The products are designed to operate without failure in recommended usage conditions. However, please take the necessary precautions to prevent fire, injury, and other damages should any malfunction or failure arise.
9. The products are manufactured to be used for ordinary electronic equipment. Please contact our sales staff beforehand when exceptional quality and reliability are required, and the failure or malfunction of the products might directly jeopardize life or health ( such as for airplanes, aerospace, transport equipment, medical applications, nuclear reactor control systems and so on).
10. When there is a process of supersonic wave welding etc. after mounting the product, there is a possibility of affecting on the reliability of junction part in package (junction part of die bonding and wire bonding). Please make sure there is no problem before using.
11. The formal specification sheets shall be valid only by exchange of documents signed by both parties.

This product is baked (moisture removal) before packaging, and is shipped in moisture-proof packaging (as shown below) to minimize moisture absorption during transportation and storage. However, with regard to storing the products, Stanley recommends the use of dry-box under the following conditions is recommended. Moisture-proof bag as the packaging is made of anti-static material but packaging box is not.

### 【Recommended Storage Condition / Products Warranty Period】

Temperature	+5 to 30°C
Humidity	Under 70%

In the case of the package unopened , 6 months under 【 Recommended Storage Condition 】, Please avoid rapid transition from low temp. condition to high temp. condition and storage in corroding and dusty environment.

### 【Time elapsed after Package Opening】

The package should not be opened until immediately prior to its use, and please keep the time frame between package opening and soldering as is 【maximum 3days(72h)】.

If the device needs to be soldered twice, both soldering operations must be completed within the 3days(72h).

If any components should remain unused, please reseal the package and store them under the conditions described in the 【 Recommended Storage Condition 】, above.

This product must be required to perform baking process (moisture removal) for at 23h( MIN.) at 60+/-5 degrees Celsius if following conditions apply.

1. In the case of silica gel (blue) which indicates the moisture level within the package, changes or loses its blue color.
2. In the case of time passes for 3days(72h) after the package is opened once.

Baking process should be performed after LED having been taken out of the package.

Baking may be performed in the tape-reel form , however if it is performed with the reel stacked over one another, it may cause deformation of the reels and taping materials and later obstruct mounting. Please handle only once it has returned to room temperature. Provided that, baking process shall be 2 times MAX.

【Moisture-proof Packaging Specification】

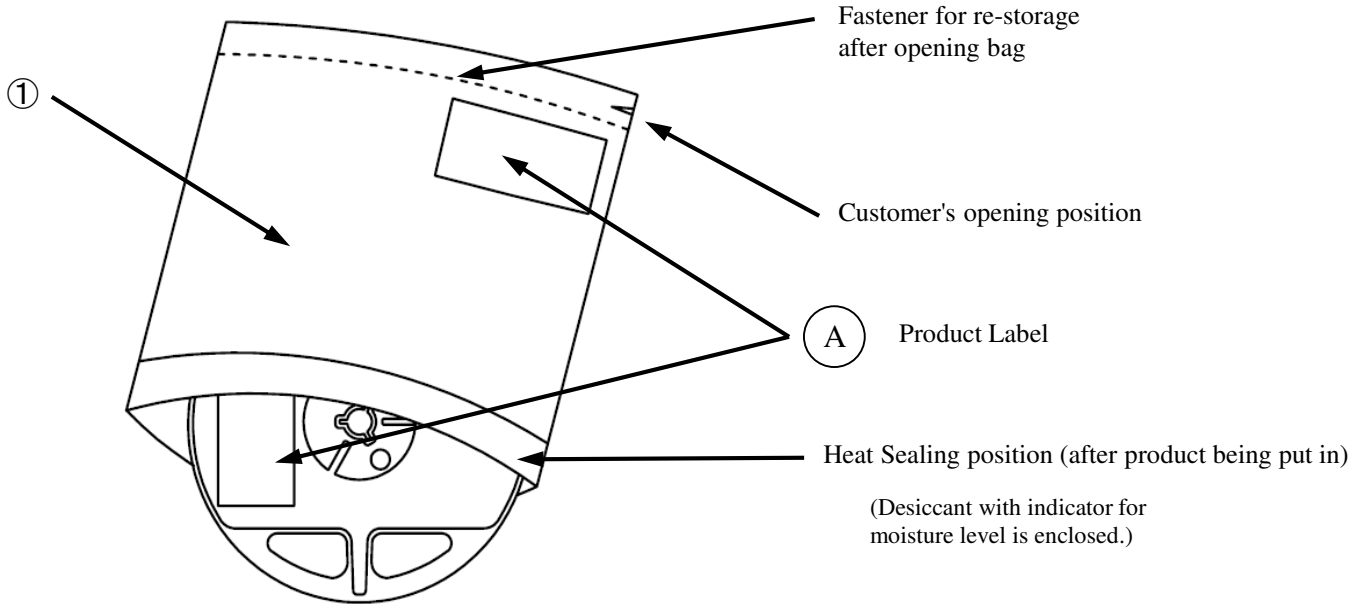

NO.	PART NAME	MATELRIALS	REMARKS
①	Moisture-proof bag with Aluminum layer	PET+Al+PE	with ESD protection

【Flow Chart-package Opening to Mounting】

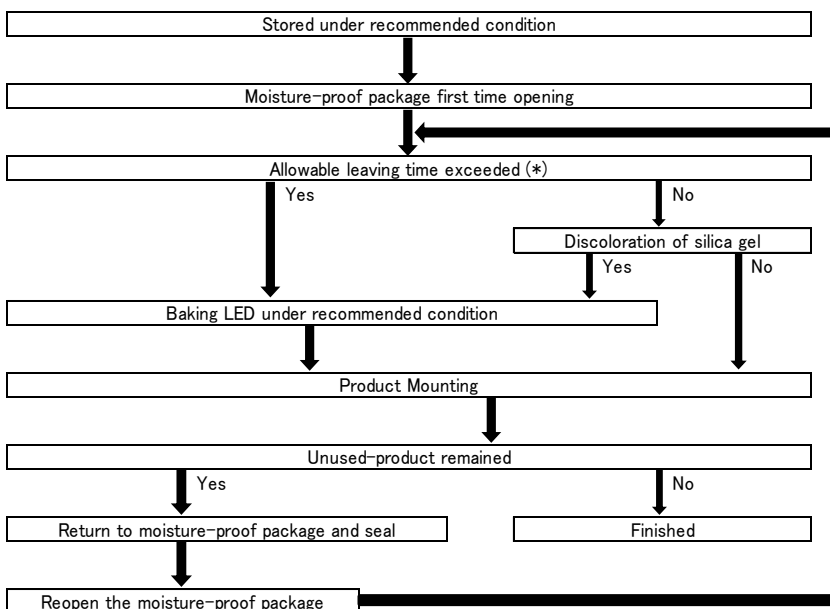

Allowable leaving time means the maximum allowable leaving time after opening package, which depends on each LED type. The allowable leaving time should be calculated from the first opening of package to the time when soldering process is finished. When judging if the allowable leaving time has exceeded or not, please subtract the soldering time. The allowable leaving time after reopening should be calculated from the first opening of package, or from the time when baking process is finished.

【 Packing box 】

(RoHS2/ELV Compliant)

Box Type	Outline dimension L × W × H (mm)	Capacity of the box
Type A	280 × 265 × 45 (mm)	3 reel
Type B	310 × 235 × 265 (mm)	15 reel
Type C	440 × 310 × 265 (mm)	30 reel

The above measure is all the reference value.

The box is selected out of the above table by shipping quantity.

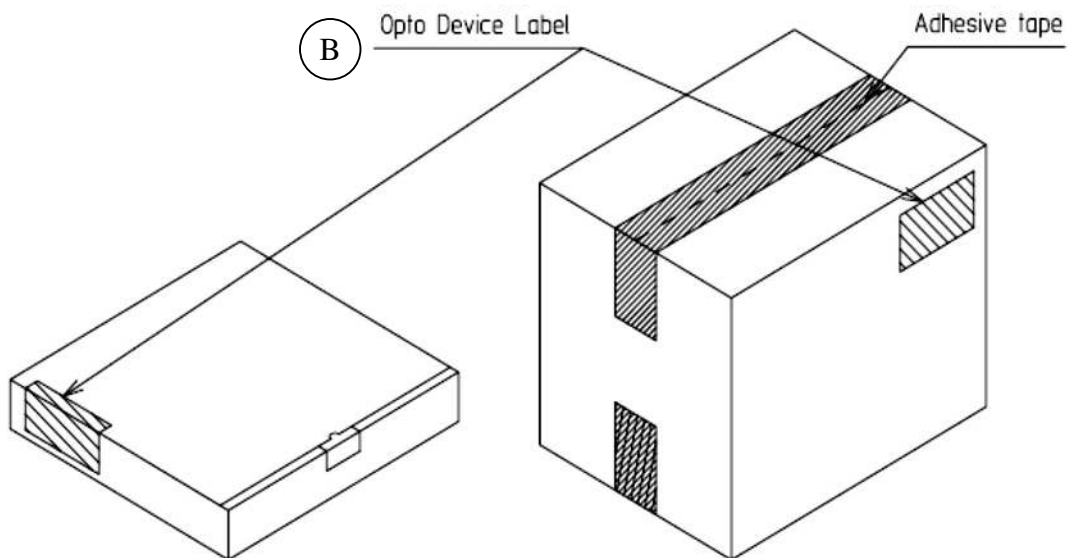

Type A

Material / box : Cardboard C5BF

Type B,C

Material / box : Cardboard K5AF  
Partition : Cardboard K5AF

【 Label Specification】

( acc.to JIS-X0503(Code-39)

(A) Product label

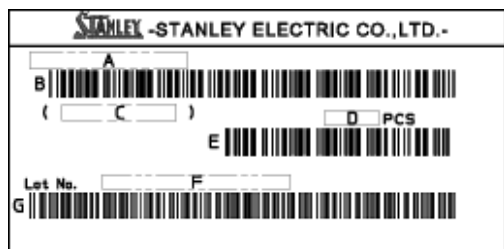

- A. Parts number
- B. Bar-code for parts number
- C. Parts code (In-house identification code for each parts number)
- D. Packed parts quantity
- E. Bar-Code for packed parts quantity
- F. Lot number & Rank  
(refer to Lot Number Notational System for details )
- G. Bar-Code for Lot number & Rank

(B) Opto device label

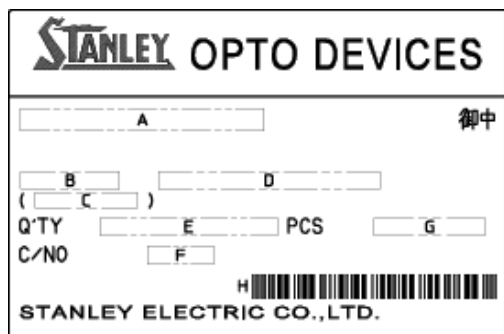

- A. Customer Name
- B. Parts Type
- C. Parts Code
- D. Parts Number
- E. Packed Parts Quantity
- F. Carton Number
- G. Shipping Date
- H. Bar-Code for In-house identification Number

<Remarks> Bar-code font : acc.to Code-39(JIS-X0503)

# Taping and Reel Specifications

FKA1105W-TR/-RR

(acc.to JIS-C0806-03)

## 【Appearance】

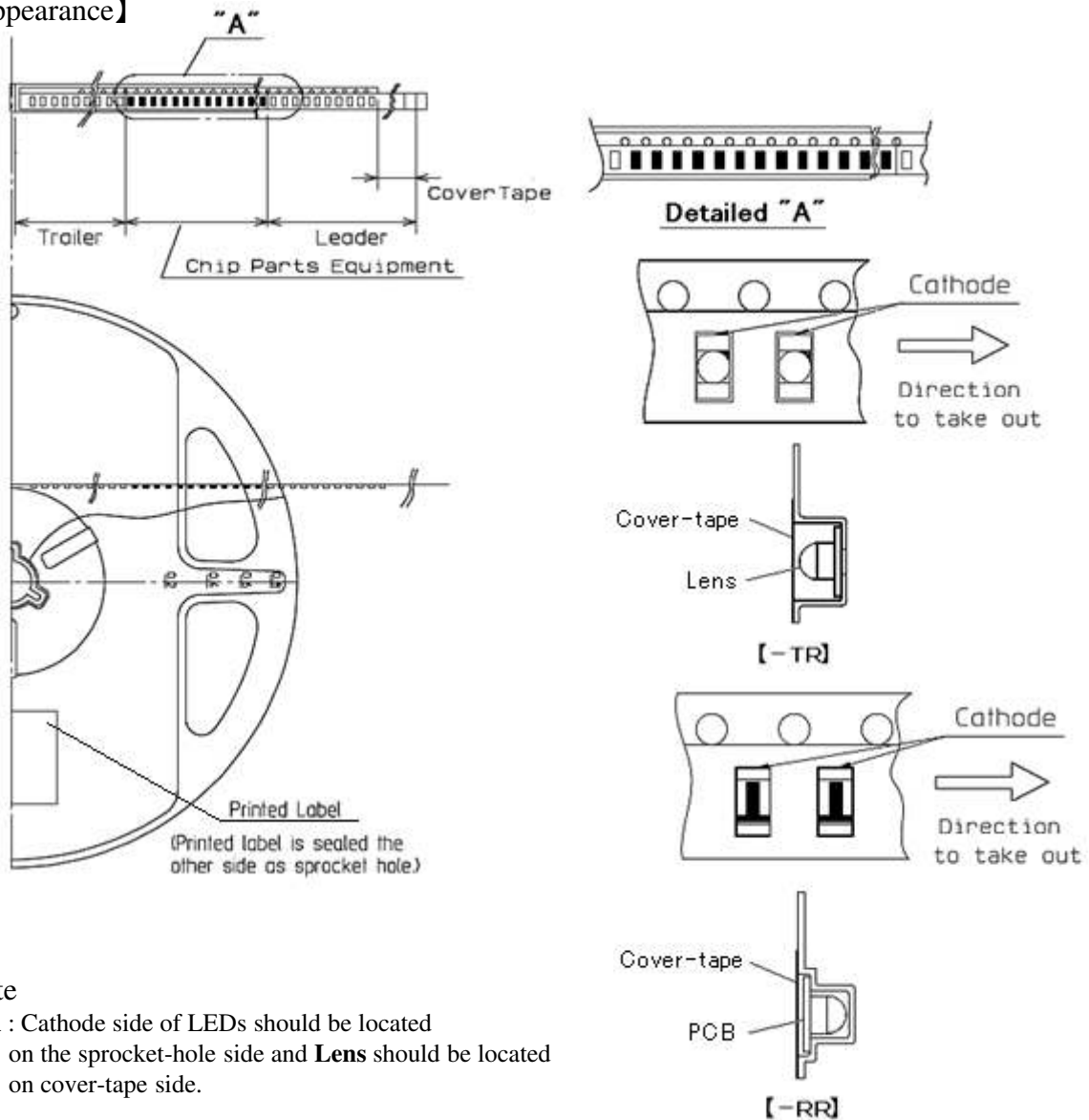

### Note

**-TR** : Cathode side of LEDs should be located on the sprocket-hole side and **Lens** should be located on cover-tape side.

**-RR** : Cathode side of LEDs should be located on the sprocket-hole side and **PCB** should be located on cover-tape side.

Items		Specifications	Remarks
Leader area	Cover-tape	Cover-tape shall be longer than 200mm without carrier-tape	The end of cover-tape shall be held with adhesive tape.
	Carrier-tape	Empty pocket shall be more than 10 pieces.	Please refer to the above figure for Taping & reel orientation .
Trailer area		Empty pocket shall be more than 15 pieces.	The end of taping shall be inserted into a slit of the hub.

# Taping and Reel Specifications

FKA1105W-TR/-RR

Unit : mm

(acc.to JIS-C0806-03)

## 【Taping Dimensions】

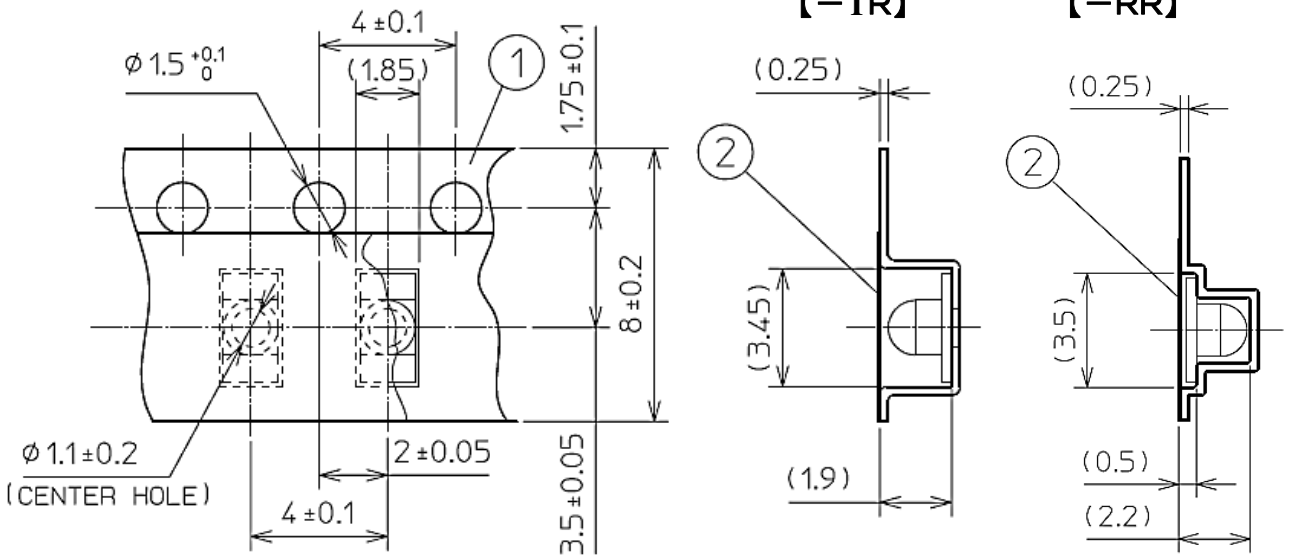

## 【Reel Dimensions】

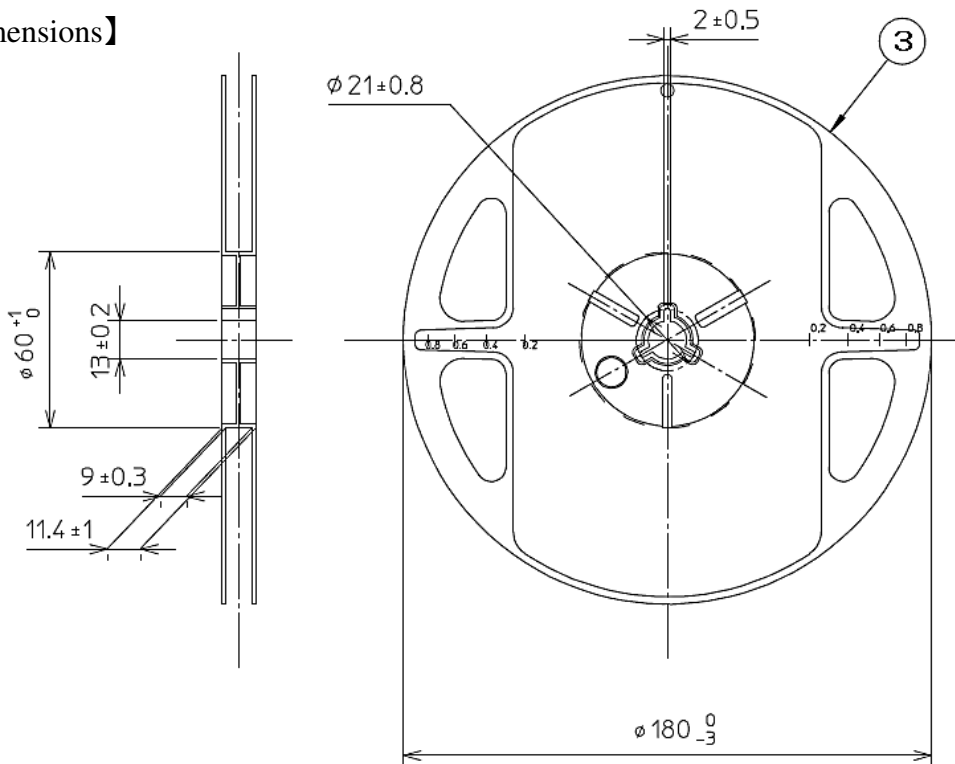

NO.	PART NAME	REMARKS
①	Carrier-tape	with ESD protection
②	Cover-tape	with ESD protection
③	Carrier-reel	with ESD protection



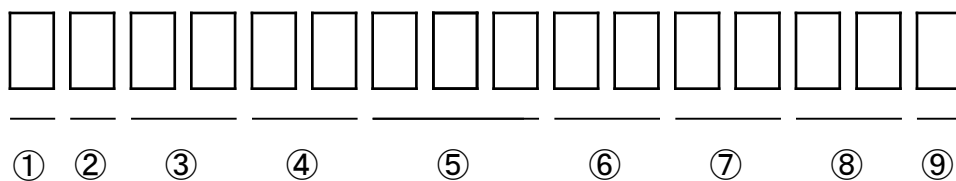

- ① - 1digit : Production location (mark identify alphabet)
- ② - 1digit : Production year (The last digit of production year 2025→5, 2026→6, 2027→7, 2028→8 …)
- ③ - 2digits : Production month (Jan. to Sep. , should be 01,02,03 …)
- ④ - 2digits : Production date
- ⑤ - 3digits : Serial number
- ⑥ - 2digits : Tape and reel following number
- ⑦ - 2digits : Total power rank.  
(If total power rank is 1 digit, "-" shall be dashed on the place for the second digit.  
If there is no identified rank, "- -" is used to indicate.)
- ⑧ - 2digits : Wavelength rank  
(If wavelength rank is 1 digit, "-" shall be dashed on the place for the second digit.  
If there is no identified rank, "- -" is used to indicate.)
- ⑨ - 1digit : VF Rank (If rank is not defined, "-" is described.)

This product is in compliance with RoHS2/ ELV.

Prohibition substance and it's criteria value of RoHS2/ ELV are as follows.

- RoHS2 instruction ... Refer to following 1 to 10.
- ELV instruction ... Refer to following 1 to 4.

No.	Substances	Threshold
1	Lead and its compounds	0.1% (1,000ppm)
2	Mercury and its compounds	0.1% (1,000ppm)
3	Cadmium and its compounds	0.01% (100ppm)
4	Hexavalent chromium compounds	0.1% (1,000ppm)
5	PBB : Polybrominated Biphenyls	0.1% (1,000ppm)
6	PBDE : Polybrominated Biphenyl Ethers	0.1% (1,000ppm)
7	DEHP : Bis (2-ethylhexyl) phthalate	0.1% (1,000ppm)
8	BBP : Butyl benzyl phthalate	0.1% (1,000ppm)
9	DBP : Dibutyl phthalate	0.1% (1,000ppm)
10	DIBP : Diisobutyl phthalate	0.1% (1,000ppm)

## 1. Reliability Testing Result

Test Items	Standards	Test Condition	Duration	Qty.
Operating Life	EIAJ ED-4701 /100 (101)	Ta=25°C I <sub>F</sub> =30mA	1,000h	0 / 25
Resistance to Soldering Heat	EIAJ ED-4701 /300(302)	260°C+/-5°C	5sec or less	0 / 25
Temperature Cycling	EIAJ ED-4701 /100(105)	Ta=-40°C (30min) to Room Temperature (15min) to 120°C (30min) to Room Temperature (15min)	5 cycles	0 / 25
Wet High Temp. Strage Life	EIAJ ED-4701 /100(103)	Ta=60°C+/-2°C Rh=90%+/-5%	1,000h	0 / 25
High Temp. Strage Life	EIAJ ED-4701 /200(201)	Ta=120°C	1,000h	0 / 25
Low Temp. Strage Life	EIAJ ED-4701 /200(202)	Ta=-40°C	1,000h	0 / 10
Vibration, Variable Frequency	EIAJ ED-4701 /400(403)	98.1m/s <sup>2</sup> (10G) 100 to 2000Hz s sweep for 20min each direction X,Y,Z	2h of each	0 / 10

## 2. Failure Criteria

Items	Symbol	Conditions	Failure Criteria
Luminous Intensity	I <sub>V</sub>	I <sub>F</sub> =20mA	Testing Min. Value < Standard Min. Value × 0.5
Forward Voltage	V <sub>F</sub>	I <sub>F</sub> =20mA	Testing Max. Value ≥ Standard Max. Value × 1.2
Reverse Current	I <sub>R</sub>	V <sub>R</sub> =5V	Testing Max. Value ≥ Standard Max. Value × 2.5
Appearance	-	-	Notable discoloration, deformation and cracking

## Special Notice to Customers Using the Products and Technical Information Shown in This Data Sheet

- 1) The technical information shown in the data sheets are limited to the typical characteristics and circuit examples of the referenced products. It does not constitute the warranting of industrial property nor the granting of any license.
- 2) For the purpose of product improvement, the specifications, characteristics and technical data described in the data sheets are subject to change without prior notice. Therefore it is recommended that the most updated specifications be used in your design.
- 3) When using the products described in the data sheets, please adhere to the maximum ratings for operating voltage, heat dissipation characteristics, and other precautions for use. We are not responsible for any damage which may occur if these specifications are exceeded.
- 4) The products that have been described to this catalog are manufactured so that they will be used for the electrical instrument of the benchmark (OA equipment, telecommunications equipment, AV machine, home appliance and measuring instrument).  
The application of aircrafts, space borne application, transportation equipment, medical equipment and nuclear power control equipment, etc. needs a high reliability and safety, and the breakdown and the wrong operation might influence the life or the human body. Please consult us beforehand if you plan to use our product for the usages of aircrafts, space borne application, transportation equipment, medical equipment and nuclear power control equipment, etc. except OA equipment, telecommunications equipment, AV machine, home appliance and measuring instrument.
- 5) In order to export the products or technologies described in this data sheet which are under the “Foreign Exchange and Foreign Trade Control Law,” it is necessary to first obtain an export permit from the Japanese government.
- 6) No part of this data sheet may be reprinted or reproduced without prior written permission from Stanley Electric Co., Ltd.
- 7) The most updated edition of this data sheet can be obtained from the address below:  
<http://www.stanley-components.com/en>