

MOSFET

Metal Oxide Semiconductor Field Effect Transistor

CoolMOS™ CFD2 650V

650V CoolMOS™ CFD2 Power Transistor
IPx65R660CFD

Data Sheet

Rev. 2.7
Final

Industrial & Multimarket

1 Description

CoolMOS™ is a revolutionary technology for high voltage power MOSFETs, designed according to the superjunction (SJ) principle and pioneered by Infineon Technologies. 650V CoolMOS™ CFD2 series combines the experience of the leading SJ MOSFET supplier with high class innovation. The resulting devices provide all benefits of a fast switching SJ MOSFET while offering an extremely fast and robust body diode. This combination of extremely low switching, commutation and conduction losses together with highest robustness make especially resonant switching applications more reliable, more efficient, lighter, and cooler.

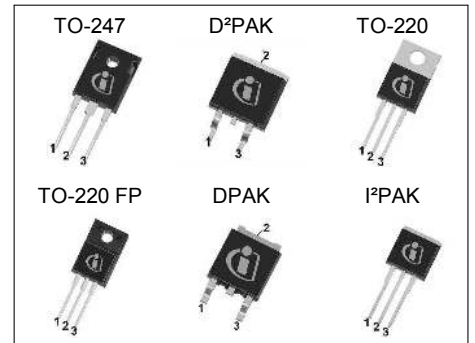

Features

- Ultra-fast body diode
- Very high commutation ruggedness
- Extremely low losses due to very low FOM $R_{ds(on)} \cdot Q_g$ and E_{oss}
- Easy to use/drive
- Fully qualified according to JEDEC for Industrial Applications
- Pb-free plating, available in Halogen free mold compound^{a)}

Applications

650V CoolMOS™ CFD2 is especially suitable for resonant switching PWM stages for e.g. PC Silverbox, LCD TV, Lighting, Server, Telecom, and Solar.

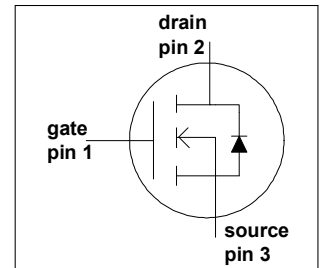

Table 1 Key Performance Parameters

| Parameter | Value | Unit |
|-----------------------|-------|------------|
| $V_{DS} @ T_{j \max}$ | 700 | V |
| $R_{DS(on),max}$ | 0.66 | Ω |
| Q_g,typ | 22 | nC |
| $I_D,pulse$ | 17 | A |
| $E_{oss} @ 400V$ | 1.8 | μJ |
| Body diode di/dt | 900 | A/ μs |
| Q_{rr} | 0.2 | μC |
| t_{rr} | 65 | ns |
| I_{rrm} | 4.5 | A |

| Type / Ordering Code | Package | Marking | Related Links |
|----------------------|-------------------|---------|----------------|
| IPW65R660CFD | PG-TO 247 | 65F6660 | see Appendix A |
| IPB65R660CFD | PG-TO 263 | | |
| IPP65R660CFD | PG-TO 220 | | |
| IPA65R660CFD | PG-TO 220 FullPAK | | |
| IPD65R660CFD | PG-TO 252 | | |
| IPI65R660CFD | PG-TO 262 | | |



Table of Contents

Description 2
Table of Contents 3
Maximum ratings 4
Thermal characteristics 5
Electrical characteristics 6
Electrical characteristics diagrams 8
Test Circuits 13
Package Outlines 14
Appendix A 20
Revision History 21
Disclaimer 21

2 Maximum ratings

at $T_j = 25^\circ\text{C}$, unless otherwise specified

Table 2 Maximum ratings

| Parameter | Symbol | Values | | | Unit | Note / Test Condition |
|---|----------------|--------|------|------|------------------|--|
| | | Min. | Typ. | Max. | | |
| Continuous drain current ¹⁾ | I_D | | | 6.0 | A | $T_C = 25^\circ\text{C}$ |
| | | | | 3.8 | | $T_C = 100^\circ\text{C}$ |
| Pulsed drain current ²⁾ | $I_{D,pulse}$ | | | 17 | A | $T_C = 25^\circ\text{C}$ |
| Avalanche energy, single pulse | E_{AS} | | | 115 | mJ | $I_b = 1.2\text{A}$, $V_{DD} = 50\text{V}$ |
| Avalanche energy, repetitive | E_{AR} | | | 0.21 | mJ | $I_b = 1.2\text{A}$, $V_{DD} = 50\text{V}$ |
| Avalanche current, repetitive | I_{AR} | | | 1.2 | A | |
| MOSFET dv/dt ruggedness | dv/dt | | | 50 | V/ns | $V_{DS} = 0 \dots 400\text{V}$ |
| Gate source voltage | V_{GS} | -20 | | 20 | V | static |
| | | -30 | | 30 | | AC ($f > 1\text{Hz}$) |
| Power dissipation (non FullPAK) TO-247, TO-220, I ² PAK | P_{tot} | | | 62.5 | W | $T_C = 25^\circ\text{C}$ |
| Power dissipation (FullPAK) TO-220 FP | P_{tot} | | | 27.8 | W | $T_C = 25^\circ\text{C}$ |
| Operating and storage temperature | T_j, T_{stg} | -55 | | 150 | $^\circ\text{C}$ | |
| Mounting torque (non FullPAK) TO-247, TO-220, I ² PAK | | | | 60 | Ncm | M3 and M3.5 screws |
| Mounting torque (FullPAK) TO-220 FP | | | | 50 | Ncm | M2.5 screws |
| Continuous diode forward current | I_S | | | 6.0 | A | $T_C = 25^\circ\text{C}$ |
| Diode pulse current | $I_{S,pulse}$ | | | 17 | A | $T_C = 25^\circ\text{C}$ |
| Reverse diode dv/dt ³⁾ | dv/dt | | | 50 | V/ns | $V_{DS} = 0 \dots 400\text{V}$, $I_{SD} \leq I_b$, $T_j = 25^\circ\text{C}$ |
| Maximum diode commutation speed | di_f/dt | | | 900 | A/ μs | |

¹⁾ Limited by $T_{j,max}$.

²⁾ Pulse width t_p limited by $T_{j,max}$

³⁾ $V_{peak} < V_{(BR)DSS}$, $T_j < T_{j,max}$, identical low side and high side switch with same Rg

3 Thermal characteristics

Table 3 Thermal characteristics TO-247, TO-220, I²PAK

| Parameter | Symbol | Values | | | Unit | Note / Test Condition |
|--|------------|--------|------|------|------|--------------------------------------|
| | | Min. | Typ. | Max. | | |
| Thermal resistance, junction - case | R_{thJC} | | | 2 | °C/W | |
| Thermal resistance, junction - ambient | R_{thJA} | | | 62 | °C/W | leaded |
| Soldering temperature, wavesoldering only allowed at leads | T_{sold} | | | 260 | °C | 1.6 mm (0.063 in.) from case for 10s |

Table 4 Thermal characteristics TO-220 FP

| Parameter | Symbol | Values | | | Unit | Note / Test Condition |
|--|------------|--------|------|------|------|--------------------------------------|
| | | Min. | Typ. | Max. | | |
| Thermal resistance, junction - case | R_{thJC} | | | 4.5 | °C/W | |
| Thermal resistance, junction - ambient | R_{thJA} | | | 80 | °C/W | leaded |
| Soldering temperature, wavesoldering only allowed at leads | T_{sold} | | | 260 | °C | 1.6 mm (0.063 in.) from case for 10s |

Table 5 Thermal characteristics D²PAK, DPAK

| Parameter | Symbol | Values | | | Unit | Note / Test Condition |
|--|------------|--------|------|------|------|---|
| | | Min. | Typ. | Max. | | |
| Thermal resistance, junction - case | R_{thJC} | | | 2 | °C/W | |
| Thermal resistance, junction - ambient ¹⁾ | R_{thJA} | | | 62 | °C/W | SMD version, device on PCB, minimal footprint |
| | | | 35 | | | SMD version, device on PCB, 6cm ² cooling area |
| Soldering temperature, wave- & reflowsoldering allowed | T_{sold} | | | 260 | °C | reflow MSL |

¹⁾ Device on 40mm*40mm*1.5mm one layer epoxy PCB FR4 with 6cm² copper area (thickness 70µm) for drain connection. PCB is vertical without air stream cooling.

4 Electrical characteristics

at $T_j = 25^\circ\text{C}$, unless otherwise specified

Table 6 Static characteristics

| Parameter | Symbol | Values | | | Unit | Note / Test Condition |
|----------------------------------|---------------|--------|-------|------|----------|---|
| | | Min. | Typ. | Max. | | |
| Drain-source breakdown voltage | $V_{(BR)DSS}$ | 650 | | | V | $V_{GS} = 0V, I_D = 1mA$ |
| Gate threshold voltage | $V_{GS(th)}$ | 3.5 | 4 | 4.5 | V | $V_{DS} = V_{GS}, I_D = 0.2mA$ |
| Zero gate voltage drain current | I_{DSS} | | | 1 | μA | $V_{DS} = 650V, V_{GS} = 0V, T_j = 25^\circ C$ |
| | | | 100 | | | $V_{DS} = 650V, V_{GS} = 0V, T_j = 150^\circ C$ |
| Gate-source leakage current | I_{GSS} | | | 100 | nA | $V_{GS} = 20V, V_{DS} = 0V$ |
| Drain-source on-state resistance | $R_{DS(on)}$ | | 0.594 | 0.66 | Ω | $V_{GS} = 10V, I_D = 2.1A, T_j = 25^\circ C$ |
| | | | 1.544 | | | $V_{GS} = 10V, I_D = 2.1A, T_j = 150^\circ C$ |
| Gate resistance | R_G | | 6.5 | | Ω | $f = 1MHz, \text{open drain}$ |

Table 7 Dynamic characteristics

| Parameter | Symbol | Values | | | Unit | Note / Test Condition |
|--|--------------|--------|------|------|------|---|
| | | Min. | Typ. | Max. | | |
| Input capacitance | C_{iss} | | 615 | | pF | $V_{GS} = 0V, V_{DS} = 100V, f = 1MHz$ |
| Output capacitance | C_{oss} | | 33 | | pF | |
| Effective output capacitance, energy related ¹⁾ | $C_{o(er)}$ | | 21 | | pF | $V_{GS} = 0V, V_{DS} = 0 \dots 400V$ |
| Effective output capacitance, time related ²⁾ | $C_{o(tr)}$ | | 88 | | pF | $I_D = \text{constant}, V_{GS} = 0V, V_{DS} = 0 \dots 400V$ |
| Turn-on delay time | $t_{d(on)}$ | | 9 | | ns | $V_{DD} = 400V, V_{GS} = 13V, I_D = 3.2A, R_G = 6.8\Omega$ |
| Rise time | t_r | | 8 | | ns | |
| Turn-off delay time | $t_{d(off)}$ | | 40 | | ns | |
| Fall time | t_f | | 10 | | ns | |

Table 8 Gate charge characteristics

| Parameter | Symbol | Values | | | Unit | Note / Test Condition |
|-----------------------|---------------|--------|------|------|------|---|
| | | Min. | Typ. | Max. | | |
| Gate to source charge | Q_{gs} | | 3.5 | | nC | $V_{DD} = 480V, I_D = 3.2A, V_{GS} = 0 \text{ to } 10V$ |
| Gate to drain charge | Q_{gd} | | 12 | | nC | |
| Gate charge total | Q_g | | 22 | | nC | |
| Gate plateau voltage | $V_{plateau}$ | | 6.4 | | V | |

¹⁾ $C_{o(er)}$ is a fixed capacitance that gives the same stored energy as C_{oss} while V_{DS} is rising from 0 to 400V

²⁾ $C_{o(tr)}$ is a fixed capacitance that gives the same charging time as C_{oss} while V_{DS} is rising from 0 to 400V

Table 9 Reverse diode characteristics

| Parameter | Symbol | Values | | | Unit | Note / Test Condition |
|-------------------------------|-----------|--------|------|------|---------|---|
| | | Min. | Typ. | Max. | | |
| Diode forward voltage | V_{SD} | | 0.9 | | V | $V_{GS} = 0V, I_F = 3.2A, T_j = 25^\circ C$ |
| Reverse recovery time | t_{rr} | | 65 | | ns | $V_R = 400V, I_F = 3.2A,$ $dI/dt = 100A/\mu s$ |
| Reverse recovery charge | Q_{rr} | | 0.2 | | μC | |
| Peak reverse recovery current | I_{rrm} | | 4.5 | | A | |

5 Electrical characteristics diagrams

Table 10

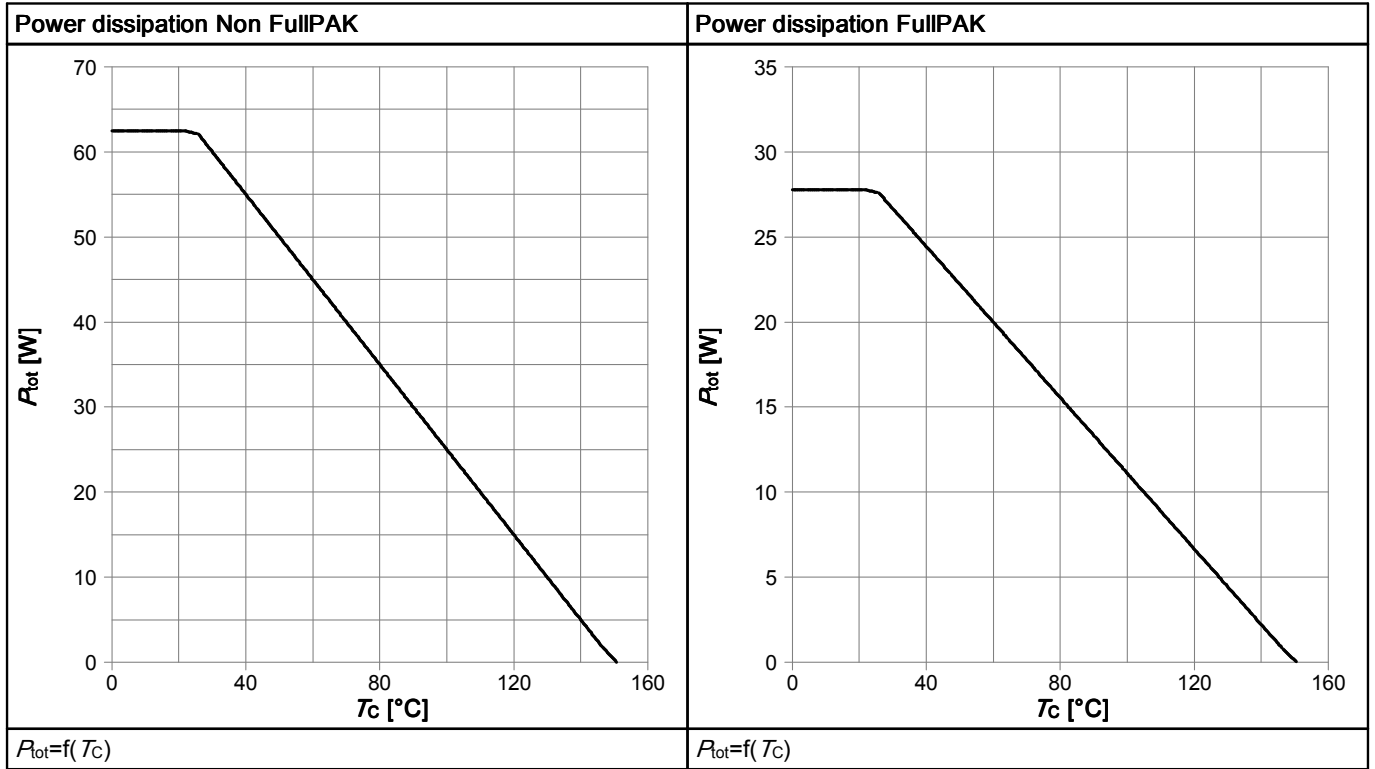

Table 11

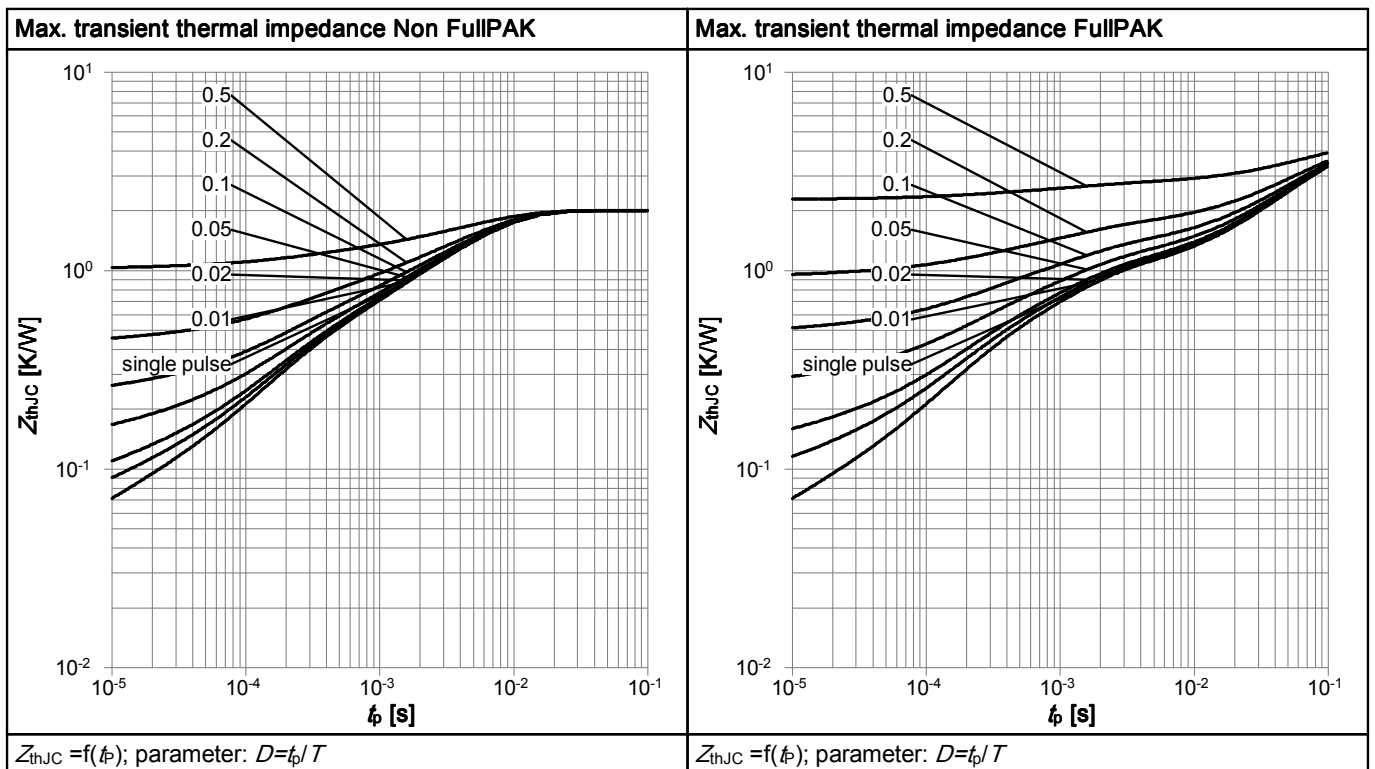

Table 12

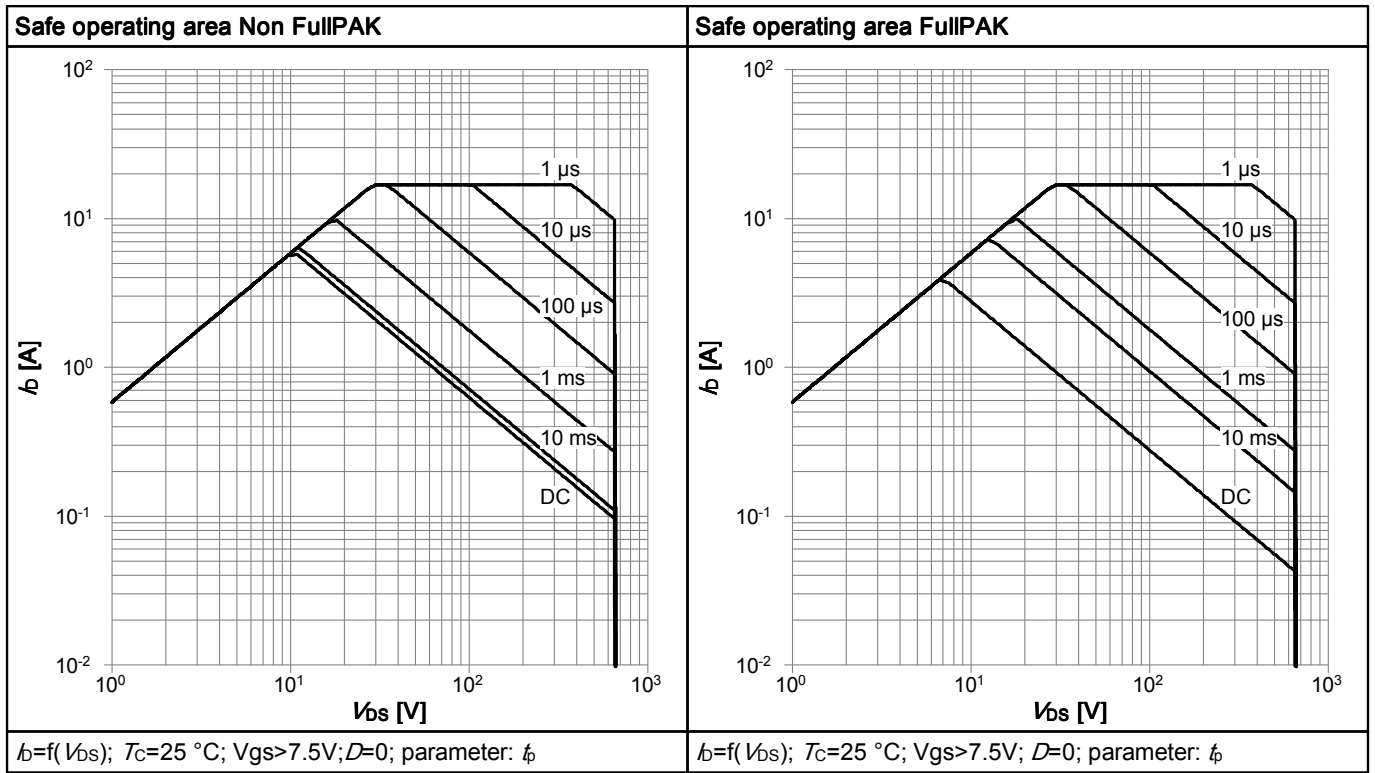

Table 13

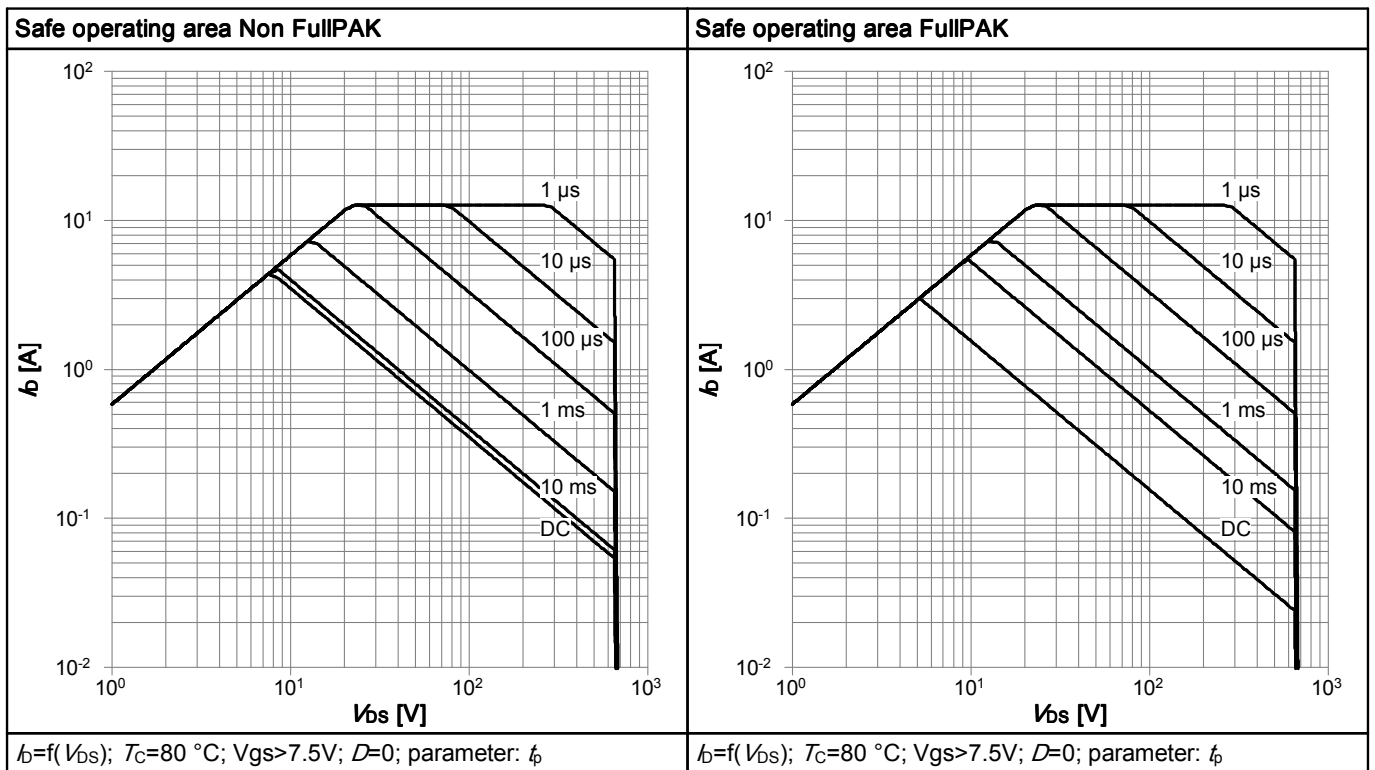

Table 14

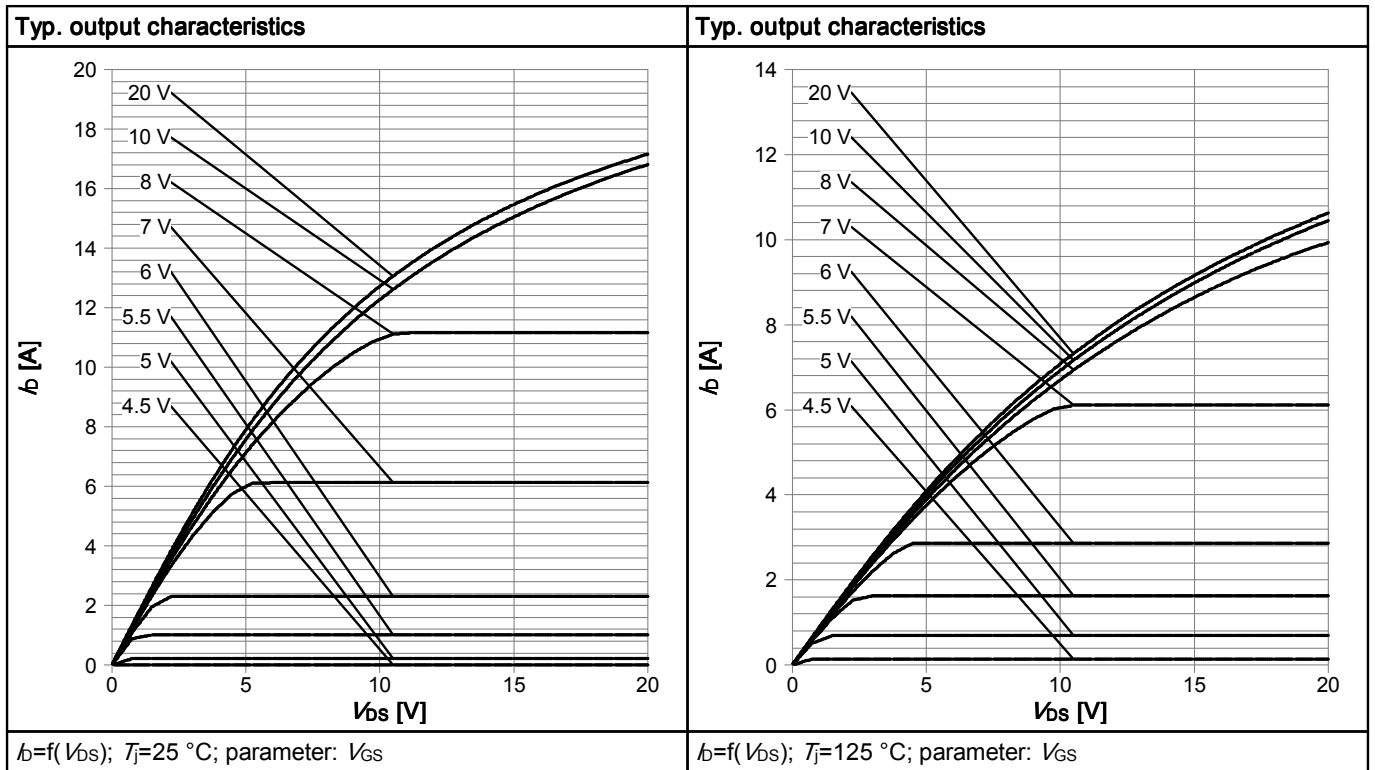

Table 15

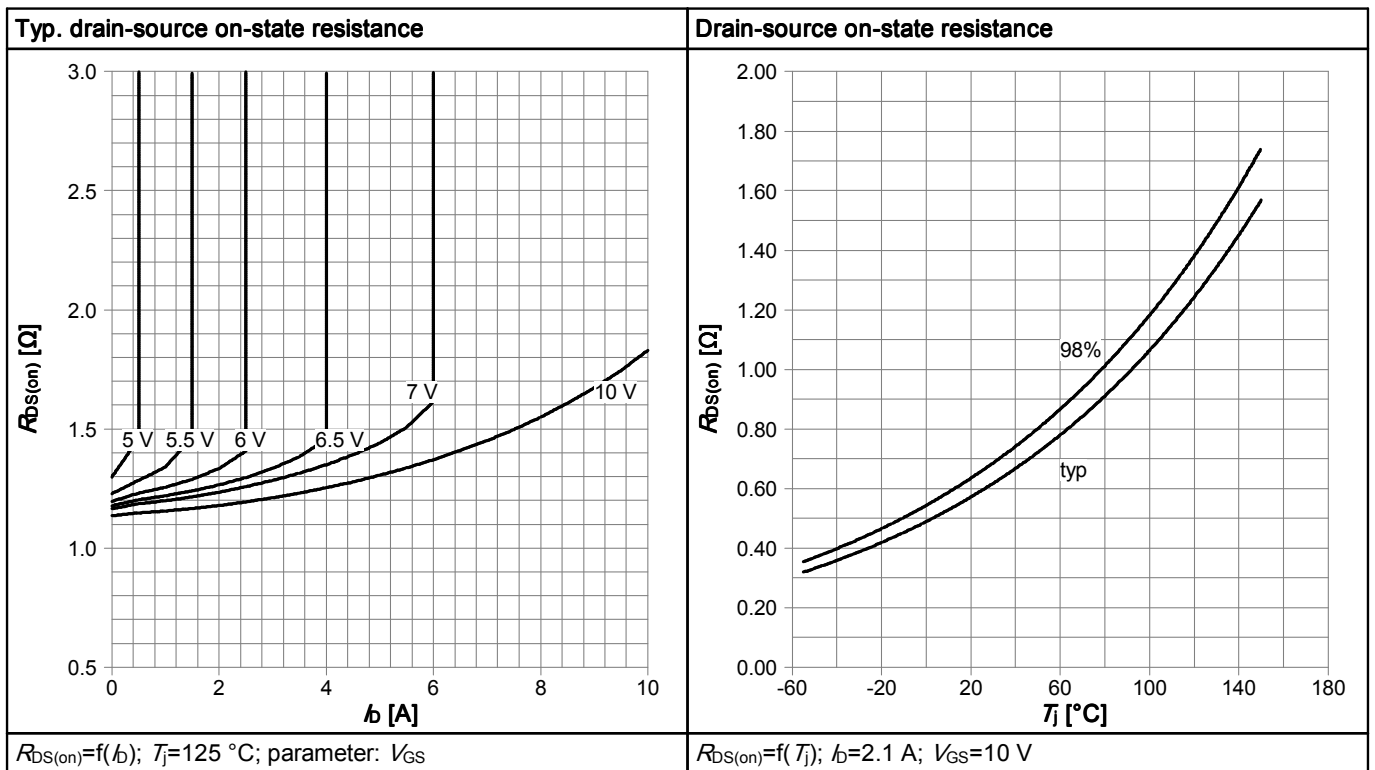

Table 16

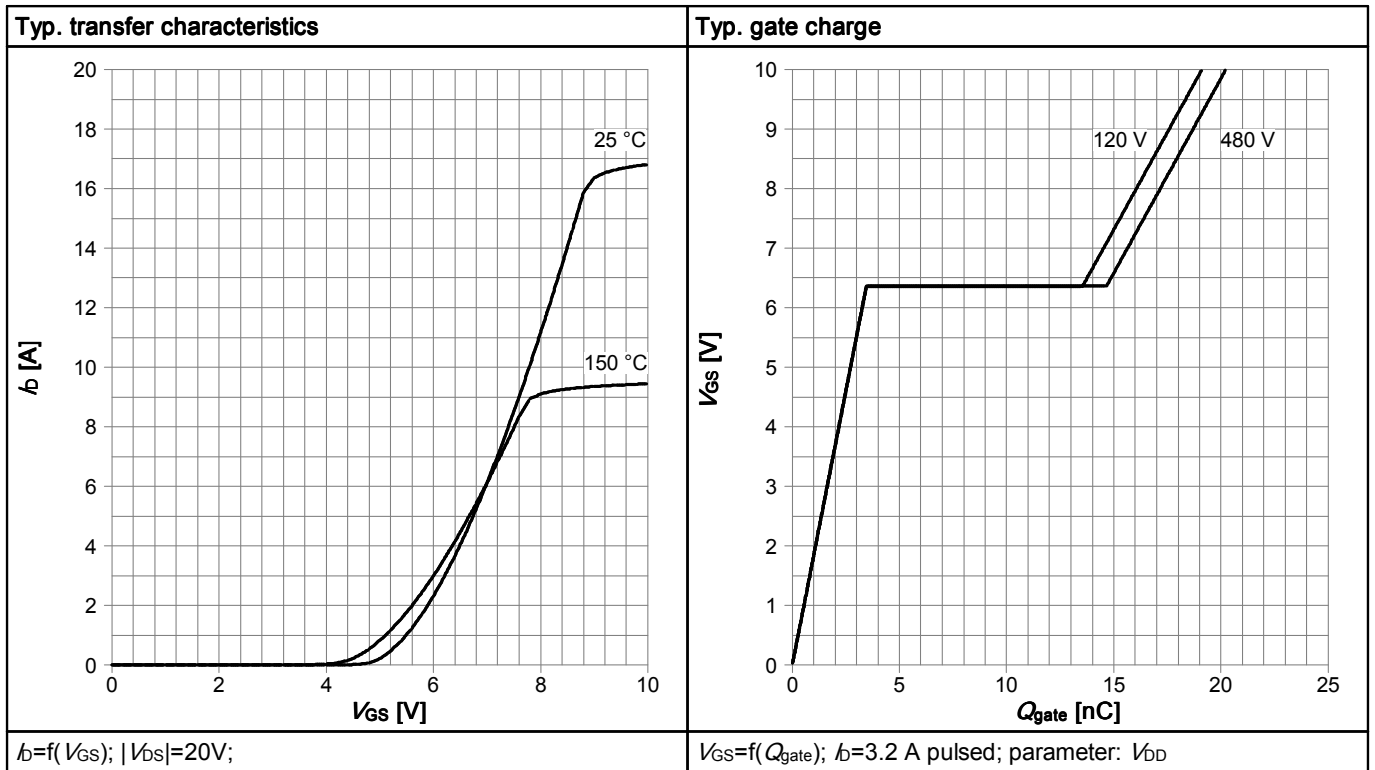

Table 17

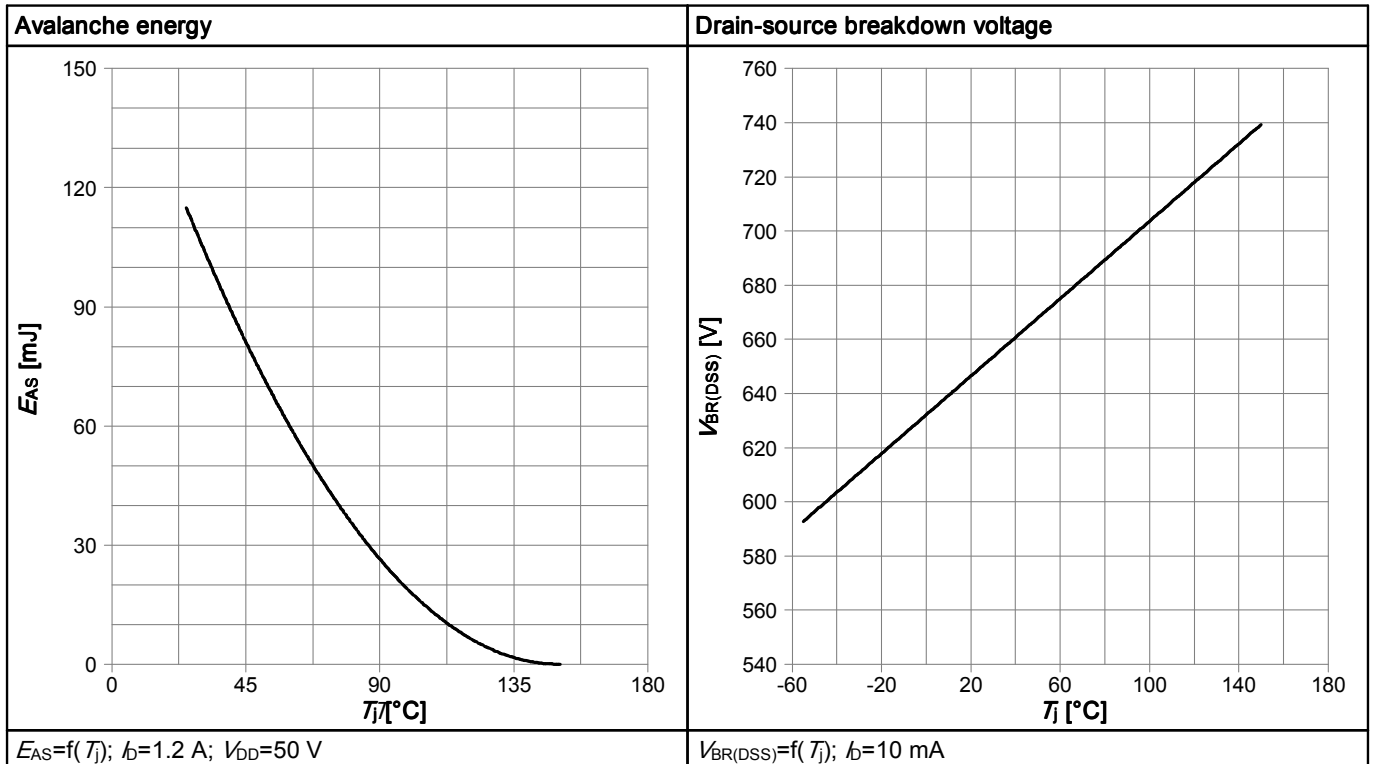

Table 18

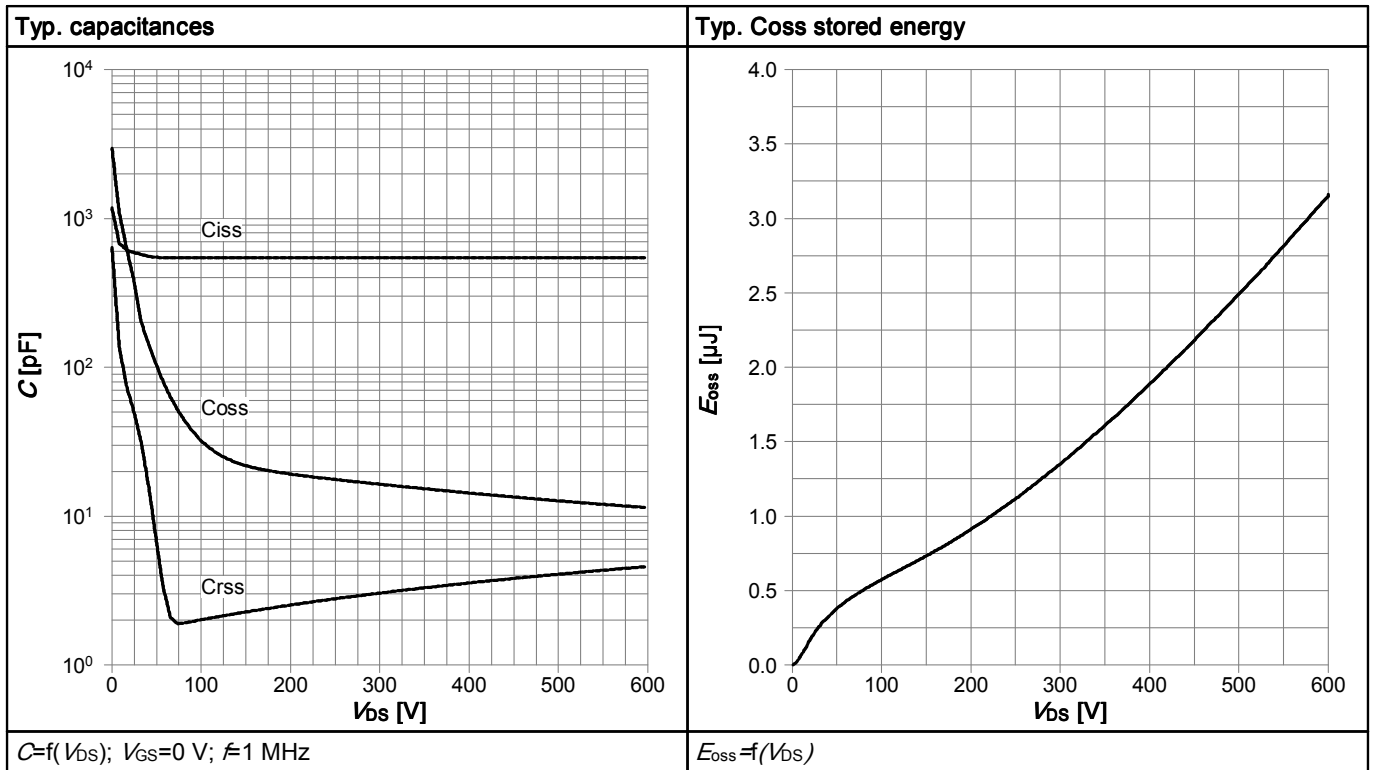
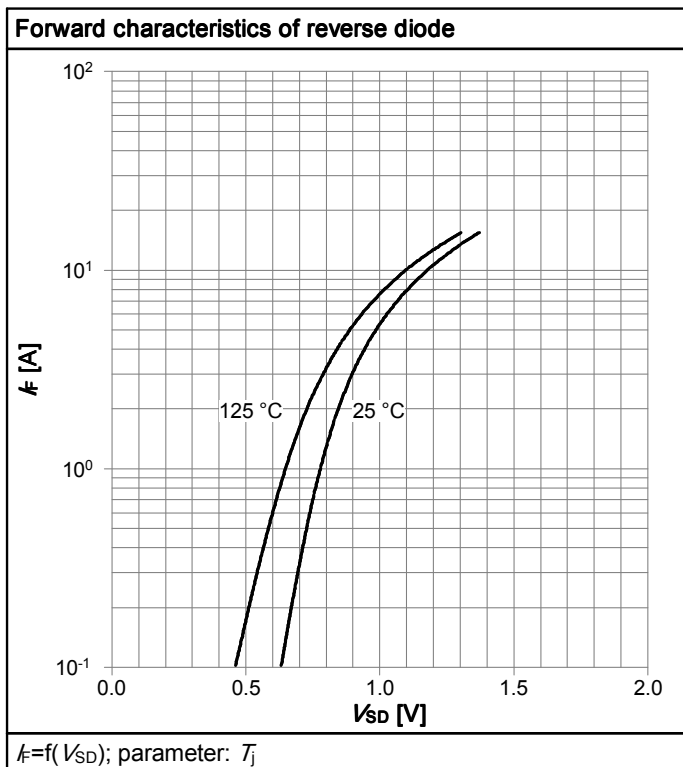

Table 19



6 Test Circuits

Table 20 Diode_characteristics

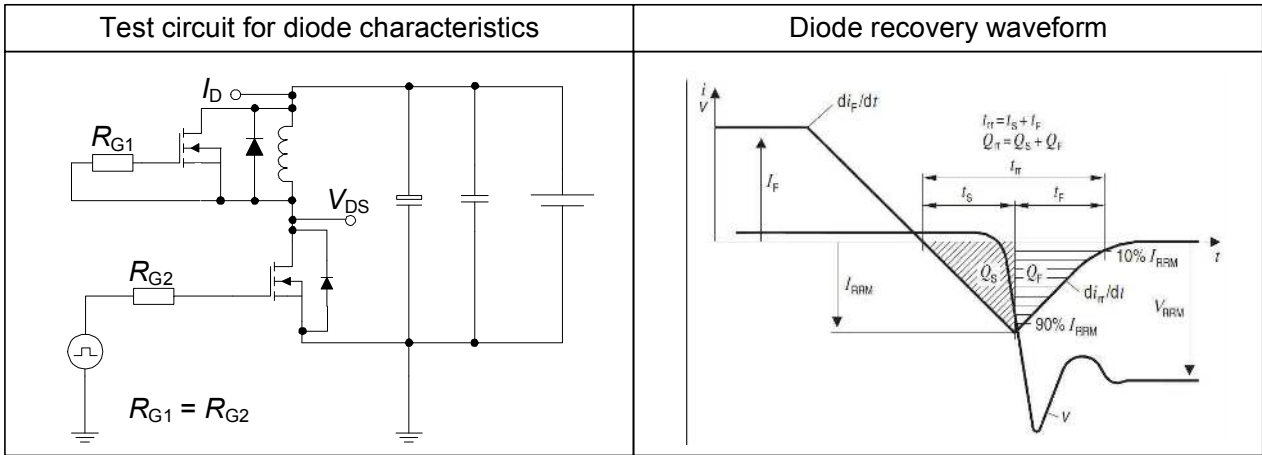

Table 21 Switching_times

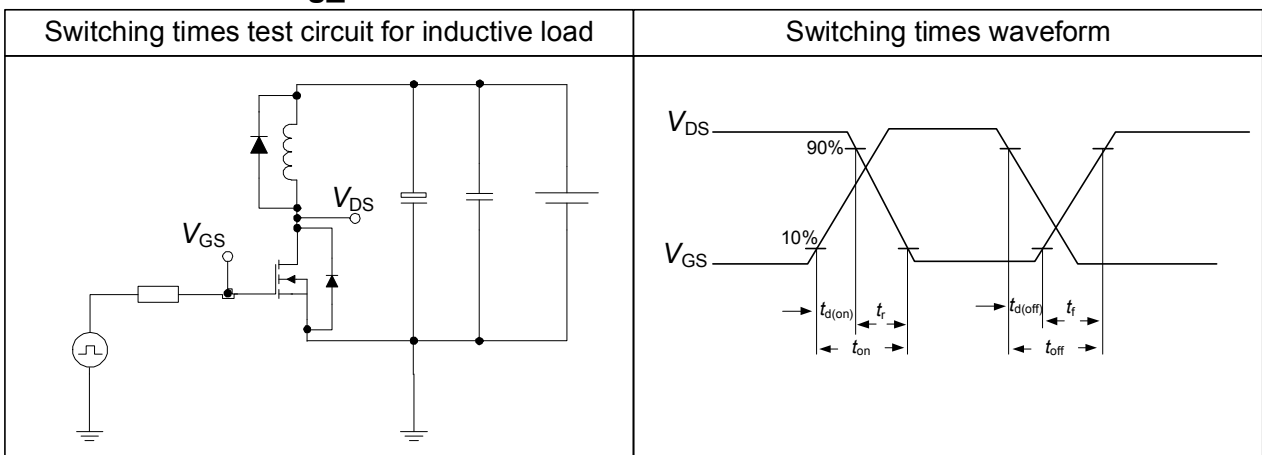
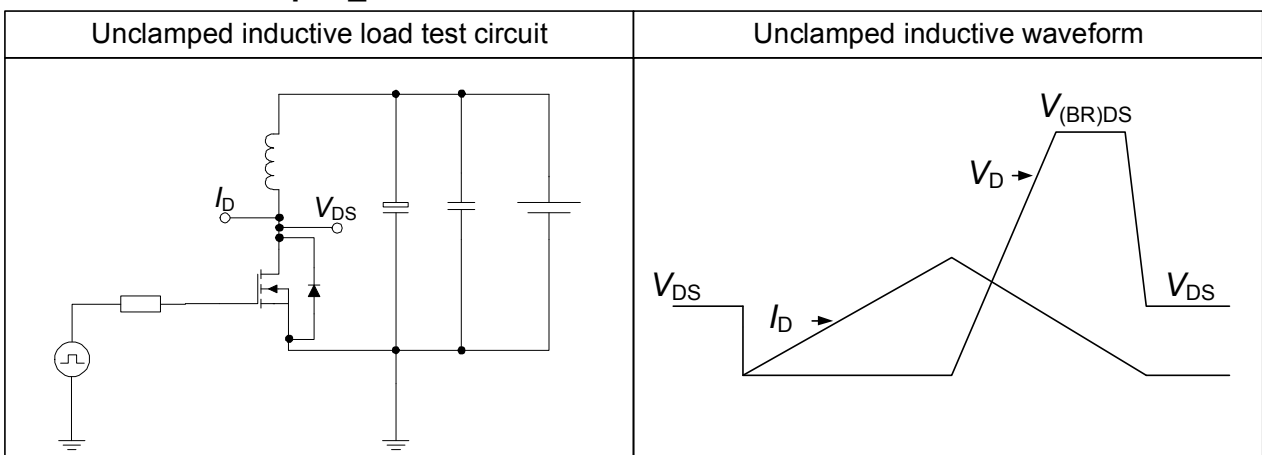

Table 22 Unclamped_inductive



7 Package Outlines

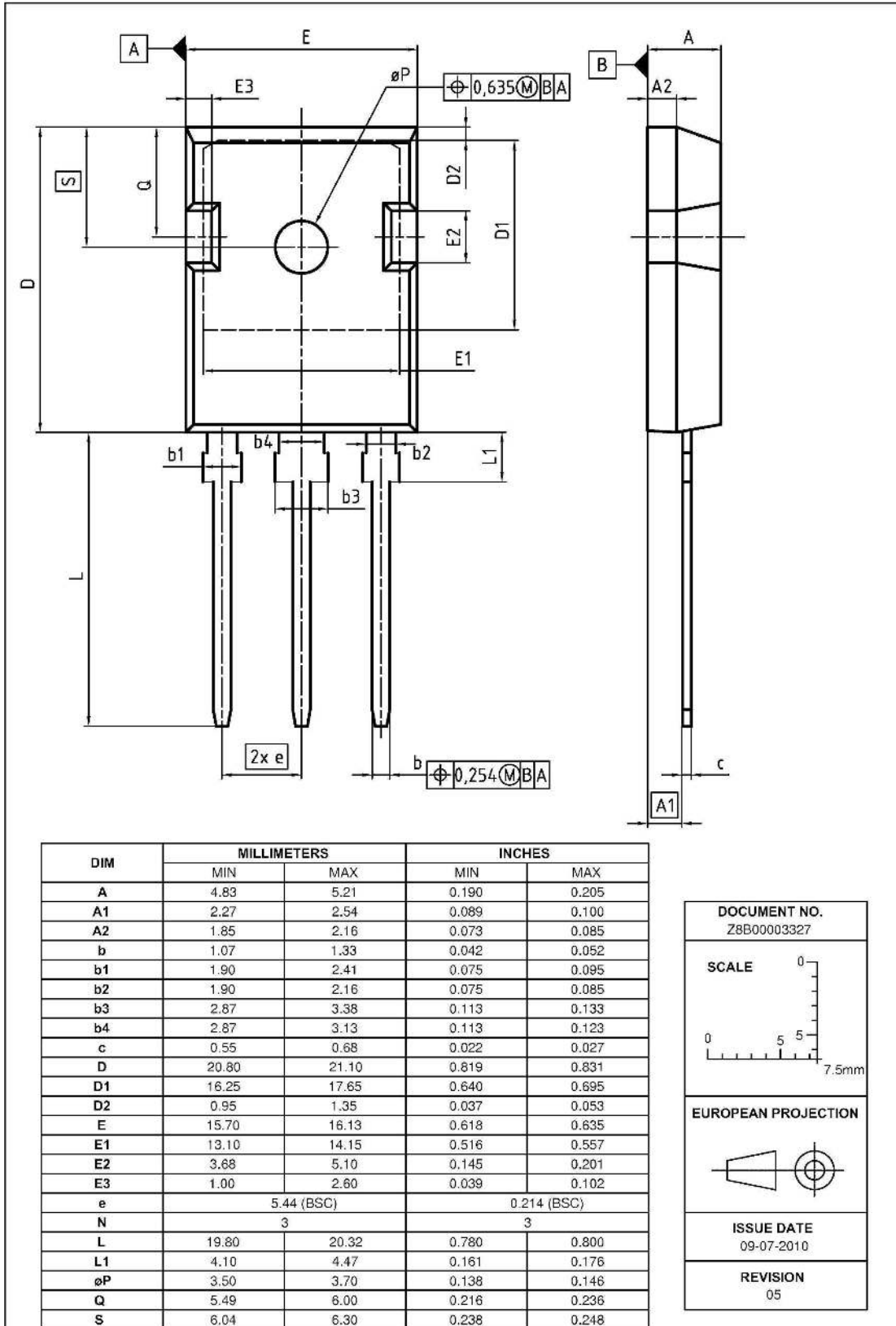

Figure 1 Outline PG-TO 247, dimensions in mm/inches

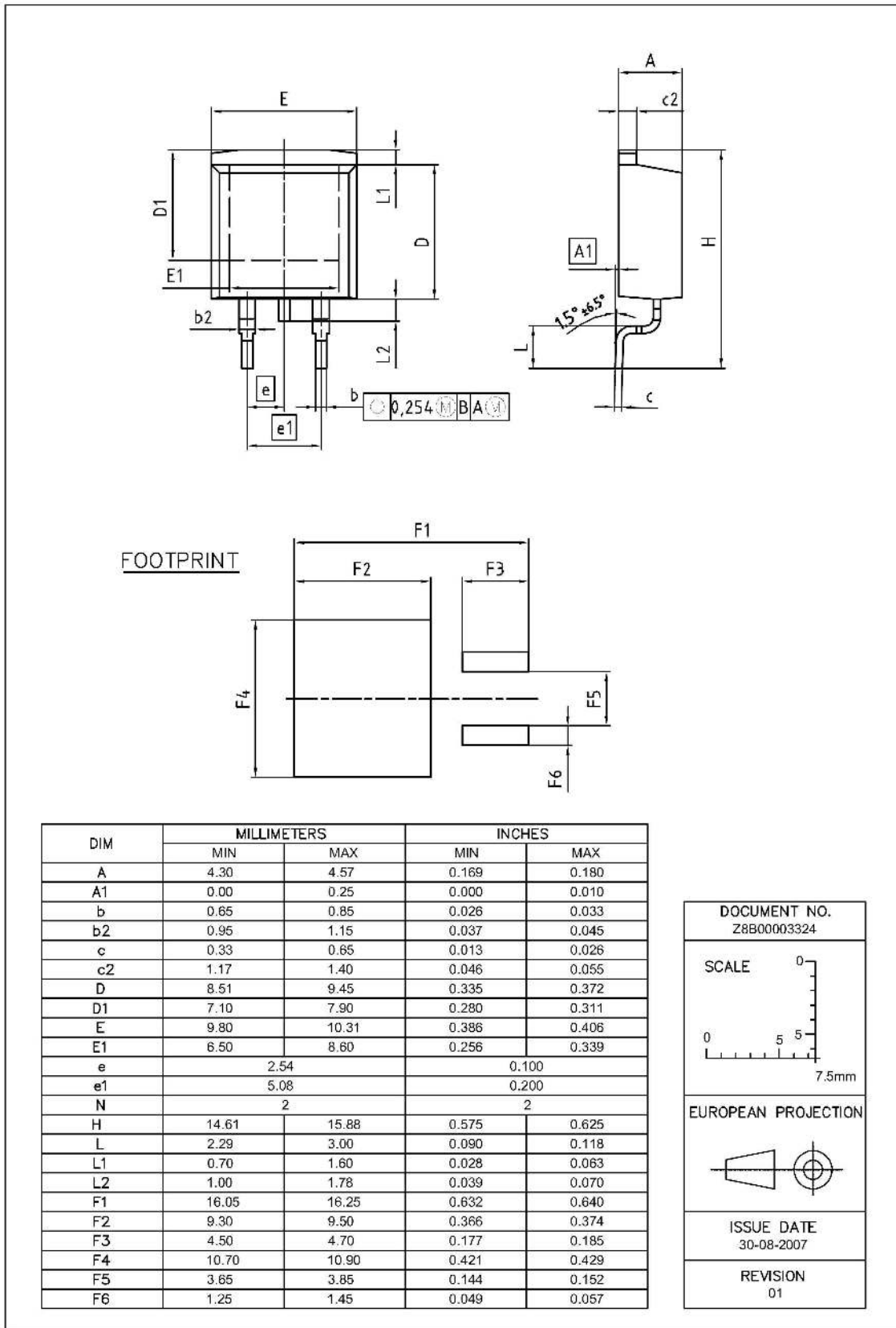

Figure 2 Outline PG-TO 263, dimensions in mm/inches

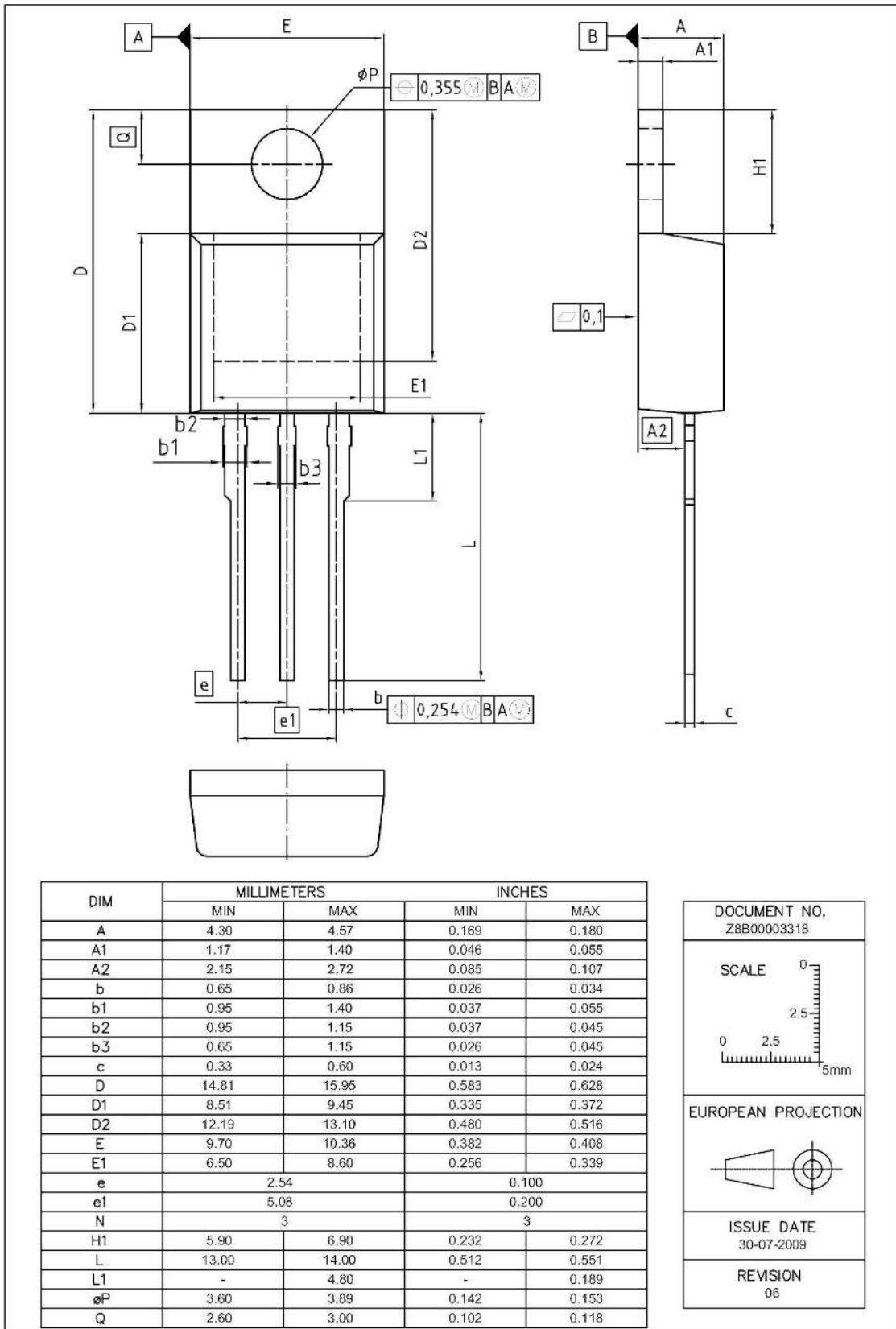

Figure 3 Outline PG-TO 220, dimensions in mm/inches

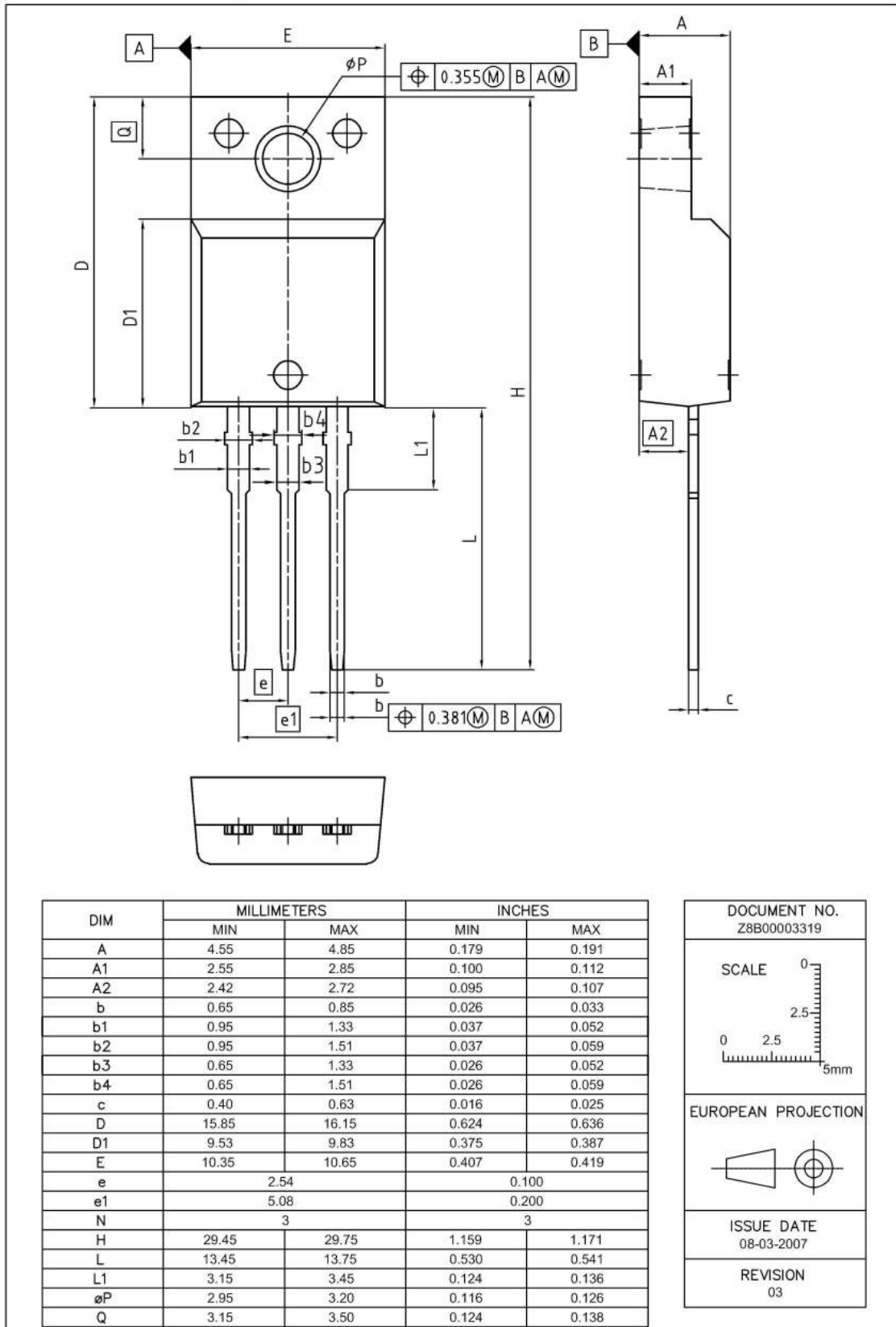
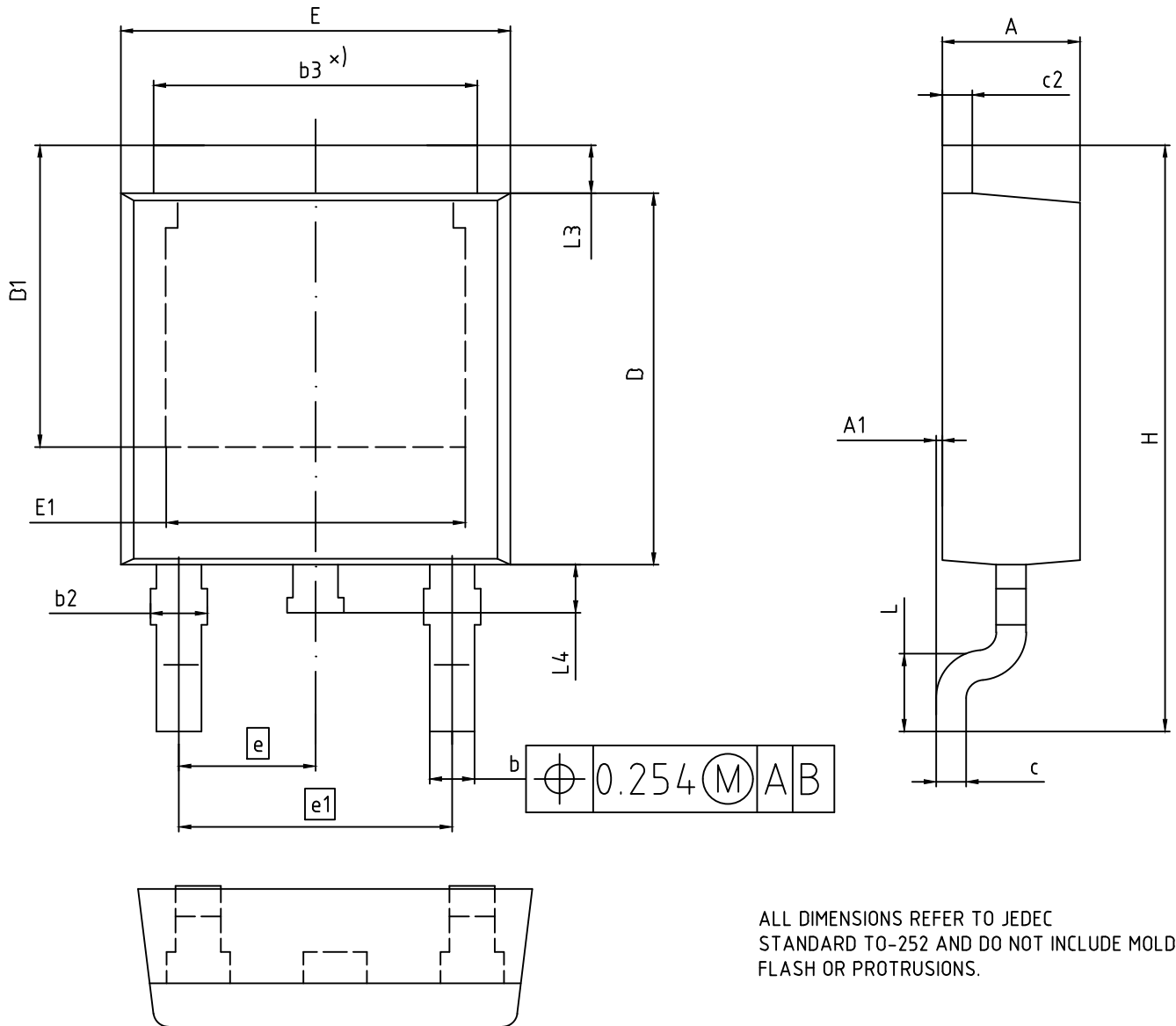

Figure 4 Outline PG-TO 220 FullPAK, dimensions in mm/inches

7 Package Outlines



ALL DIMENSIONS REFER TO JEDEC STANDARD TO-252 AND DO NOT INCLUDE MOLD FLASH OR PROTRUSIONS.

| DIMENSION | MILLIMETERS | |
|-----------|-------------|-------|
| | MIN. | MAX. |
| A | 2.16 | 2.41 |
| A1 | 0.00 | 0.15 |
| b | 0.64 | 0.89 |
| b2 | 0.65 | 1.15 |
| b3 | 4.95 | 5.50 |
| c | 0.46 | 0.61 |
| c2 | 0.40 | 0.98 |
| D | 5.97 | 6.22 |
| D1 | 5.02 | 5.84 |
| E | 6.35 | 6.73 |
| E1 | 4.32 | 5.50 |
| e | 2.29 | |
| e1 | 4.57 | |
| N | 3 | |
| H | 9.40 | 10.48 |
| L | 1.18 | 1.78 |
| L3 | 0.89 | 1.27 |
| L4 | 0.51 | 1.02 |

| |
|--------------------------------------|
| DOCUMENT NO. Z8B00003328 |
| REVISION 07 |
| SCALE: 10:1 0 1 2mm |
| EUROPEAN PROJECTION |
| ISSUE DATE 01.04.2020 |

Figure 5 Outline PG-TO 252, dimensions in mm/inches

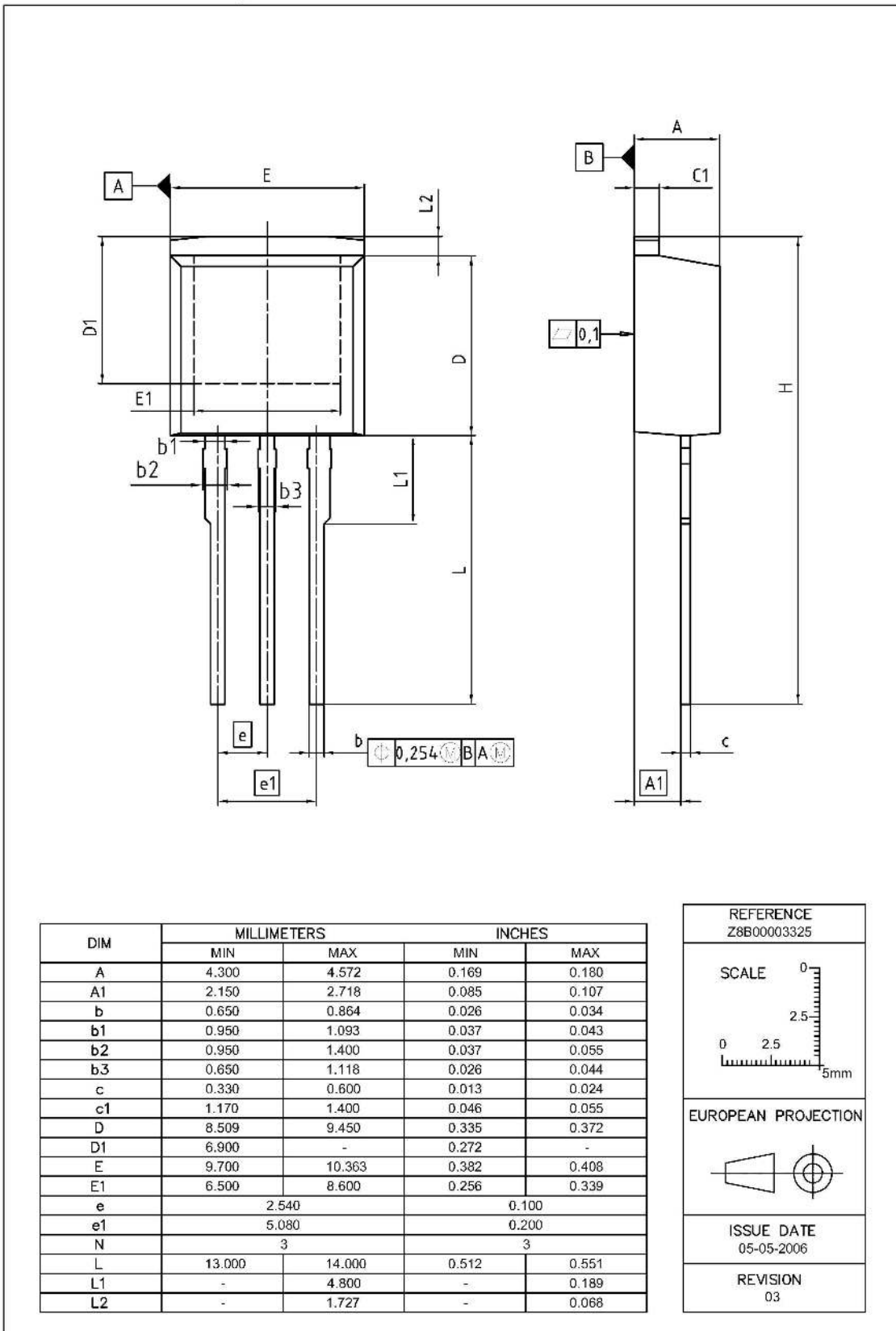

Figure 6 Outline PG-TO 262, dimensions in mm/inches



8 Appendix A

Table 23 Related Links

- **IFX Design Tools:**
<http://www.infineon.com/cms/en/product/promopages/designtools/index.html>
- **IFX CoolMOS Webpage:**
<http://www.infineon.com/cms/en/product/channel.html?channel=ff80808112ab681d0112ab6a628704d8>

Revision History

IPx65R660CFD

Revision: 2020-05-26, Rev. 2.7

Previous Revision

| Revision | Date | Subjects (major changes since last revision) |
|----------|------------|--|
| 2.1 | 2011-08-29 | update to CFD2 standard |
| 2.2 | 2011-09-15 | update pin naming |
| 2.3 | 2011-09-15 | update pin naming |
| 2.4 | 2011-09-15 | release of new pin naming |
| 2.5 | 2011-09-27 | update Igss test condition |
| 2.7 | 2020-05-26 | Update package outline |

Trademarks

All referenced product or service names and trademarks are the property of their respective owners.

We Listen to Your Comments

Any information within this document that you feel is wrong, unclear or missing at all? Your feedback will help us to continuously improve the quality of this document. Please send your proposal (including a reference to this document) to:

erratum@infineon.com

Published by

Infineon Technologies AG
81726 München, Germany
© 2020 Infineon Technologies AG
All Rights Reserved.

Legal Disclaimer

The information given in this document shall in no event be regarded as a guarantee of conditions or characteristics ("Beschaffenheitsgarantie").

With respect to any examples, hints or any typical values stated herein and/or any information regarding the application of the product, Infineon Technologies hereby disclaims any and all warranties and liabilities of any kind, including without limitation warranties of non-infringement of intellectual property rights of any third party.

In addition, any information given in this document is subject to customer's compliance with its obligations stated in this document and any applicable legal requirements, norms and standards concerning customer's products and any use of the product of Infineon Technologies in customer's applications.

The data contained in this document is exclusively intended for technically trained staff. It is the responsibility of customer's technical departments to evaluate the suitability of the product for the intended application and the completeness of the product information given in this document with respect to such application.

Information

For further information on technology, delivery terms and conditions and prices please contact your nearest Infineon Technologies Office (www.infineon.com).

Warnings

Due to technical requirements, components may contain dangerous substances. For information on the types in question, please contact the nearest Infineon Technologies Office.

The Infineon Technologies component described in this Data Sheet may be used in life-support devices or systems and/or automotive, aviation and aerospace applications or systems only with the express written approval of Infineon Technologies, if a failure of such components can reasonably be expected to cause the failure of that life-support, automotive, aviation and aerospace device or system or to affect the safety or effectiveness of that device or system. Life support devices or systems are intended to be implanted in the human body or to support and/or maintain and sustain and/or protect human life. If they fail, it is reasonable to assume that the health of the user or other persons may be endangered.