

REVISIONS

REV.	ECO NO.	DESCRIPTION	DATE	APPROVED
K	17-008568	ADDED MAX TO DIM 4.56 AND 5.06.	17JUNE2013	RS

BA104WA1  
3PST D.C. 200A CONTACTOR

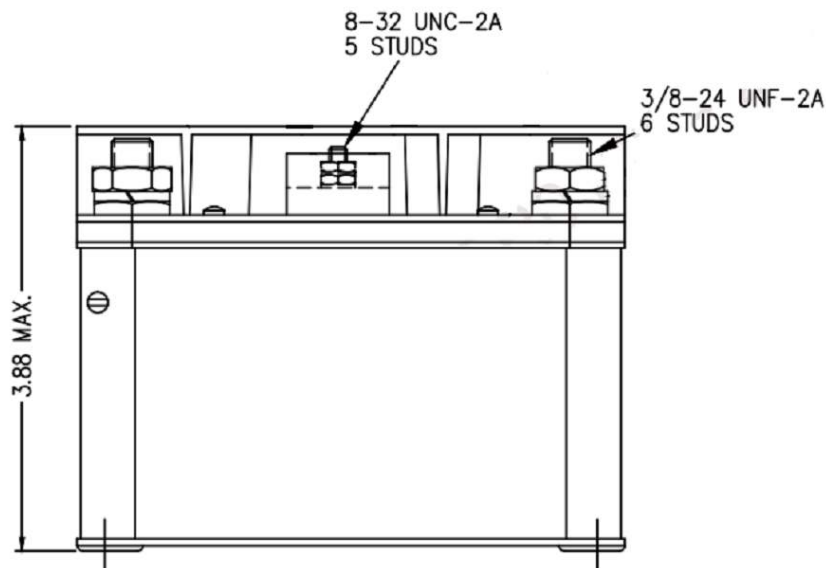
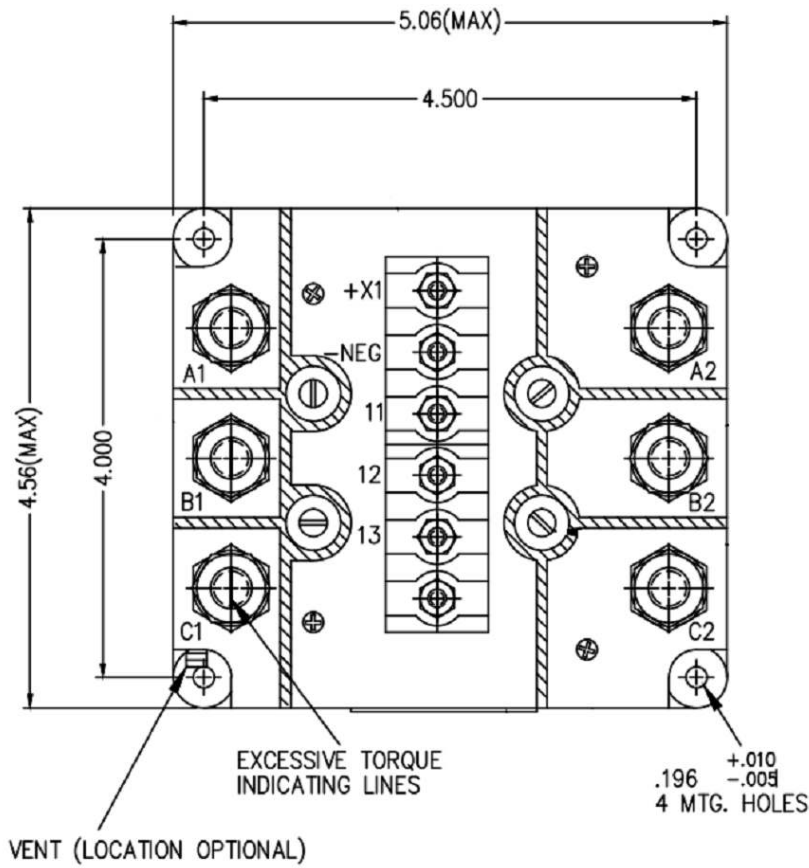

ALL DIMENSIONS ARE IN INCHES



TE CONNECTIVITY  
175 N. DIAMOND STREET MANSFIELD,  
OHIO 44902

TITLE CONTACTOR-200A, 200V, 400 CYCLE,  
3PST, D.C. OPERATED

TE P.N.  
1616007-1

DWG NO.  
BA104WA1

DS DATA SHEET

CAGE CODE  
74063

SCALE  
NONE

SHEET  
1 OF 2

REV  
K

GENERAL SPECIFICATION

<b>AUXILIARY CONTACT RATING</b>	
RATING AT 28 VDC OR 115 V 400HZ	
INRUSH	17 AMP
CARRY	10 AMP
BREAK	5 AMP
NOMINAL COIL VOLTAGE	28 VDC
PICKUP VOLTAGE	18 VOLTS MAX
DROPOUT VOLTAGE	7 VOLTS
COIL RESISTANCE (NOMINAL)	
PICKUP COIL AT 25°C	1.5 OHMS ±20%
HOLDING COIL AT 25°C	90 OHMS ±20%
CONTACTS	
ARRANGEMENT	3PST NO
RATING	200 AMP, 400 HZ
MAX WEIGHT	3 LBS 13 OZ
PROPOSED ALTERNATE RATING	100 AMP, 60 HZ
OVERLOAD INTERRUPTING CAPACITY	5X
MAX. AMBIENT TEMP	85°C

SCHEMATIC

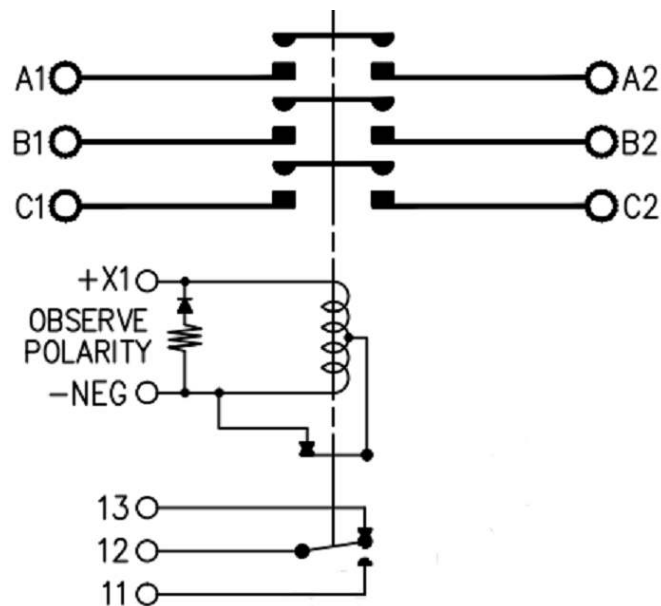

TE CONNECTIVITY  
175 N. DIAMOND STREET MANSFIELD,  
OHIO 44902

TITLE CONTACTOR-200A, 200V, 400 CYCLE,  
3PST, D.C. OPERATED

TE P.N.  
1616007-1

DWG NO.  
BA104WA1

THIRD ANGLE PROJECTION

THIS DRAWING PREPARED  
IN ACCORDANCE WITH  
ANSI/ASMEY14.5M-1982

CAGE CODE  
74063

SCALE  
NONE

SHEET  
2 OF 2

REV  
K