

DESCRIPTION

Demonstration circuit 438 is a triple phase single output synchronous buck converter featuring the LTC®3731CG. This circuit can be used for desktop computers and servers, notebook computers and other high output current DC/DC converters. The output voltage can be configured for either 2.5V or 1.8V and the maximum load current is 60A. The input voltage range of DC438 is 9V to 14V.

The LTC3731CG requires a separate supply for its internal control circuits and for its gate drivers. DC438 is populated with a 5V LT1761 linear regulator for this purpose. To obtain a higher

bias/gate drive supply voltage, the user can apply an external DC source to the “+5V” terminal on DC438. The maximum voltage for this input is 7.0V.

DC438 also features an on-board high di/dt dynamic load circuit to measure the load step response. Refer to the “Dynamic Load Testing” section for operating instructions.

Design files for this circuit board are available. Call the LTC factory.

LTC is a trademark of Linear Technology Corporation

Table 1. Performance Summary

PARAMETER	CONDITION	VALUE
Minimum Input Voltage		9V
Maximum Input Voltage		14V
V _{OUT}	V _{IN} = 9V to 14V, I _{OUT} = 0A to 60A	2.5V ± 3% 1.8V ± 3%
Airflow	100% load	≥100 LFM

QUICK START PROCEDURE

Demonstration circuit 438 is easy to set up to evaluate the performance of the LTC3731CG. Refer to Figure 1 for proper measurement equipment setup and follow the procedure below:

1. With power off, connect the input voltage source and the load. The input cables should be sized for 20A and the load cables should be sized for 60A.
2. If an external bias supply is connected to “+5V”, then the “5V SELECT” jumper should be in the “EXT” position. The external bias supply should be able to supply at least 100mA.
3. The jumpers should be in their default positions as shown in Figure 1.
4. If a constant current load is used, preset the load current to about 5A or less before applying power to the input. Otherwise, the foldback current limit function of the LTC3731 will be triggered during startup.
5. Apply power to the input and set the input voltage to 12V. The output voltage should be 2.5V ± 3%. Increase the load to 60A. The output voltage should still be within regulation.
6. Keep the input voltage at 12.0V and the load at 60A. Measure the DC input current. It should be less than 15.2A.
7. Remove input power from the converter. Set the voltage to 1.8V using jumper JP3. Apply 12V to the input and 60A to the output. The voltage should be 1.8V ± 3%.
8. For operation at 100% load and room temperature ambient, use 100 LFM airflow or greater.

QUICK START GUIDE FOR DEMONSTRATION CIRCUIT 438

TRIPLE PHASE, SINGLE OUTPUT STEP-DOWN CONVERTER

9. Adjust the input voltage and load current to the desired levels within their limits and observe the regulation, output ripple, load step response, efficiency and other parameters.

NOTE: The BNC connectors labeled “VOUT+” and “LOAD STEP” can be used to monitor the output voltage and load step waveforms, respectively, on an oscilloscope.

DYNAMIC LOAD TESTING

DC438 is populated with a high di/dt dynamic load circuit that is capable of applying a 0A to 60A load step to the output. The lower level of the step is fixed at 0A. To test this circuit, follow the instructions below:

1) Put both the “DLC” jumper and the “DLC BIAS” jumper in the “ON” position.

- 2) Turn-on the converter and set the external load to the low level of the load step.
- 3) Adjust potentiometers R38, R34 and R33 to set the height, up slope and down slope of the load step respectively.
- 4) Monitor the load step current and output voltage. For the load step current, $5\text{mV} = 1\text{A}$.

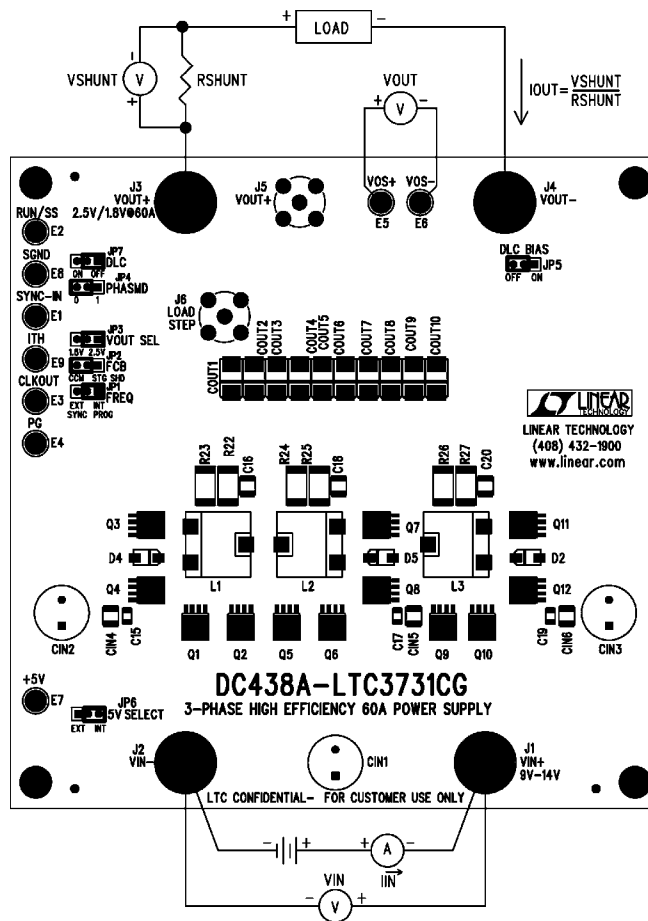
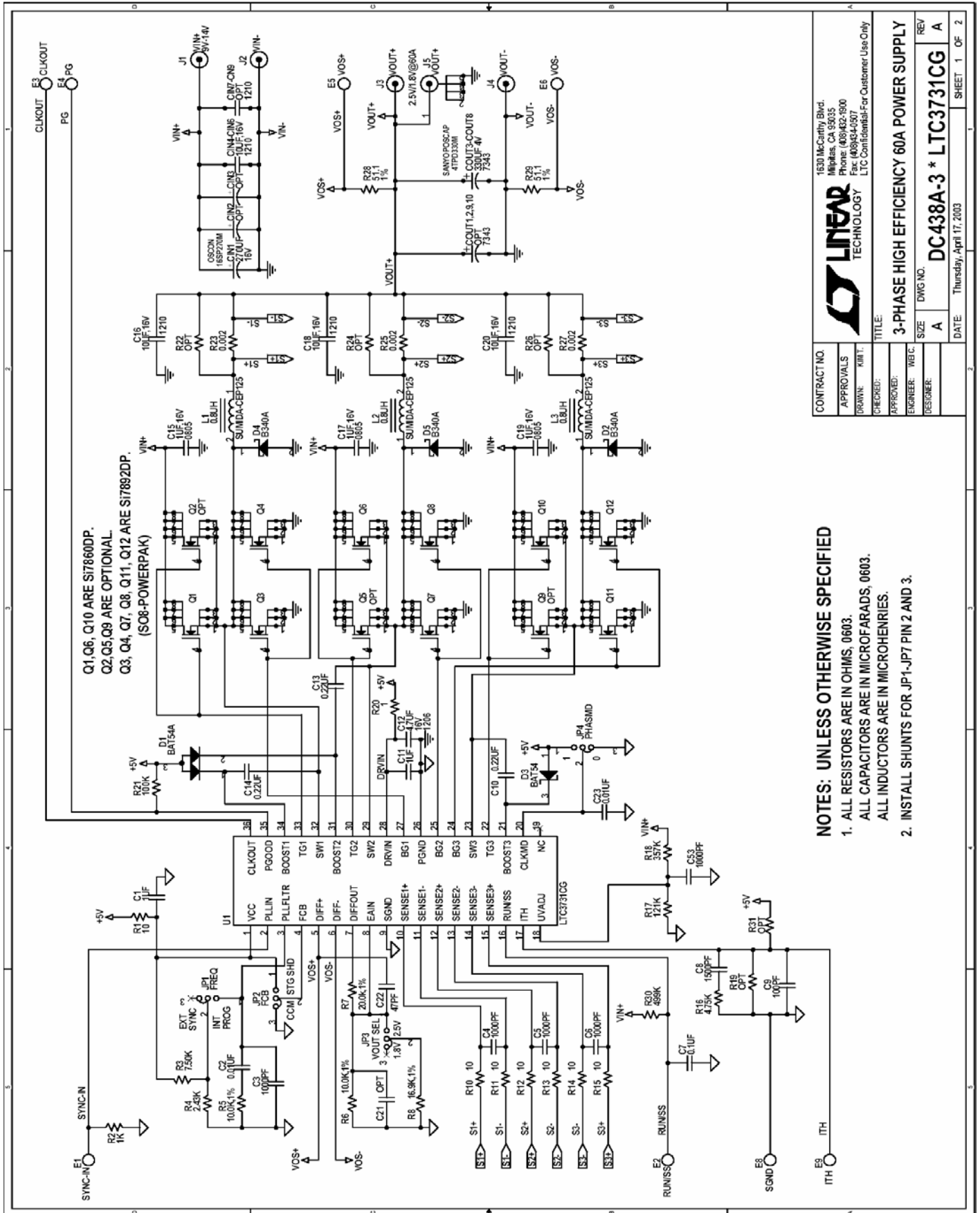

Figure 1. Proper Measurement Equipment Setup

QUICK START GUIDE FOR DEMONSTRATION CIRCUIT 438

TRIPLE PHASE, SINGLE OUTPUT STEP-DOWN CONVERTER



NOTES: UNLESS OTHERWISE SPECIFIED

1. ALL RESISTORS ARE IN OHMS, 0603.
2. ALL CAPACITORS ARE IN MICROFARADS, 0603.
3. ALL INDUCTORS ARE IN MICROHENRIES.
4. INSTALL SHUNTS FOR JP1-JP7 PIN 2 AND 3.

CONTRACT NO.	1630 McCarthy Blvd. Milpitas, CA 95035 Phone: (408)432-1900 Fax: (408)434-9507 LTC Confidential-For Customer Use Only
APPROVALS	LINEAR TECHNOLOGY
DRAWN: K.M.T.	TITLE: 3-PHASE HIGH EFFICIENCY 60A POWER SUPPLY
CHECKED:	SIZE: A
APPROVED:	DWG. NO. DC438A-3 * LTC3710G
ENGINEER: T.M.C.	DATE: Thursday, April 17, 2003
DESIGNER:	REV: A
	SHEET 1 OF 2

QUICK START GUIDE FOR DEMONSTRATION CIRCUIT 438

TRIPLE PHASE, SINGLE OUTPUT STEP-DOWN CONVERTER

DYNAMIC LOAD CIRCUIT

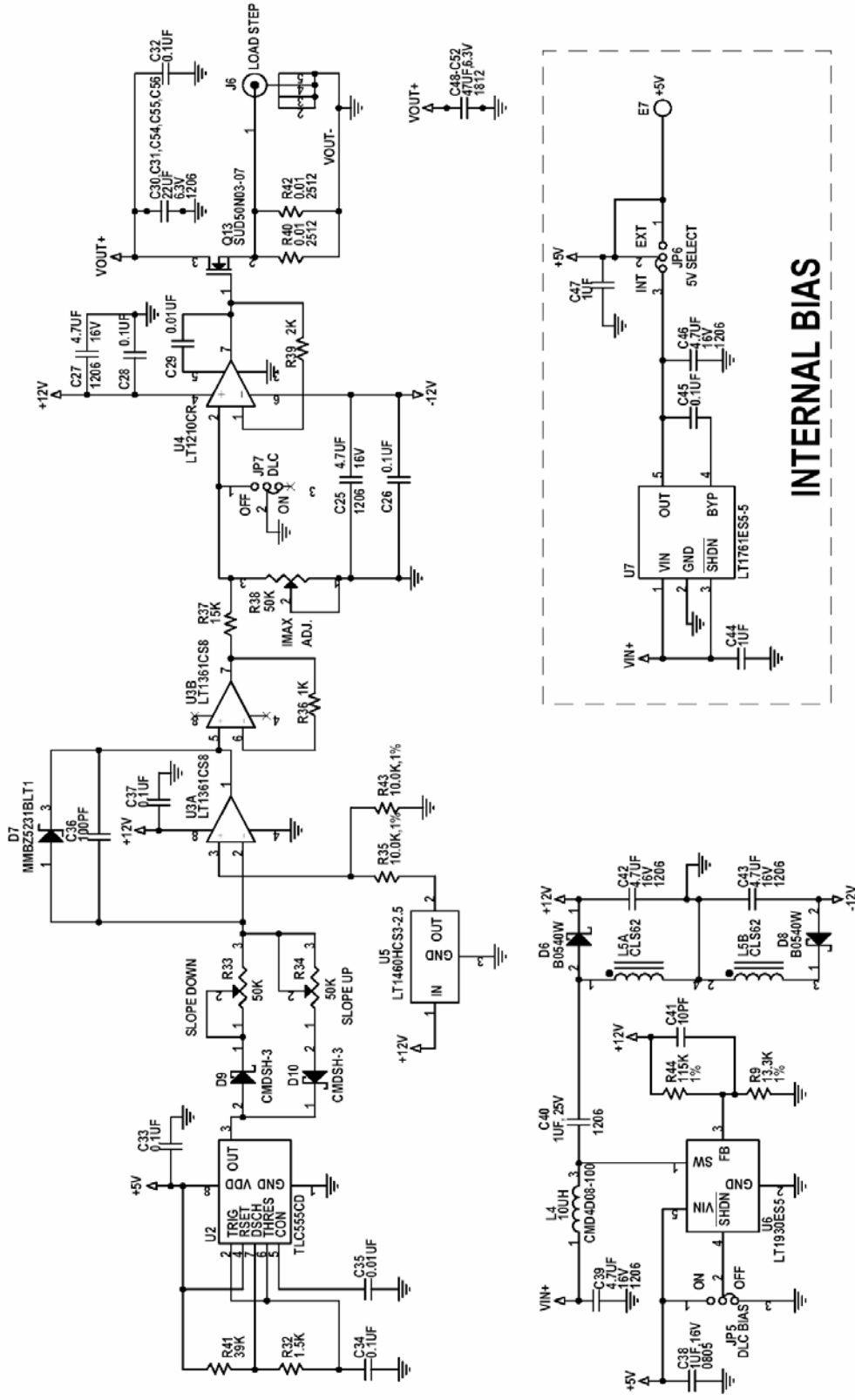

INTERNAL BIAS

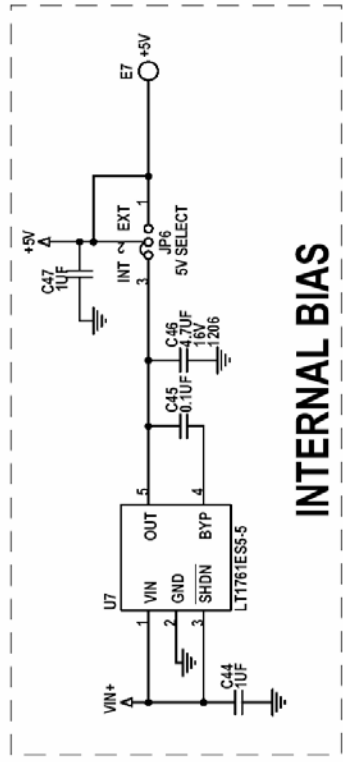

CONTRACT NO.		1630 McCarthy Blvd. Milpitas, CA 95035 Phone: (408)432-1900 Fax: (408)434-0507 LTC Confidential-For Customer Use Only	
APPROVALS		 LINEAR TECHNOLOGY	
DRAWN: RMT.		TITLE: 3-PHASE HIGH EFFICIENCY 60A POWER SUPPLY	
CHECKED:		SIZE: A	
APPROVED:		DWG NO.: DC438A-3 * LTC3731CG	
ENGINEER: WETC.		DATE: Thursday, April 17, 2003	
DESIGNER:		REV: A	
		SHEET 2 OF 2	