

# CES-SRG-BK-2ASI-LL - Cable sleeve

1410055

<https://www.phoenixcontact.com/us/products/1410055>

Please be informed that the data shown in this PDF document is generated from our online catalog. Please find the complete data in the user documentation. Our general terms of use for downloads are valid.



Cable sleeve, small, no. of conductors: 2, type: AS-i cable (Left Left), slotted, material: NBR, color: black, length: 29.5 mm, width: 19.5 mm, height: 17 mm

## Commercial data

Item number	1410055
Packing unit	1 pc
Minimum order quantity	10 pc
Sales key	BF67
Product key	BF7CCX
Catalog page	Page 679 (C-2-2019)
GTIN	4046356776202
Weight per piece (including packing)	7.84 g
Weight per piece (excluding packing)	7.84 g
Customs tariff number	40169997
Country of origin	TW

# CES-SRG-BK-2ASI-LL - Cable sleeve

1410055

<https://www.phoenixcontact.com/us/products/1410055>

## Technical data

### Product properties

Product type	Cable sleeve
No. of conductors	2

### Dimensions

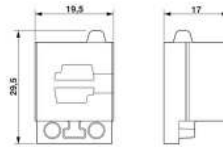
Dimensional drawing	
Width	19.5 mm
Height	17 mm
Length	29.5 mm

### Material specifications

Material	NBR
----------	-----

### Characteristics

Conductor sealing range	AS-i cable
Seal size	small
Design, Format	AS-i cable
Design, Cable seal	slotted

### Environmental and real-life conditions

#### Ambient conditions

Degree of protection	IP54
Ambient temperature (operation)	-40 °C ... 125 °C (static)

# CES-SRG-BK-2ASI-LL - Cable sleeve



1410055

<https://www.phoenixcontact.com/us/products/1410055>

## Classifications

### ECLASS

ECLASS-11.0	27144425
ECLASS-12.0	27144425
ECLASS-13.0	27144425

### ETIM

ETIM 8.0	EC000451
----------	----------

### UNSPSC

UNSPSC 21.0	39121400
-------------	----------

# CES-SRG-BK-2ASI-LL - Cable sleeve



1410055

<https://www.phoenixcontact.com/us/products/1410055>

## Environmental product compliance

China RoHS	Environmentally friendly use period: unlimited = EFUP-e No hazardous substances above threshold values
------------	---

Phoenix Contact 2023 © - all rights reserved  
<https://www.phoenixcontact.com>

Phoenix Contact USA  
586 Fulling Mill Road  
Middletown, PA 17057, United States  
(+717) 944-1300  
[info@phoenixcon.com](mailto:info@phoenixcon.com)