

Evaluating the ADPD6000 Multimodal Sensor Front End

FEATURES

- ▶ Board supports [ADPD6000](#) population
- ▶ 4 separately driven LEDs included: 1 green LED at the center, 1 red LED, and 2 infrared LEDs
- ▶ Four channels of PD input: two channels with single PD, and two channels with double PD
- ▶ Works with the VSM Client evaluation software allowing
 - ▶ Time domain graphing and logging
 - ▶ Selection of supported functions, including PPG, BIA, and ECG
 - ▶ Real-time data display with the various combinations of the functions

EVALUATION KIT CONTENTS

- ▶ EVAL-ADPD6000Z evaluation board
- ▶ [EVAL-VSMUCZ](#) microcontroller board

ADDITIONAL EQUIPMENT NEEDED

- ▶ USB to Type-C cable
- ▶ 3.7 V battery
- ▶ Electrode board
- ▶ Soft cable to connect EVAL-ADPD6000Z and EVAL-VSMUCZ
- ▶ Wrist strap

EVALUATION BOARD PHOTOGRAPH

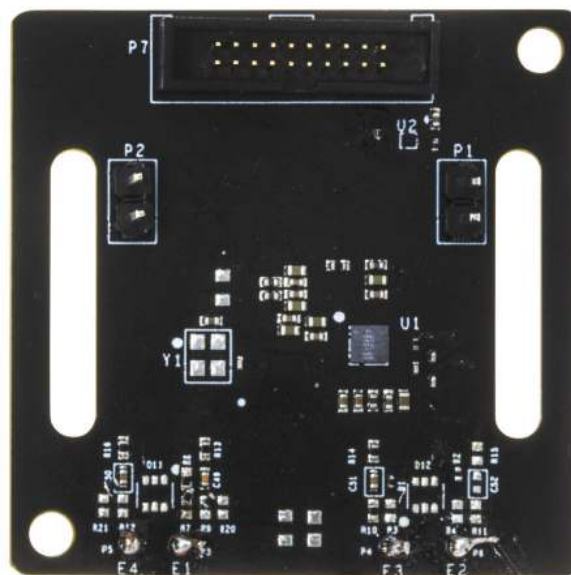

Figure 1. EVAL-ADPD6000Z

ONLINE RESOURCES

- ▶ [ADPD6000 data sheet](#)
- ▶ [VSM Client software](#) (available on [EVAL-ADPD6000](#) product page)

GENERAL DESCRIPTION

This user guide describes the operation of the EVAL-ADPD6000Z demonstration kit, which is an evaluation module for the ADPD6000.

The ADPD6000 is a fully integrated analog front end (AFE) for wearable vital signal monitoring (VSM) devices. The key functions of the ADPD6000 include photoplethysmography (PPG), electrocardiography (ECG), and body impedance analysis (BIA).

The demonstration kit includes both software and hardware. The EVAL-ADPD6000Z can evaluate the AFE feature and verify the system design based on the AFE. According to the requirements of the application, the user can use a cable connection or Bluetooth connection to establish communication between the PC and the EVAL-ADPD6000Z.

This user guide also describes the example configuration of the different functions of the ADPD6000.

For full details on the ADPD6000, see the [ADPD6000 data sheet](#), which must be consulted in conjunction with this user guide when using the EVAL-ADPD6000Z.

TABLE OF CONTENTS

Features.....	1	Power On–Bluetooth Connection.....	6
Evaluation Kit Contents.....	1	Add Device via Bluetooth.....	6
Additional Equipment Needed.....	1	VSM Client	8
Online Resources.....	1	Find the Device On VSM Client	8
General Description.....	1	Configure the Device.....	10
Evaluation Board Photograph.....	1	Receive the Data.....	11
Preparation and Setup.....	3	Human Measurement.....	13
EVAL-ADPD6000Z Components.....	3	PPG Measurement.....	13
PCB Connection.....	3	ECG Measurement.....	13
Software Installation.....	5	BIA Measurement.....	14
Power on the System.....	6	Evaluation Board Schematics and Artwork.....	15
Power On–Cable Connection.....	6	Notes.....	20

REVISION HISTORY

4/2022—Revision 0: Initial Version

PREPARATION AND SETUP

EVAL-ADPD6000Z COMPONENTS

Figure 2 shows the components needed for evaluation.

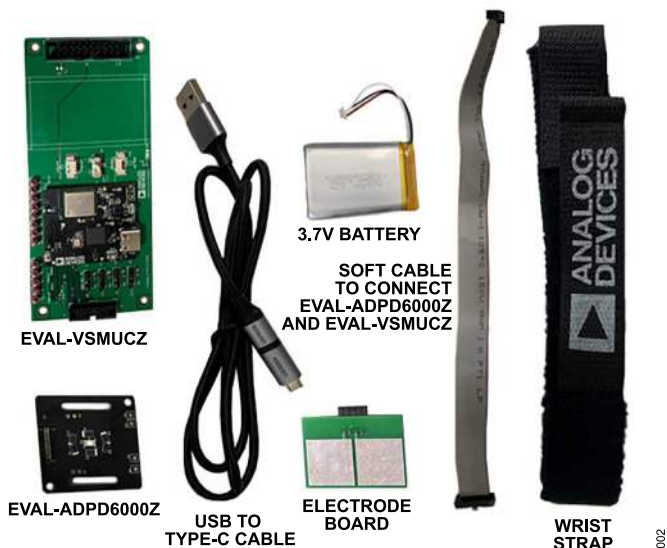

Figure 2. EVAL-ADPD6000Z Demonstration Kit Components

PCB CONNECTION

Take the following steps to establish the printed circuit board (PCB) connection:

1. Connect the battery to the connector on the EVAL-VSMUCZ (see Figure 3). Ensure that the S1 switch is off.

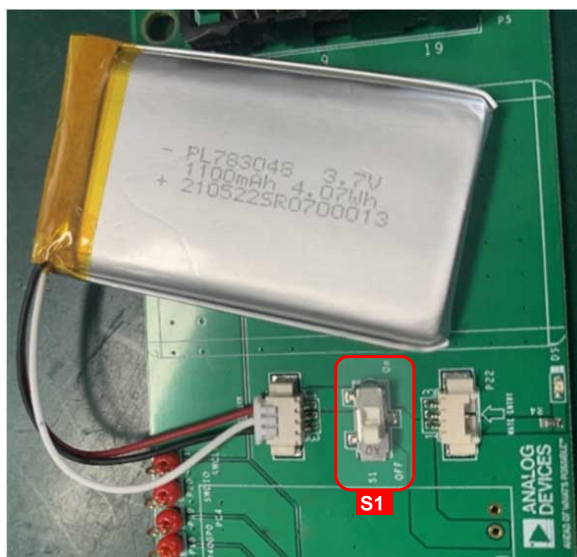

Figure 3. Battery Connected to EVAL-VSMUCZ

2. Connect the EVAL-VSMUCZ to the EVAL-ADPD6000Z (see Figure 4 and Figure 5). Ensure the EVAL-VSMUCZ and EVAL-ADPD6000Z have the same number of pins, and that the pin numbers match.

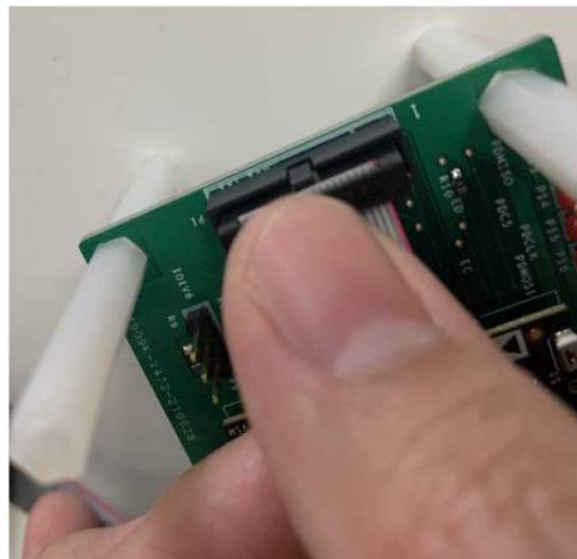

Figure 4. EVAL-VSMUCZ Connection



Figure 5. EVAL-ADPD6000 Connection

3. For ECG or BIA measurement, connect the EVAL-ADPD6000Z to the electrodes on the electrode board as follows:
 - ▶ For ECG measurement, connect P3 to Electrode 1, P4 to Electrode 2, and P6 to Electrode 3. Leave Electrode 4 unconnected (see Figure 6).
 - ▶ For BIA measurement, connect P3 to Electrode 1, P4 to Electrode 2, P6 to Electrode 3, and P5 to Electrode 4 (see Figure 7).

Note that the BIA connection can also be used for ECG measurement.

PREPARATION AND SETUP

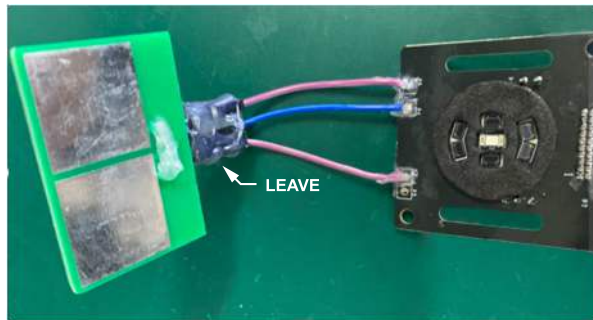

Figure 6. ECG Connection

006



Figure 7. BIA Connection

007

Figure 8 shows the EVAL-ADPD6000Z kit connection after setup.

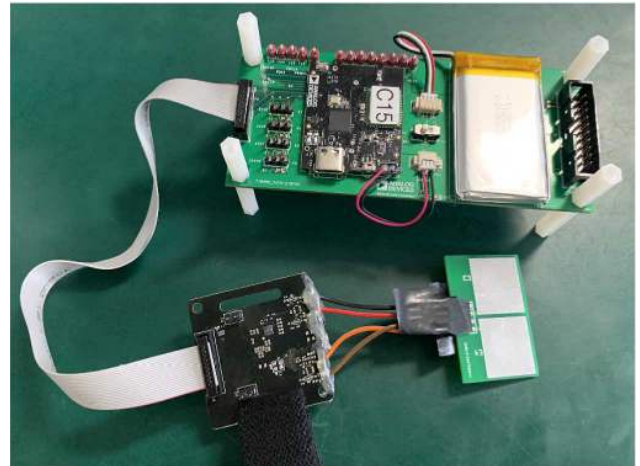

Figure 8. Demonstration Kit After Setup

008

SOFTWARE INSTALLATION

The VSM Client software is the graphical user interface (GUI) used for the EVAL-ADPD6000Z demonstration kit. The VSM Client software is available on the EVAL-ADPD6000Z product page.

Take the following steps to install VSM Client:

1. Download and launch the VSM Client installer.
2. Read the software license agreement and click **I Agree** (see [Figure 9](#)).

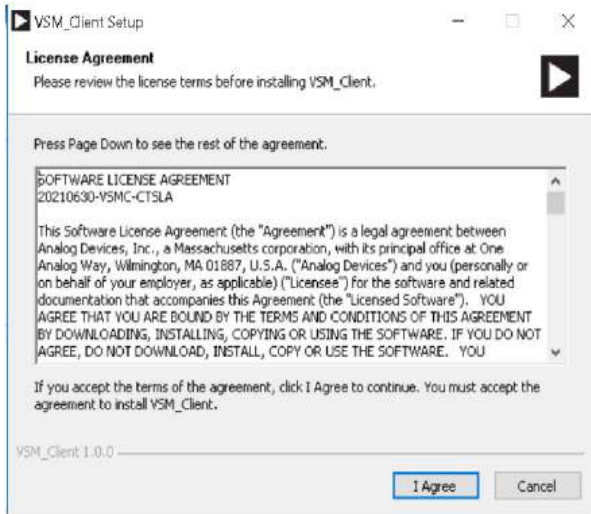

Figure 9. License Agreement

3. Select **Only for me** and click **Next >** (see [Figure 10](#)). Do not select **Anyone who uses this computer (all users)**, as this option can cause the installation to suspend or fail.

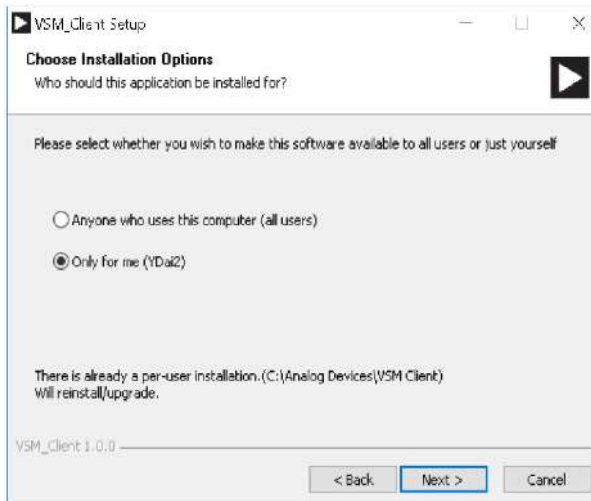

Figure 10. Choose Installation Options

4. Click **Browse...** to choose the installation location and then click **Next >** (see [Figure 11](#)).

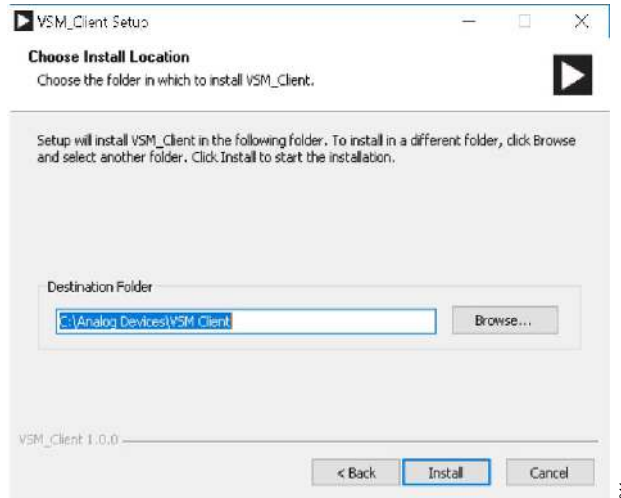

Figure 11. Choose Installation Location

5. When the installation is complete, click **Finish** to complete the installation process (see [Figure 12](#)).

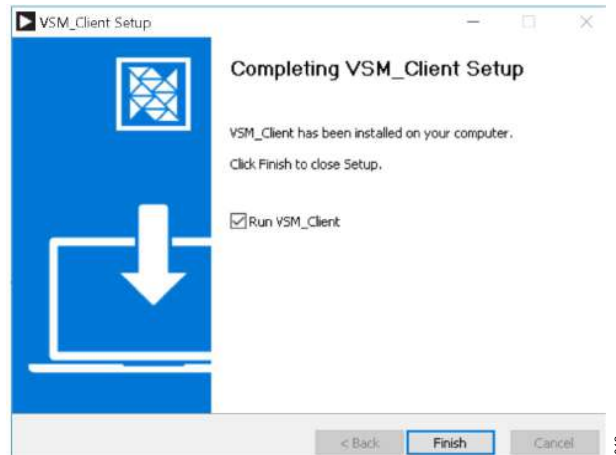

Figure 12. Installation Complete

POWER ON THE SYSTEM

After preparing the hardware and installing the software, the EVAL-ADPD6000Z is ready to power on.

POWER ON–CABLE CONNECTION

Connect the USB to Type-C cable from the PC to J5 on the EVAL-VSMUCZ to power on the EVAL-VSMUCZ automatically. The two indicator lights on the EVAL-VSMUCZ (DS1 and DS4) turn on. If the S1 switch labeled in Figure 13 is set to on, the battery is charged by the PC. Figure 13 shows the cable connection.

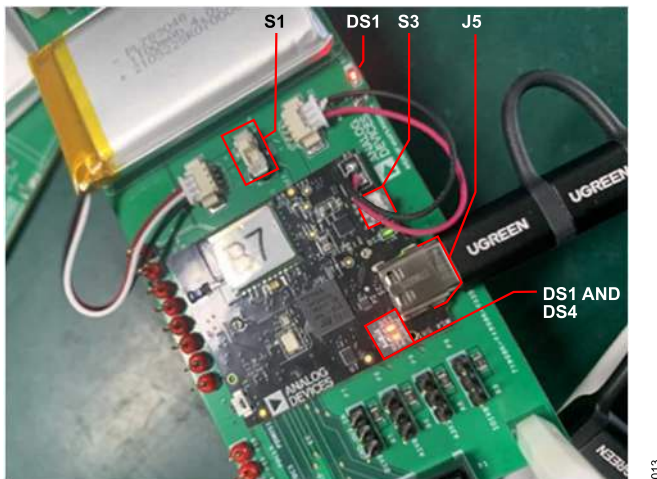

Figure 13. Cable Connection

POWER ON–BLUETOOTH CONNECTION

Take the following steps to power on the system without the USB cable:

1. On the EVAL-VSMUCZ, set the S1 switch labeled in Figure 13 to on. The standalone DS1 indicator LED labeled in Figure 13 turns on.
2. Press (for about two seconds) the S3 button on the EVAL-VSMUCZ to power on the system. The two indicator lights on the EVAL-VSMUCZ (DS1 and DS4) turn on.

ADD DEVICE VIA BLUETOOTH

Take the following steps to add the EVAL-VSMUCZ via Bluetooth (these steps are shown using Windows® 10):

1. Click the **Bluetooth Devices** icon in the system tray and select **Add a Bluetooth Device** (see Figure 14).

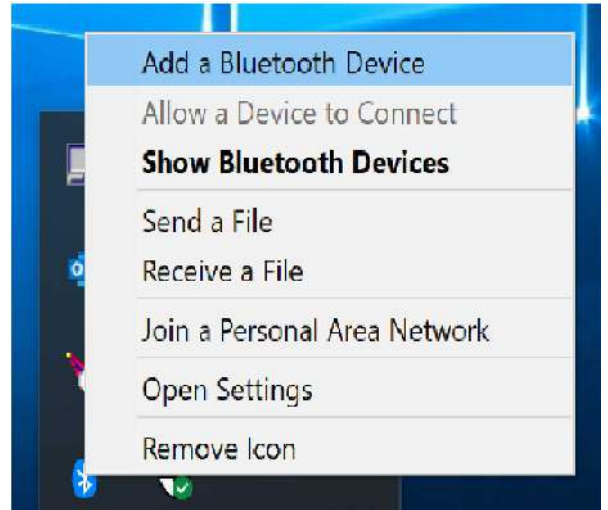

Figure 14. Add a Bluetooth Device

2. The **Settings** window opens (see Figure 15). Under **Bluetooth & other devices**, click **Add Bluetooth or other device**.

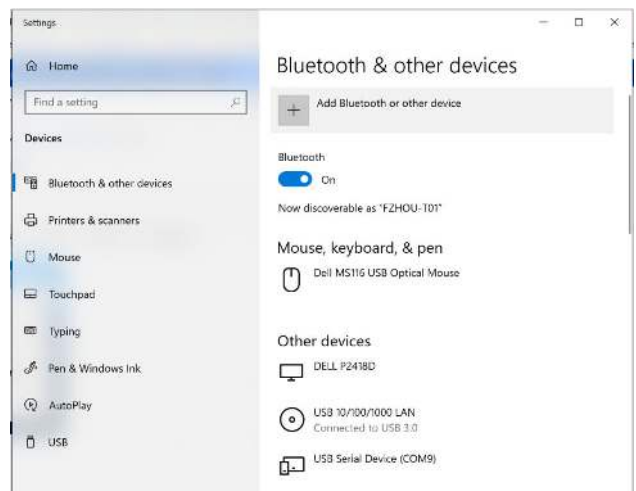

Figure 15. Add Bluetooth Device from Settings Window

3. The **Add a device** window opens (see Figure 16). Select **Bluetooth**.

POWER ON THE SYSTEM

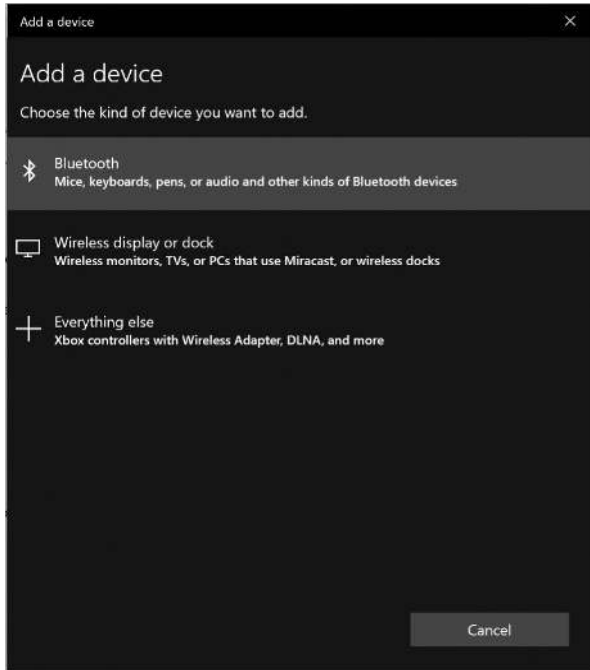

Figure 16. Choose Bluetooth Device Type

- 4. Select the EVAL-VSMUCZ from the list of devices (in this example, Figure 17 shows the device as B8-7425A2). The device is now connected (see Figure 18).

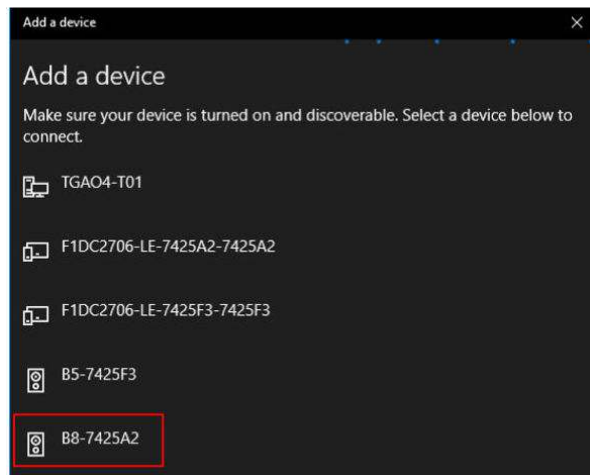

Figure 17. Select EVAL-VSMUCZ

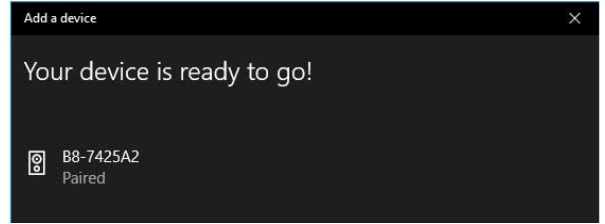

Figure 18. Device Connected

After adding the EVAL-VSMUCZ, two Bluetooth serial ports appear in the Device Manager window: Standard Serial over Bluetooth link (COM10) and Standard Serial over Bluetooth link (COM11) (see Figure 19). The user selects one of these two ports in the VSM Client software.

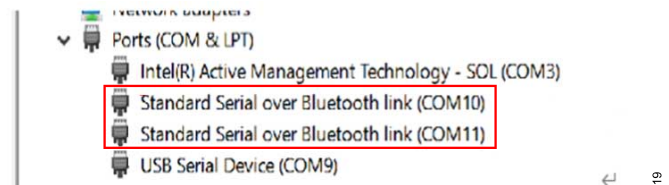

Figure 19. Device Manager

VSM CLIENT

FIND THE DEVICE ON VSM CLIENT

Take the following steps to find the device on the VSM Client software:

1. After installing VSM Client, power on the EVAL-ADPD6000Z and launch VSM Client.
2. Click **Click to connect** in the start interface of VSM Client (see Figure 20).

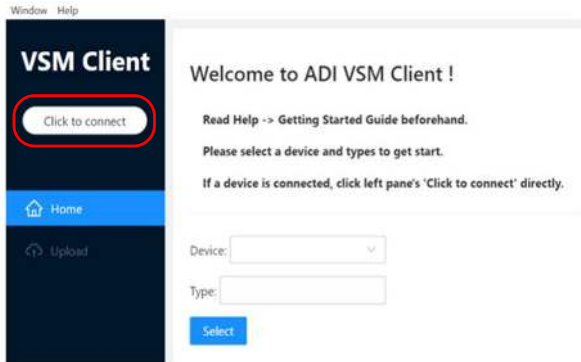

Figure 20. Start Interface of VSM Client

3. In the **Hardware Connection** pane, select the communication (COM) port according to the connection method, as follows:
 - ▶ If using a Bluetooth connection, two ports are available. In the example shown in Figure 21, these ports are **COM50 Microsoft BTHENUM** and **COM58 Microsoft BTHENUM**. Select one of the two ports. If the following steps cannot be completed successfully with the selected port, select a different port.
 - ▶ If using a cable connection, only one port is available (see Figure 22). In the example shown in Figure 22, the port is **COM11 Microsoft USB**.

The COM serial port numbers shown are examples only. Refer to the **Device Manager** for the COM serial port numbers.



Figure 21. Bluetooth Connection COM Ports



Figure 22. Cable Connection COM Port

4. Toggle the connection switch to **Connect** (see Figure 23). When connected, a **Success to connect target!** pop-up appears at the top of the VSM Client window (see Figure 24), and

the **Click to connect** button changes to display **Connected 6000**. To disconnect the device, toggle the connection switch to **Disconnect**. The following pop-up messages can appear if the connection is unsuccessful:

- ▶ **Failed to connect target: undefined. Please try to reconnect.** If this pop-up appears (see Figure 25), select another COM port and reconnect.
- ▶ **Fail to get firmware version!** If this pop-up appears (see Figure 26), the firmware version may not match the software version. Update the firmware in the kit. For details on updating the firmware, see the EVAL-ADPD6000Z product page.

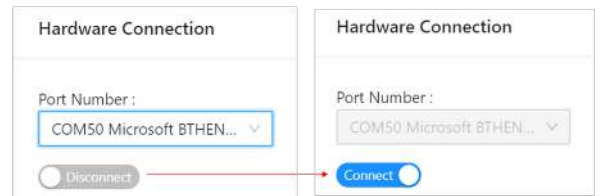

Figure 23. Toggle Connection Switch

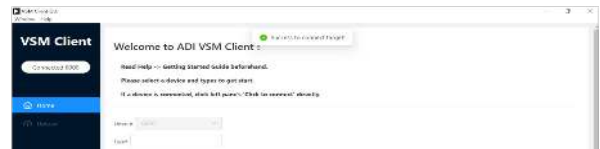

Figure 24. Connection Successful

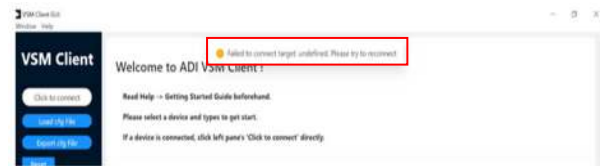

Figure 25. Failed to Connect Target Error



Figure 26. Failed to Get Firmware Version Error

5. From the **Type** dropdown menu, select one of three functions: **ECG**, **PPG**, or **BIOZ** (see Figure 27). Click **Select** to enter the configuration interface.

VSM CLIENT

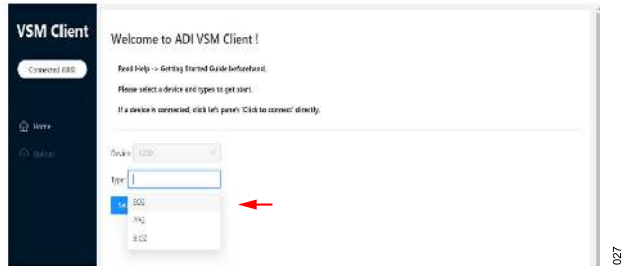

Figure 27. Select Function

VSM CLIENT

CONFIGURE THE DEVICE

Take the following steps to configure the device:

1. Click **Load cfg File** in the configuration interface of VSM Client to load a basic configuration file (see Figure 28). To export the current configuration file, click **Export cfg File** to save the script in the configuration file folder (see Figure 30). To change the loaded .dcfg file, click **Reset** before continuing.

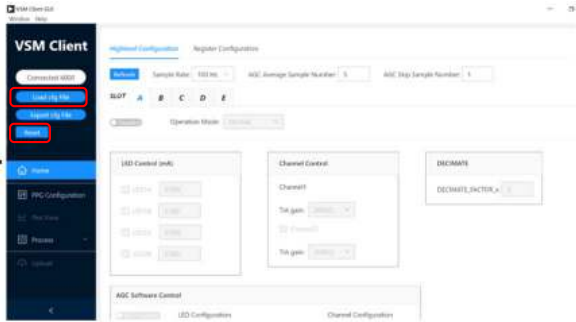

Figure 28. Configuration Interface

2. Click **Click/Drag a .dcfg file to load** to open the .dcfg file in the **Load Configuration** window (see Figure 29). According to the application or measurement conditions, the user can choose the following initial configurations from the **C:\Analog Devices\VSM Client\VSM_Client\Cfg\ADPD6000** location:
 - ▶ ADPD6000_BIOZ_slotABCDEF_MS6_Testing: BIA magnitude and phase measurement
 - ▶ ADPD6000_ECG_Testing: ECG channel signal measurement
 - ▶ ADPD6000_PPG_Testing_slotA_Peak_SNR_one_led: PPG peak signal-to-noise (SNR) test using LED1A
 - ▶ ADPD6000_PPG_Testing_slotA_Peak_SNR_two_led: PPG peak SNR test using LED1A and LED2A
 - ▶ ADPD6000_PPG_Testing_slotA_SNR_85dB: PPG 85 dB SNR test using LED2A
 - ▶ ADPD6000_PPG_Testing_slotA_SNR_95dB: PPG 95dB SNR test using LED1A

The configuration files in the configuration file folder may differ from those shown in Figure 30.



Figure 29. Choose Configuration File

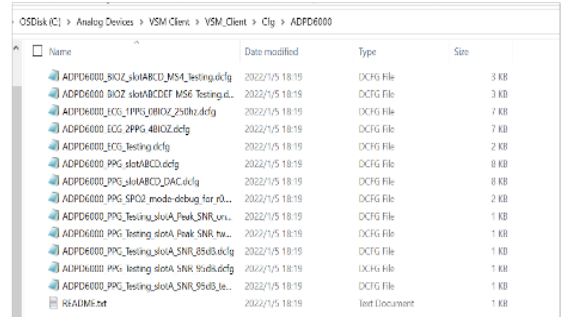

Figure 30. Configuration File Folder

3. Click **Load** (see Figure 31) to load the configuration file.

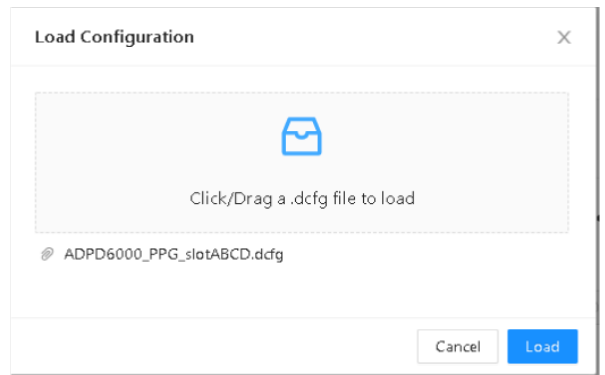

Figure 31. Load Configuration

4. After loading the configuration file, the **Highlevel Configuration** tab shows the current device data (see Figure 32). This tab shows the most used controls, which can be configured. To reset the data, click **Reset**.

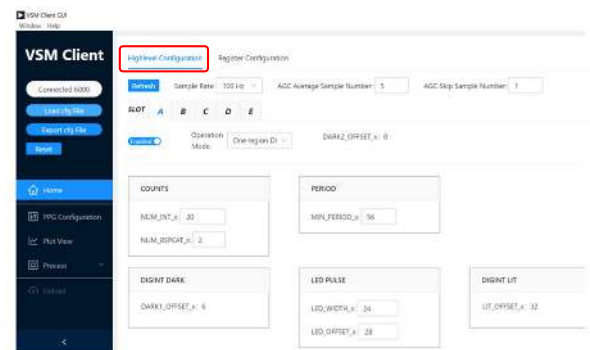

Figure 32. Highlevel Configuration Tab

5. To read or write an individual register, click the **Register Configuration** tab. To check a register, enter the address in the **Register Address** field and click **Read** (see Figure 33). To change a register, enter the value in the **Register Value** field and click **Write** (see Figure 34). See the **ADPD6000** data sheet for the detailed values of the registers.

VSM CLIENT



Figure 33. Reading Individual Register



Figure 34. Writing Individual Register

6. If a **Fail to read register** or **Fail to write register** pop-up appears (see Figure 35), check whether the device is disconnected or broken.



Figure 35. Error Message when Configuring Individual Register

RECEIVE THE DATA

Take the following steps to receive data from the FIFO after running the EVAL-ADPD6000Z:

1. After connecting the device and loading the configuration file, click **Plot View** to view the **Plot View** interface and click the run button (see Figure 36).

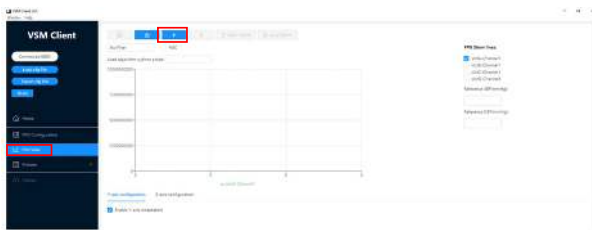

Figure 36. Plot View Interface

2. The waveform appears in the **Plot View** page (see Figure 37). If the waveform is out of scale, select the **Enable Y-axis Adaptation** check box to adapt the vertical scale of the plot to the waveform scale.

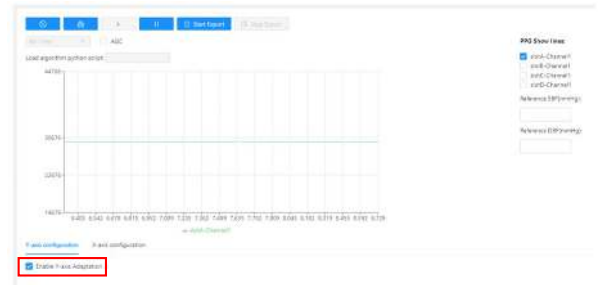

Figure 37. Waveform

3. To adjust the dots number on the x-axis, select a value from the **X-axis dots number** dropdown menu (see Figure 38).



Figure 38. Change X-Axis Dots Number

4. To view the waveforms of different slots and channels, select the check boxes under **PPG Show lines** (see Figure 39). Figure 39 shows **slotA-Channel1** and **slotB-Channel1** selected.

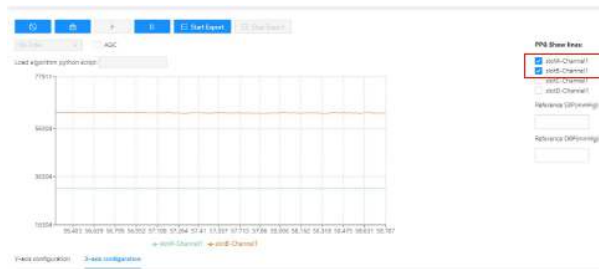

Figure 39. Select Slot and Channel Waveforms

5. Click **Start Export** to begin exporting the data received (see Figure 40), and click **Stop Export** to stop exporting the data locally (see Figure 41). The exported data is saved in an .xlsx file. Before clicking **Stop Export**, clear the **Enable Y-axis Adaptation** check box. If this check box is selected, the data may fail to save. If the export is successful, a **Success to export data** pop-up appears (see Figure 42) noting the location of the .xlsx file as follows: **C:\Analog Devices\VSM Client\VSM_Client\Export**. In the **Export** folder, the file name notes the date, time, and corresponding function of the export (see Figure 43).

VSM CLIENT



Figure 40. Start Export

040

- Click the **Stop Data Plot** button to clear the plot (see Figure 45).

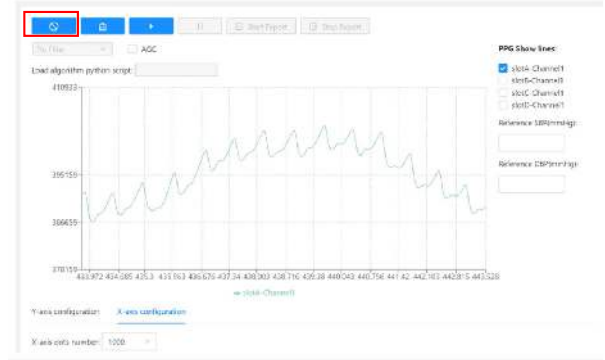

Figure 45. Clear Plot Data

045

- On the EVAL-ADPD6000Z, place a white reflective card before the LED and PD pair to get a dc waveform (see Figure 46) that can be used to measure the performance of the system, such as SNR, noise, and ambient light rejection (ALR).



Figure 41. Stop Export

041



Figure 46. DC Waveform

046

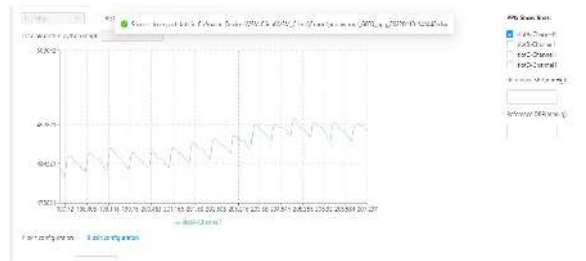

Figure 42. Export Successful

042

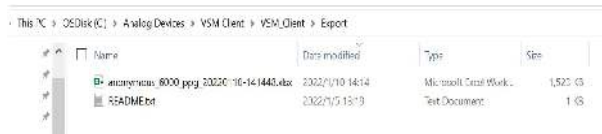

Figure 43. Export Folder

043

- Click the pause button to stop receiving data (see Figure 44).



Figure 44. Stop Receiving Data

044

HUMAN MEASUREMENT

The [PPG Measurement](#), [ECG Measurement](#), and [BIA Measurement](#) sections provide a brief guide on using the EVAL-ADPD6000Z for human measurement. The example waveforms in these sections are for reference only and do not illustrate the performance of the system. The detailed characteristics relate to the configuration and measurement environment.

PPG MEASUREMENT

The user can place a finger on the light insulation cushion on the LED and PD pair of the EVAL-ADPD6000Z to get a detailed PPG signal with the heart rate (see [Figure 47](#)). The light insulation cushion avoids the light that passes from the LED to the PD.

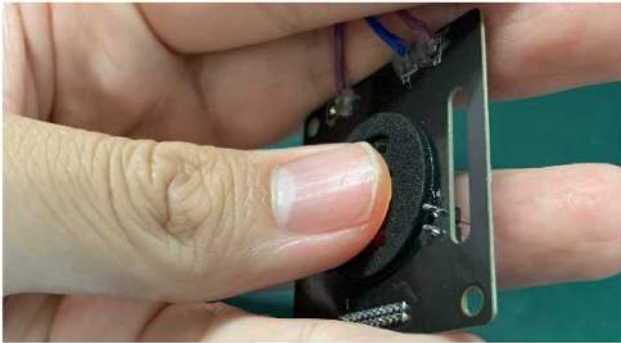

Figure 47. PPG Measurement

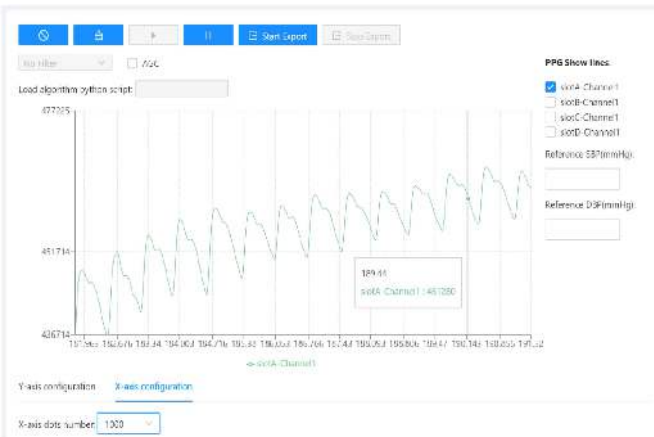

Figure 48. PPG Measurement Example Waveform with Green LED and 100 Hz Output Data Rate (ODR)

The user can also place the EVAL-ADPD6000Z on the wrist (PD and LED side against the skin) to simulate the watch type measurement (see [Figure 49](#)).



Figure 49. Watch Type Measurement

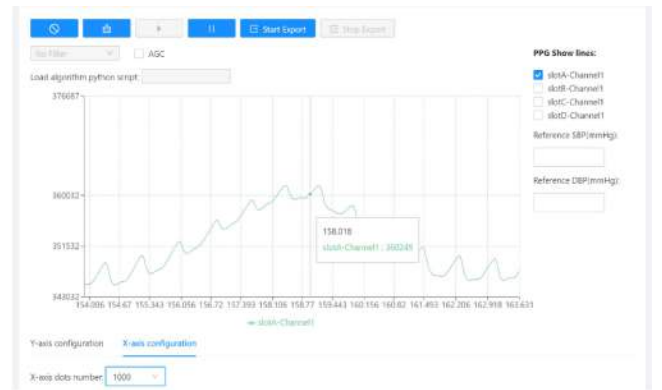

Figure 50. Watch Type Measurement Example Waveform with Green LED and 100 Hz ODR

ECG MEASUREMENT

For ECG measurement, connect an electrode board as shown in [Figure 6](#). The electrode board shown in this user guide is an example only. When connecting an electrode board, refer to [Figure 51](#) and the EVAL-ADPD6000Z schematic (see [Figure 55](#) and [Figure 56](#)), and connect the EVAL-ADPD6000Z with the electrodes according to Step 3 in the [PCB Connection](#) section.

After installing the EVAL-ADPD6000Z, place the wrist strap on the wrist as shown in [Figure 51](#), and generate the waveform (see [Figure 53](#) for reference).

There are the stickers labeled R (right) on one side and L (left) on the other side of the electrode board. While pressing the electrode board against the left arm, keep one finger on Electrode 1 and one finger on Electrode 2 (see [Figure 52](#)). While pressing the electrode board against the right arm, keep one finger on Electrode 3 and one finger on Electrode 4. In figure, the right hand fingers are pressing

HUMAN MEASUREMENT

against the R side of the electrode board, and the left wrist is against the L side of the electrode board.

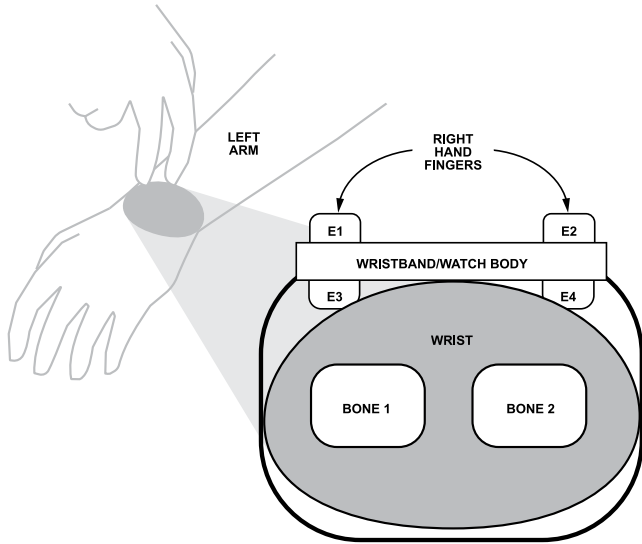

Figure 51. Wrist Strap Placement Diagram

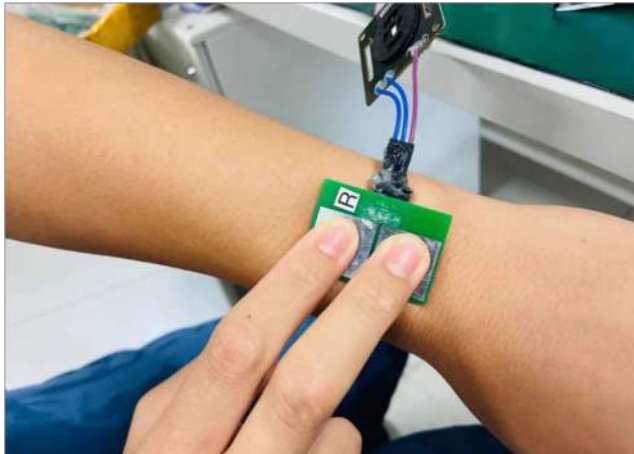

Figure 52. Electrode Board Placement



Figure 53. ECG Measurement Waveform

BIA MEASUREMENT

For BIA measurement, place the electrode board against the wrist in the same way as shown for ECG measurement (see Figure 52). Run VSM Client to display the BIA measurement results (see Figure 54 for an example). BIOZ amplitude is the body impedance of the user.



Figure 54. BIA Measurement Results

EVALUATION BOARD SCHEMATICS AND ARTWORK

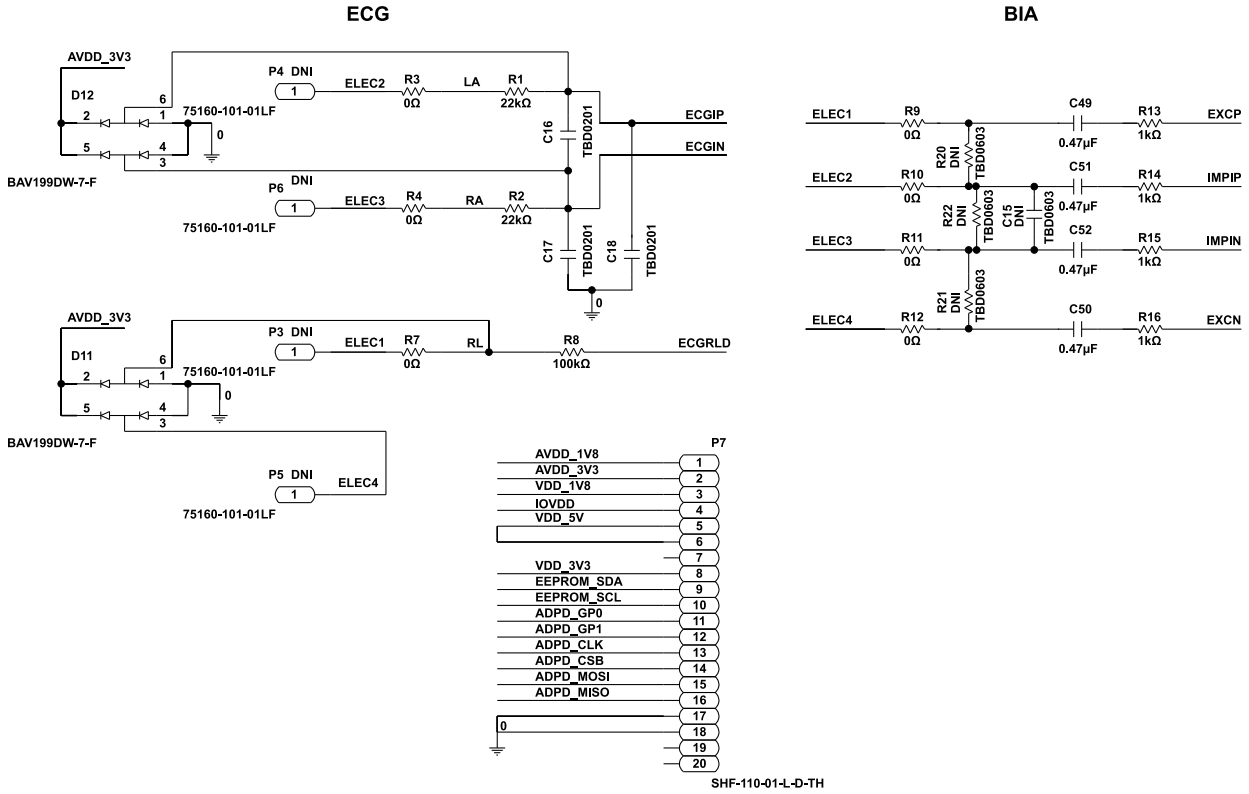

Figure 55. EVAL-ADPD6000Z Schematic, Page 1

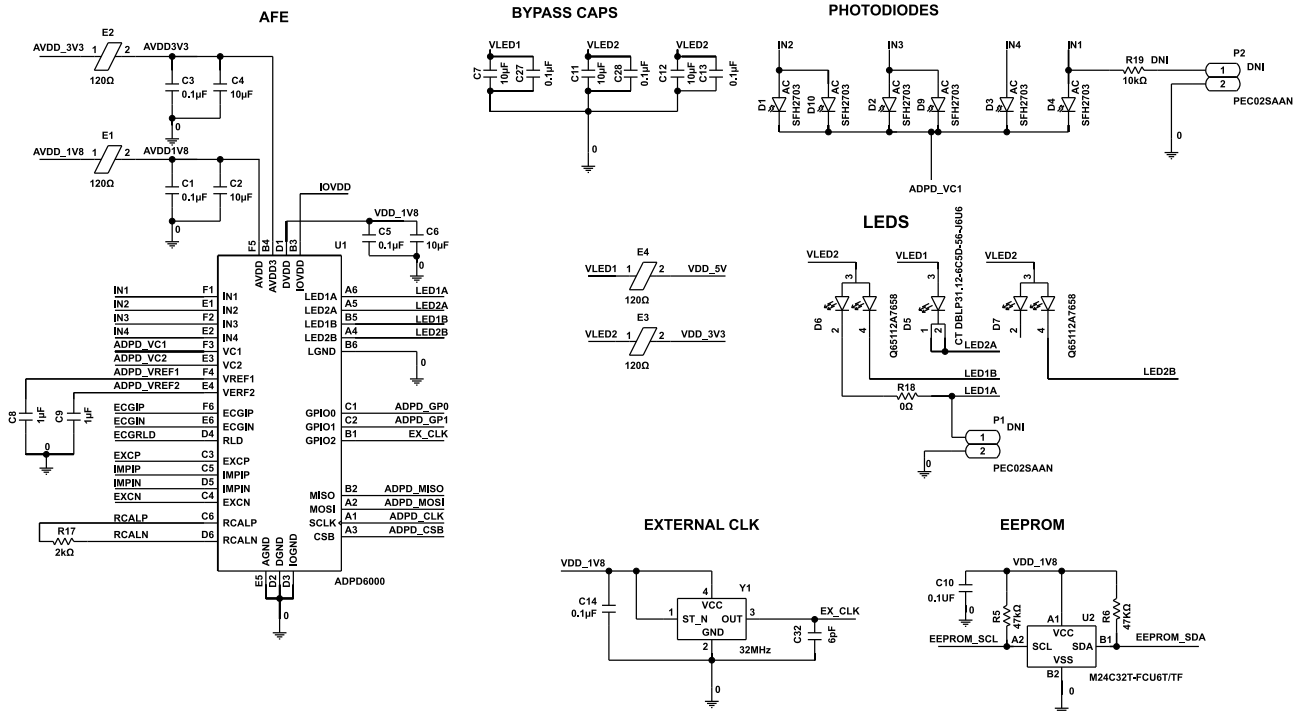

Figure 56. EVAL-ADPD6000Z Schematic, Page 2

EVALUATION BOARD SCHEMATICS AND ARTWORK

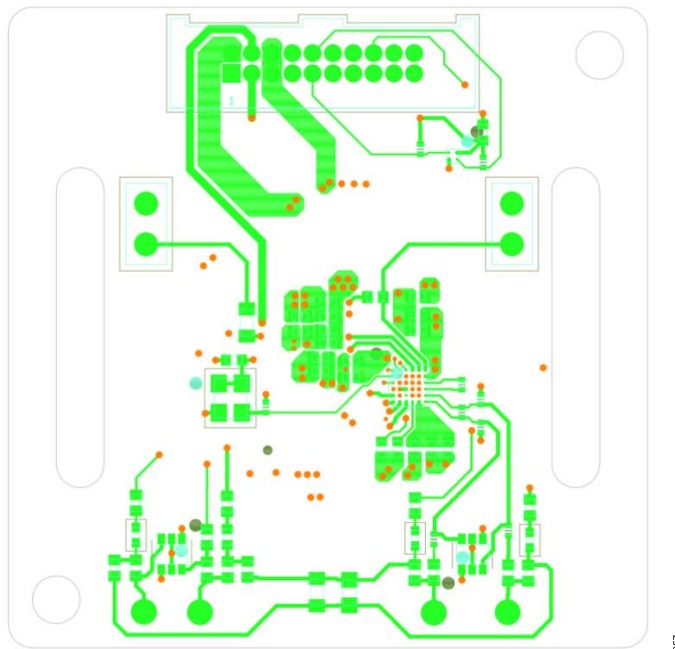

Figure 57. EVAL-ADPD6000Z PCB Layout: Top

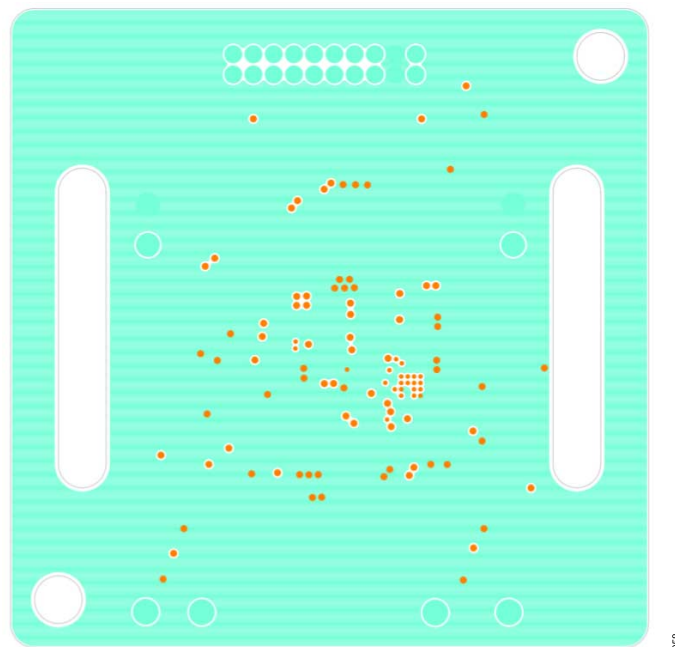
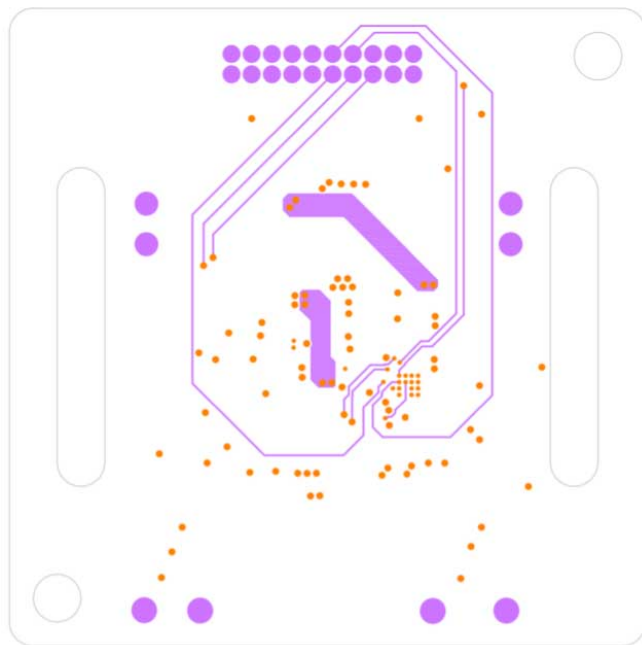

Figure 58. EVAL-ADPD6000Z PCB Layout: GND 1

EVALUATION BOARD SCHEMATICS AND ARTWORK



059

Figure 59. EVAL-ADPD6000Z PCB Layout: Inner Signal

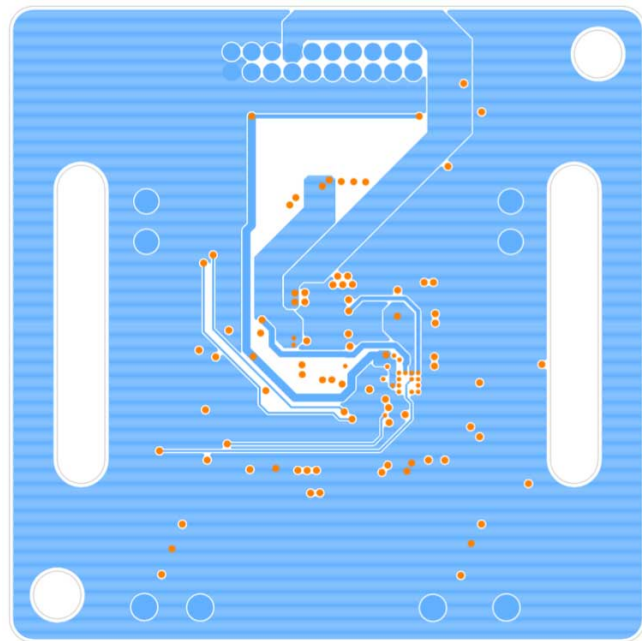

060

Figure 60. EVAL-ADPD6000Z PCB Layout: Power

EVALUATION BOARD SCHEMATICS AND ARTWORK

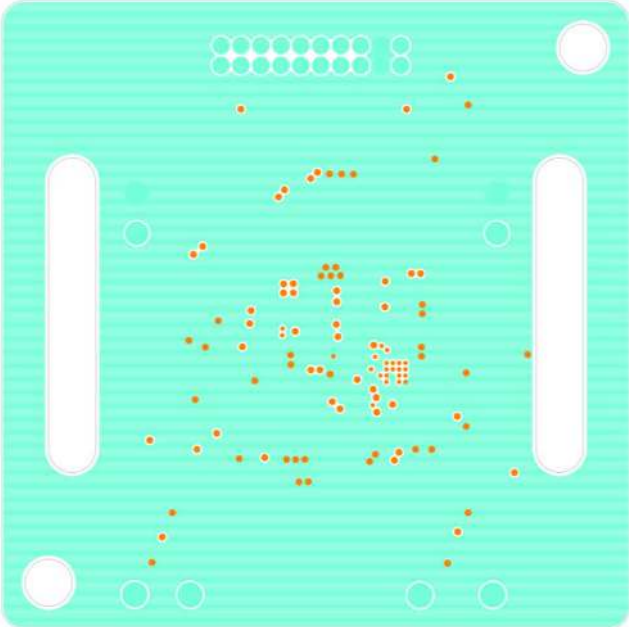

Figure 61. EVAL-ADPD6000Z PCB Layout: GND 2

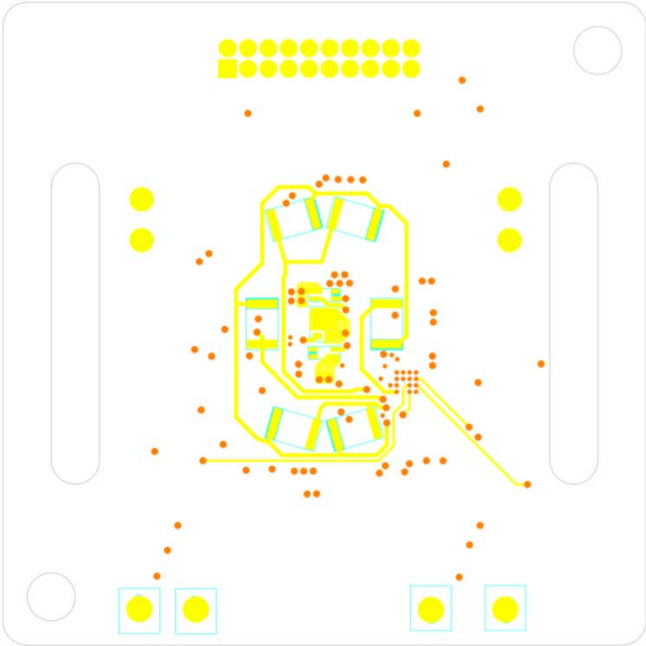

Figure 62. EVAL-ADPD6000Z PCB Layout: Bottom

EVALUATION BOARD SCHEMATICS AND ARTWORK

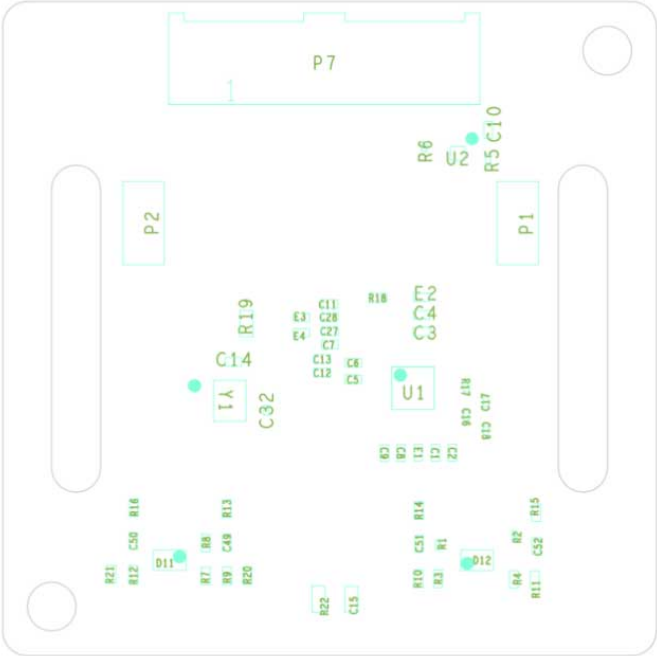

Figure 63. EVAL-ADPD6000Z PCB Layout: Assembly Top

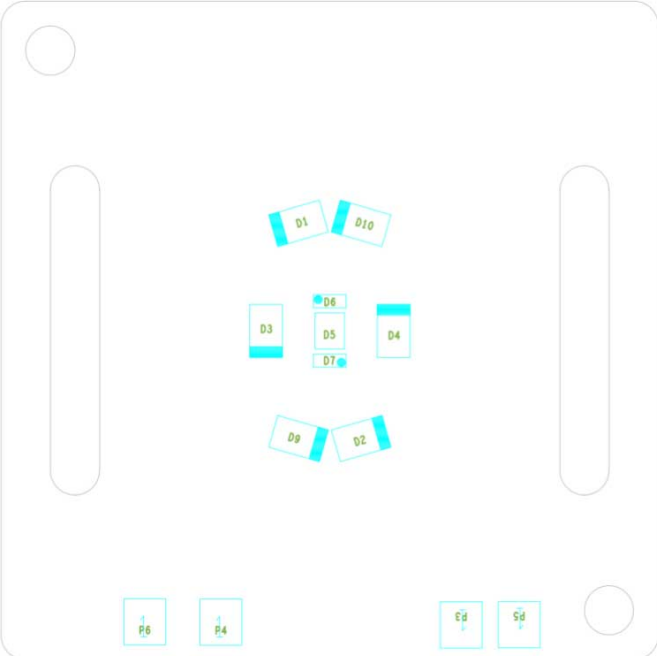

Figure 64. EVAL-ADPD6000Z PCB Layout: Assembly Bottom

NOTES

**ESD Caution**

ESD (electrostatic discharge) sensitive device. Charged devices and circuit boards can discharge without detection. Although this product features patented or proprietary protection circuitry, damage may occur on devices subjected to high energy ESD. Therefore, proper ESD precautions should be taken to avoid performance degradation or loss of functionality.

Legal Terms and Conditions

By using the evaluation board discussed herein (together with any tools, components documentation or support materials, the "Evaluation Board"), you are agreeing to be bound by the terms and conditions set forth below ("Agreement") unless you have purchased the Evaluation Board, in which case the Analog Devices Standard Terms and Conditions of Sale shall govern. Do not use the Evaluation Board until you have read and agreed to the Agreement. Your use of the Evaluation Board shall signify your acceptance of the Agreement. This Agreement is made by and between you ("Customer") and Analog Devices, Inc. ("ADI"), with its principal place of business at Subject to the terms and conditions of the Agreement, ADI hereby grants to Customer a free, limited, personal, temporary, non-exclusive, non-sublicensable, non-transferable license to use the Evaluation Board FOR EVALUATION PURPOSES ONLY. Customer understands and agrees that the Evaluation Board is provided for the sole and exclusive purpose referenced above, and agrees not to use the Evaluation Board for any other purpose. Furthermore, the license granted is expressly made subject to the following additional limitations: Customer shall not (i) rent, lease, display, sell, transfer, assign, sublicense, or distribute the Evaluation Board; and (ii) permit any Third Party to access the Evaluation Board. As used herein, the term "Third Party" includes any entity other than ADI, Customer, their employees, affiliates and in-house consultants. The Evaluation Board is NOT sold to Customer; all rights not expressly granted herein, including ownership of the Evaluation Board, are reserved by ADI. CONFIDENTIALITY. This Agreement and the Evaluation Board shall all be considered the confidential and proprietary information of ADI. Customer may not disclose or transfer any portion of the Evaluation Board to any other party for any reason. Upon discontinuation of use of the Evaluation Board or termination of this Agreement, Customer agrees to promptly return the Evaluation Board to ADI. ADDITIONAL RESTRICTIONS. Customer may not disassemble, decompile or reverse engineer chips on the Evaluation Board. Customer shall inform ADI of any occurred damages or any modifications or alterations it makes to the Evaluation Board, including but not limited to soldering or any other activity that affects the material content of the Evaluation Board. Modifications to the Evaluation Board must comply with applicable law, including but not limited to the RoHS Directive. TERMINATION. ADI may terminate this Agreement at any time upon giving written notice to Customer. Customer agrees to return to ADI the Evaluation Board at that time. LIMITATION OF LIABILITY. THE EVALUATION BOARD PROVIDED HEREUNDER IS PROVIDED "AS IS" AND ADI MAKES NO WARRANTIES OR REPRESENTATIONS OF ANY KIND WITH RESPECT TO IT. ADI SPECIFICALLY DISCLAIMS ANY REPRESENTATIONS, ENDORSEMENTS, GUARANTEES, OR WARRANTIES, EXPRESS OR IMPLIED, RELATED TO THE EVALUATION BOARD INCLUDING, BUT NOT LIMITED TO, THE IMPLIED WARRANTY OF MERCHANTABILITY, TITLE, FITNESS FOR A PARTICULAR PURPOSE OR NON-INFRINGEMENT OF INTELLECTUAL PROPERTY RIGHTS. IN NO EVENT WILL ADI AND ITS LICENSORS BE LIABLE FOR ANY INCIDENTAL, SPECIAL, INDIRECT, OR CONSEQUENTIAL DAMAGES RESULTING FROM CUSTOMER'S POSSESSION OR USE OF THE EVALUATION BOARD, INCLUDING BUT NOT LIMITED TO LOST PROFITS, DELAY COSTS, LABOR COSTS OR LOSS OF GOODWILL. ADI'S TOTAL LIABILITY FROM ANY AND ALL CAUSES SHALL BE LIMITED TO THE AMOUNT OF ONE HUNDRED US DOLLARS (\$100.00). EXPORT. Customer agrees that it will not directly or indirectly export the Evaluation Board to another country, and that it will comply with all applicable United States federal laws and regulations relating to exports. GOVERNING LAW. This Agreement shall be governed by and construed in accordance with the substantive laws of the Commonwealth of Massachusetts (excluding conflict of law rules). Any legal action regarding this Agreement will be heard in the state or federal courts having jurisdiction in Suffolk County, Massachusetts, and Customer hereby submits to the personal jurisdiction and venue of such courts. The United Nations Convention on Contracts for the International Sale of Goods shall not apply to this Agreement and is expressly disclaimed.

