

PART NUMBER	REV	FIRST USED
680440-1	A	854400-1
680440-2	A	565435-5
680440-3	A	354500-1

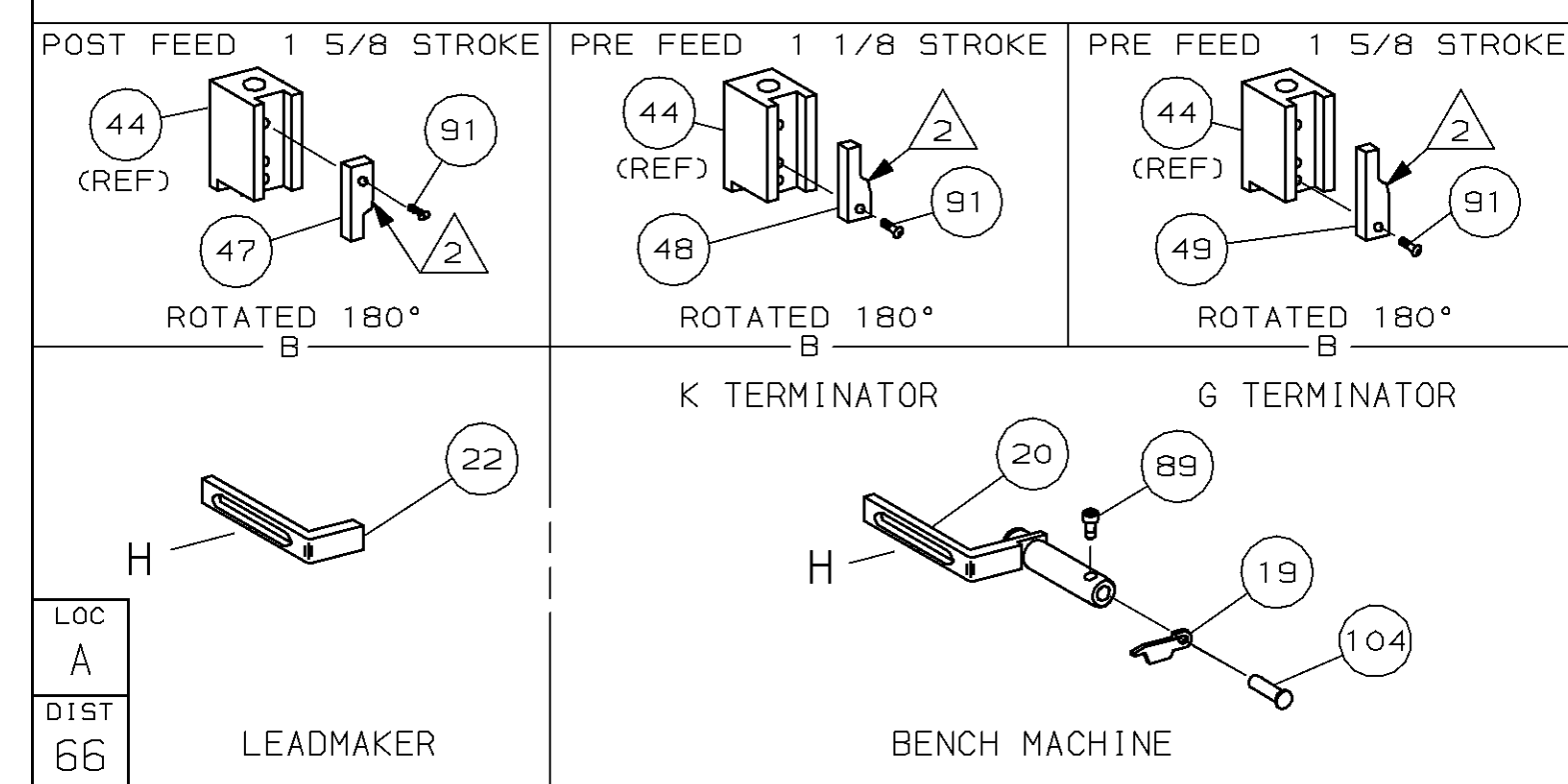
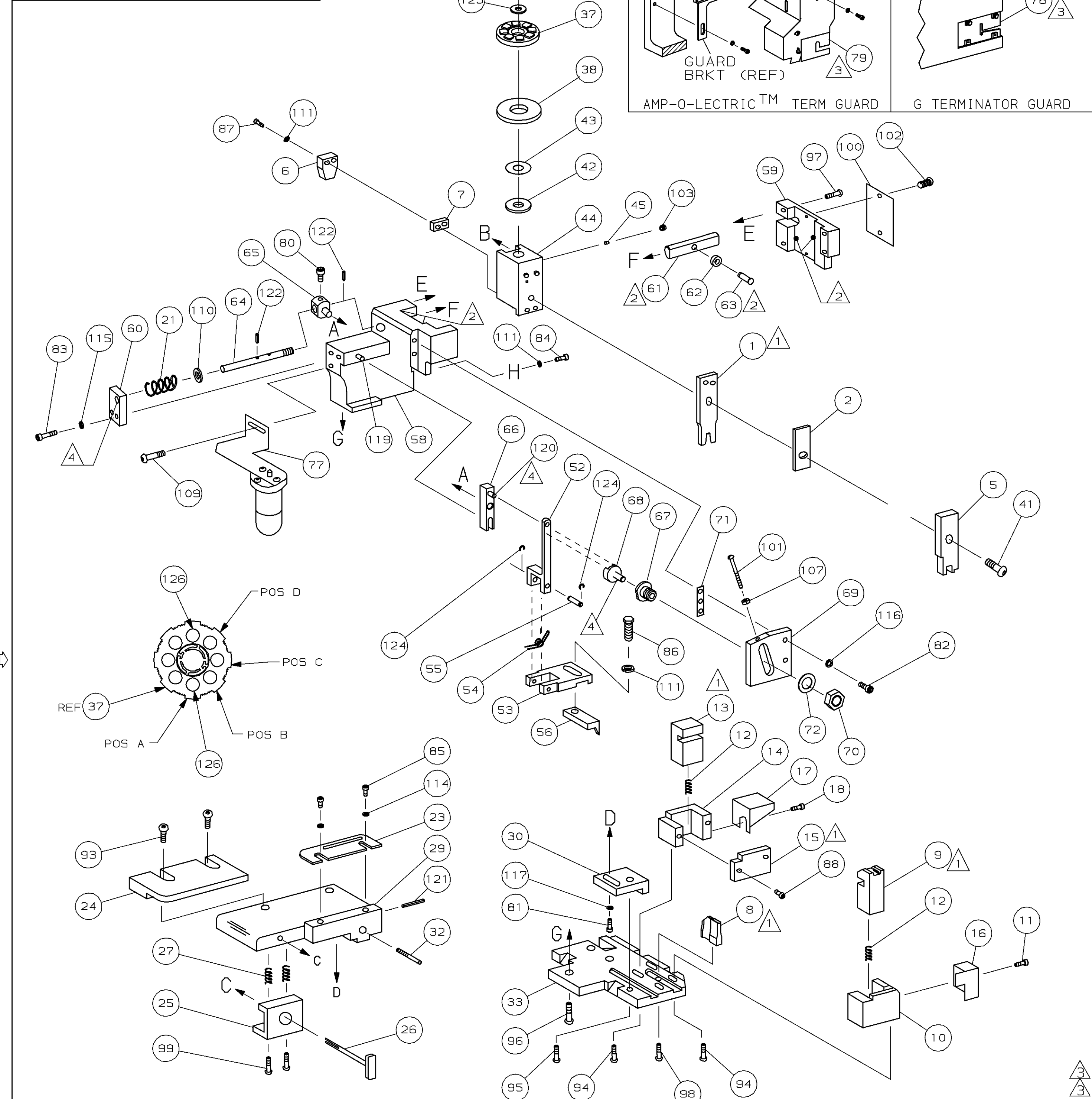

- 1 RECOMMENDED SPARE PARTS.
- 2 GREASE LIGHTLY.
- 3 GUARD MUST BE IN PLACE WHEN OPERATING APPLICATOR IN A BENCH MACHINE.
- 4 LUBRICATE DAILY USING NO. 20 MACHINE OIL.
- 5. ITEMS WITH QTY OF REF SPECIFIED (EXCEPT ITEMS 78 AND 79) ARE USED ON ITEM 46.
- 6 LUBRICATION REQUIRED WITH NICKEL PLATED TERMINALS.
- 7 FOR ALUMINUM WIRE

CRIMPING DATA			
PAD LTR	CRIMP HEIGHT		
A	.112 ±.002 [2.84 ±0.05mm]		
B	NOT USED		
C	NOT USED		
D	NOT USED		
CRIMP	SIZE	TYPE	RANGE
WIRE	.155 [3.94mm]	F	9 ALUMINUM
INSUL	-	-	-

WIRE STRIP LENGTH	TERM APPL SPEC	FEED	APPL INSTRUCTION	SET UP GAGE	LAYOUT
.235-.266	114-2017	.626	408-8040	458637-1	142

129							
128							
127							
2	2	2	-	C	1-354778-9	PIN, WIRE DISC (.2590)A	126
1	1	1	-	A	986950-1	WASHER, FLAT PRECISION	125
REF	REF	REF	-	A	21045-3	RING, RET "C" (Ø.187)FD FING PIN	124
							123
REF	REF	REF	-	A	5-21028-1	PIN, SLT SPR (Ø.125x.50)ADJ ROD	122
1	1	1	-	A	4-21028-0	PIN, SLT SPR (Ø.093x.75)ST GDE PL	121
REF	REF	REF	-	A	1-21030-1	PIN, DOWEL (Ø.187x.50)LEVER	120
REF	REF	REF	-	A	1-21030-6	PIN, DOWEL (Ø.187x1.25)HOUSING	119
							118
1	1	1	-	A	21024-5	WASHER, LOCK (#10)ADJ BLOCK	117
REF	REF	REF	-	A	21024-5	WASHER, LOCK (#10)ADJ PLATE	116
REF	REF	REF	-	A	21024-5	WASHER, LOCK (#10)FEED GDE ROD	115
2	2	2	-	A	21024-2	WASHER, LOCK (#4)FRONT STP GUIDE	114
							113
							112
4	4	4	-	A	21024-4	WASHER, LOCK (#8)STRIPPER	111
REF	REF	REF	-	A	21899-4	WASHER, FLAT (Ø5/16)SCREW ADJ	110
-	1	-	-	A	2-21002-6	SCR, BHC (10-32x.38)LUBE ASSY	109
							108
REF	REF	REF	-	A	21018-5	NUT, HEX (6-32)FEED ADJ	107
							106
							105
1	1	-	-	A	992031-1	PIN, CLEVIS	104
1	1	1	-	A	21009-2	SCR, SKT SET (1/4-20x.25 LW)RAM	103
2	2	2	-	A	21017-2	SCR, DRIVE (#2x.19)ID PLATE	102
REF	REF	REF	-	A	6-23715-5	SCR, PAN HD (6-32x1.50)FEED ADJ	101
1	1	1	-	B	461264-1	PLATE, IDENTIFICATION	100
2	2	2	-	A	3-21002-0	SCR, BHC (10-32x.88)DRAG	99
1	1	1	-	A	22733-8	SCR, BHC (8-32x.38 LW)ANVIL	98
REF	REF	REF	-	A	2-21002-9	SCR, BHC (10-32x.75)CAP	97
REF	REF	REF	-	A	2-22733-8	SCR, BHC (1/4-20x.62)HOUSING	96
REF	REF	REF	-	A	2-21002-7	SCR, BHC (10-32x.50)SG ADJ BLOCK	95
4	4	4	-	A	2-21002-2	SCR, BHC (8-32x.50)SHEAR	94
2	2	2	-	A	2-21000-2	SCR, SHC (6-32x.75)R STRIP GUIDE	93
							92
1	1	1	-	A	1-21002-7	SCR, BHC (6-32x.38)CAM	91
							90
1	1	-	-	A	7-21000-9	SCR, SHC (4-40x.19)STRIPPER	89
2	2	2	-	A	1-21000-8	SCR, SHC (6-32x.25)R SHEAR PLATE	88
2	2	2	-	A	3-21000-0	SCR, SHC (8-32x.88)DEP-HOLD	87
1	1	1	-	A	2-22603-0	SCR, HEX HD (8-32x.31)FEED FINGER	86
2	2	2	-	A	1-21000-3	SCR, SHC (4-40x.25)F ST GUIDE	85
1	1	1	-	A	2-21000-7	SCR, SHC (8-32x.50)STRIPPER	84
REF	REF	REF	-	A	3-21000-7	SCR, SHC (10-32x.75)FEED ROD GD	83
REF	REF	REF	-	A	3-21000-6	SCR, SHC (10-32x.62)FD ADJ BLK	82
1	1	1	-	A	3-21000-4	SCR, SHC (10-32x.38)SG ADJ BL	81
REF	REF	REF	-	A	3-21000-4	SCR, SHC (10-32x.38)PIVOT BLK	80
-	REF	-	-	B	455749-1	GUARD, WINDOW	79
REF	-	-	-	B	679532-1	INSERT, GUARD	78
-	1	-	-	C	1-465184-0	LUBRICATOR ASSY	77
							76
							75
							74
							73
							72
REF	REF	REF	-	A	458109-1	WASHER, SPECIAL	71
REF	REF	REF	-	A	690517-1	SPACER	70

QTY REQD PER ASSY	U/M	DWG SIZE	PART NO	DESCRIPTION	ITEM NO

P/F LTR		REVISED	REVISION RECORD	CE APP	3-97 DATE

LEADMAKER		MECH POST FEED	
-1	BENCH MODEL K	MECH PRE FEED	
-2	BENCH MODEL G	MECH PRE FEED	
-3	BENCH MODEL G	MECH PRE FEED	

REF	REF	REF	-	B	22594-8	NUT, HEX (1/2-20)	70
REF	REF	REF	-	B	240628-1	PLATE, ADJUSTMENT	69
REF	REF	REF	-	B	240626-1	SHAFT, PIVOT	68
REF	REF	REF	-	B	240633-1	BUSHING	67
REF	REF	REF	-	A	455680-1	LEVER, INTERMEDIATE	66
REF	REF	REF	-	B	240629-1	BLOCK, PIVOT	65
REF	REF	REF	-	A	240632-2	SCREW, ADJ FEED ROD	64
REF	REF	REF	-	B	240659-3	PIN, CAM ROLLER	63
REF	REF	REF	-	B	240658-1	ROLLER, CAM	62
REF	REF	REF	-	B	454398-2	ROD, FEED	61
REF	REF	REF	-	A	454178-1	GUIDE, FEED ROD	60
REF	REF	REF	-	C	454220-1	CAP, RAM	59
REF	REF	REF	-	D	454485-1	HOUSING	58
							57
							56
1	1	1	-	B	690542-3	PAWL, FEED	55
REF	REF	REF	-	B	240624-1	PIN, FEED FINGER	54
REF	REF	REF	-	B	691499-1	SPRING, FEED FINGER	53
REF	REF	REF	-	B	690541-1	HOLDER, FEED FINGER	52
REF	REF	REF	-	A	455679-1	LEVER, TERMINAL FEED ARM	51
							50
							49
1	-	-	-	B	690602-6	CAM, PRE-FEED 1 5/8 ST	48
-	1	-	-	B	690602-5	CAM, PRE-FEED 1 1/8 ST	47
-	-	1	-	B	690501-4	CAM, POST-FEED 1 5/8 ST	46
1	1	1	-	B	459456-1	APPLICATOR, BASIC (SUBASSY)	45
1	1	1	-	A	690191-1	PLUG, NYLON	44
1	1	1	-	C	455673-1	RAM	43
1	1	1	-	A	690125-1	WASHER, LAMINATED	42
1	1	1	-	A	1-690124-0	WASHER, RAM	41
1	1	1	-	A	7-21002-9	BOLT, CRIMPER (5/16x1.00)	40
							39
							38
1	1	1	-	A	690223-2	SPACER, INSULATION DISC	37
1	1	1	-	D	354777-1	WIRE DISC, PLASTIC	36
1	1	1	-	A	22480-5	WASHER, SPRING	35
1	1	1	-	B	690212-1	POST, RAM	34
							33
REF	REF	REF	-	D	455675-1	PLATE, BASE	32
1	1	1	-	A	690432-3	SCREW, ADJUSTMENT	31
							30
REF	REF	REF	-	B	455689-1	BLOCK, STRIP GUIDE ADJ	29
1	1	1	-	C	455671-1	PLATE, STRIP GUIDE	28
							27
2	2	2	-	A	1-22284-0	SPRING, DRAG	26
1	1	1	-	B	690546-1	LEVER, DRAG RELEASE	25
1	1	1	-	B	240792-5	DRAG, TERMINAL	24
1	1	1	-	D	2-690504-8	GUIDE, STRIP (REAR)	23
1	1	1	-	A	693855-1	GUIDE, STRIP (FRONT)	22
-	-	1	-	B	690472-1	STRIPPER	21
REF	REF	REF	-	A	4-22284-9	SPRING, FEED RETURN	20
1	1	-	-	A	679218-1	STRIPPER WIRE STOP ASSY	19
1	1	-	-	B	458949-1	STRIPPER	18
1	1	1	-	B	690461-1	STOP, SHEAR, REAR	17
1	1	1	-	A	691668-1	GUARD, CHIP (REAR)	16
1	1	1	-	B	691667-1	GUARD, CHIP (FRONT)	15
1	1	1	-	B	690631-2	PLATE, SHEAR (REAR)	14
1	1	1	-	B	690462-1	HOLDER, SHEAR (REAR)	13
1	1	1	-	C	690463-1	SHEAR, FLOAT (REAR)	12
2	2	2	-	A	5-22280-0	SPRING, SHEAR	11
1	1	1	-	B	690461-7	STOP, SHEAR, FRONT	10
1	1	1	-	C	1-690459-0	HOLDER, SHEAR (FRONT)	9
1	1	1	-	C	454276-5	SHEAR, FLOAT (FRONT)	8
1	1	1	-	C	904132-7	ANVIL	7
1	1	1	-	C	2-240641-6	SPACER, DEPRESSOR (REAR)	6
1	1	1	-	A	690468-1	DEPRESSOR, SHEAR (REAR)	5
1	1	1	-	C	1-455889-6	DEPRESSOR, SHEAR (FRONT)	4
							3
							2
1	1	1	-	C	455888-6	SPACER, CRIMPER	1
1	1	1	-	C	456415-2	CRIMPER, WIRE	

QTY REQD PER ASSY		PARTS LIST	

DIMENSIONS IN INCHES. DO NOT SCALE PRINT. TOLERANCES UNLESS OTHERWISE SPECIFIED.		MATERIAL		FINISH	
DR	11MAR97	APP	11MAR97	HT TR	-
C.ERISMAN			J.DODDS		
2	PLC DEC ±				
3	PLC DEC ±				
4	PLC DEC ±				
ANGLES ±					
SURF TEXTURE: ✓					
REMOVE BURRS, BREAK SHARP EDGES R.015 MAX					

NAME	SCALE	DWG NO	680440	MACHINE REF	MINI APPL
SIDE FEED HDM APPLICATOR					

THIS DRAWING IS A CONTROLLED DOCUMENT FOR AMP INCORPORATED. IT IS SUBJECT TO CHANGE AND THE CONTROLLING ENGINEERING ORGANIZATION SHOULD BE CONTACTED FOR THE LATEST REVISION.

THIS INFORMATION IS CONFIDENTIAL AND IS DISCLOSED TO YOU ON CONDITION THAT NO FURTHER DISCLOSURE IS MADE BY YOU TO OTHER THAN AMP PERSONNEL WITHOUT WRITTEN AUTHORIZATION FROM AMP INCORPORATED, HARRISBURG, PA.