

HV508

Functional Block Diagram

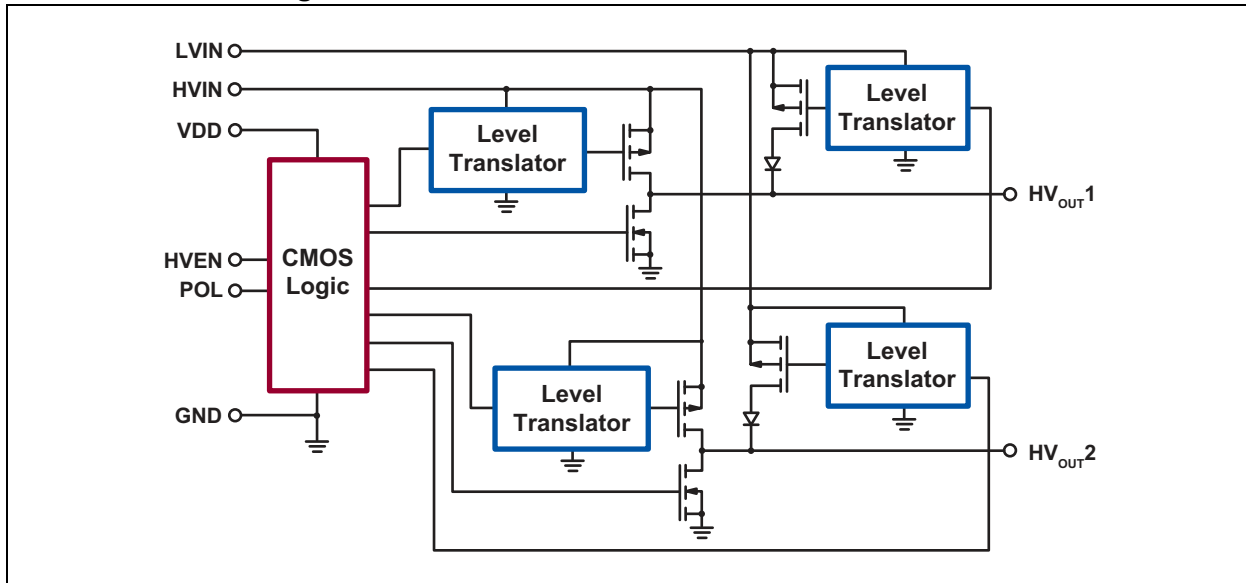

Typical Application Circuit

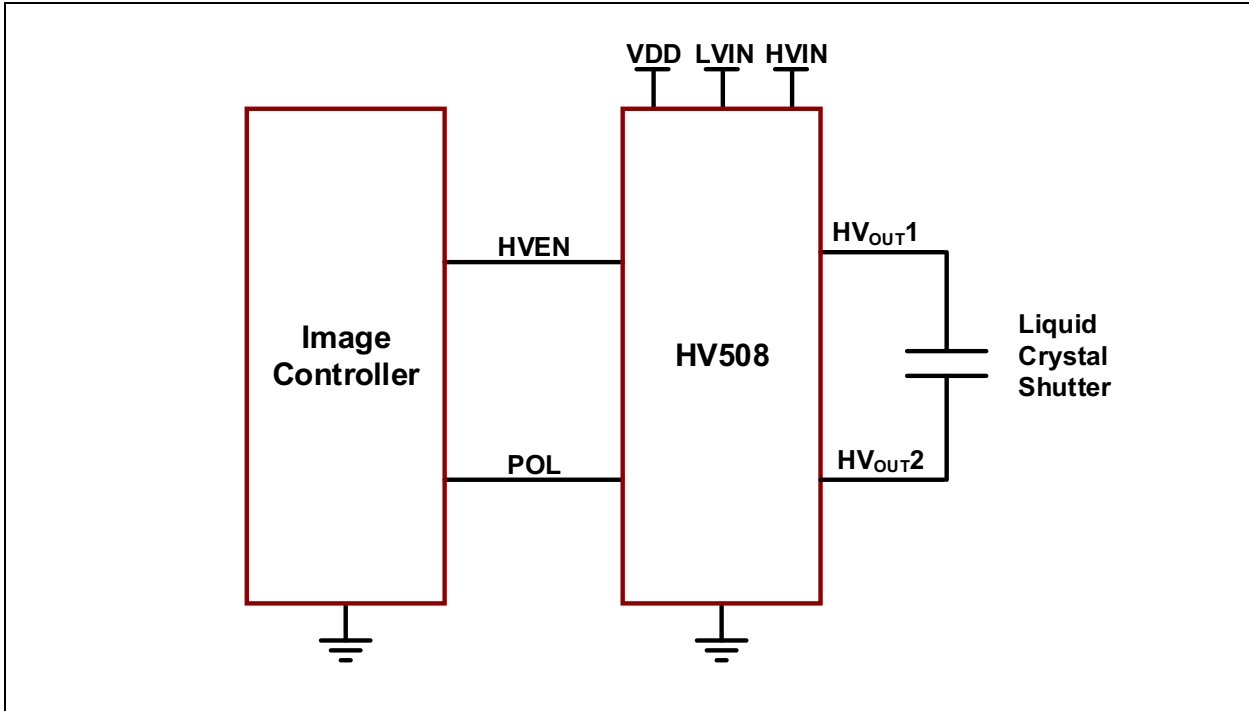

HV508

1.0 ELECTRICAL CHARACTERISTICS

Absolute Maximum Ratings†

High-voltage Input, V_{VIN}	+60V
Low-voltage Input, V_{LVIN}	+7.5V
Logic Supply voltage, V_{DD}	+12V
Operating Ambient Temperature, T_A	-5°C to +60°C
Storage Temperature, T_S	-65°C to +150°C
Power Dissipation (Note 1):	
8-lead SOIC	700 mW

† **Notice:** Stresses above those listed under “Absolute Maximum Ratings” may cause permanent damage to the device. This is a stress rating only, and functional operation of the device at those or any other conditions above those indicated in the operational sections of this specification is not intended. Exposure to maximum rating conditions for extended periods may affect device reliability.

Note 1: For operation above 25°C ambient, derate linearly at 6 mW/°C.

RECOMMENDED OPERATING CONDITIONS

Parameter	Sym.	Min.	Typ.	Max.	Unit	Conditions
Logic Supply Voltage	V_{DD}	5	—	10	V	
Low-output Supply Voltage	V_{LVIN}	3	—	6	V	
High-output Supply Voltage	V_{VIN}	5	—	45	V	
Logic Input Voltage Low	V_{IL}	0	—	0.3 V_{DD}	V	
Logic Input Voltage High	V_{IH}	0.7 V_{DD}	—	V_{DD}	V	
Ambient Temperature	T_A	-5	—	+60	°C	

DC ELECTRICAL CHARACTERISTICS

Electrical Specifications: Over operating supply voltages; $T_A = -5^\circ\text{C}$ to $+60^\circ\text{C}$ unless otherwise indicated.						
Parameter	Sym.	Min.	Typ.	Max.	Unit	Conditions
V_{VIN} Quiescent Current	I_{HVQ}	—	—	10	μA	
V_{LVIN} Quiescent Current	I_{LVQ}	—	—	10	μA	
V_{DD} Quiescent Current	I_{DDQ}	—	—	10	μA	
V_{VIN} Operating Current	I_{HV}	—	—	2.8	mA	POL = 100 Hz, $V_{VEN} = \text{high}$, $T_A = 25^\circ\text{C}$, Load = 1 M Ω in parallel with 0.1 μF between V_{OUT1} and V_{OUT2}
V_{LVIN} Operating Current	I_{LV}	—	—	380	μA	POL = 100 Hz, $V_{VEN} = \text{low}$, $T_A = 25^\circ\text{C}$, Load = 1 M Ω in parallel with 0.1 μF between V_{OUT1} and V_{OUT2}
Logic Input Current Low	I_{IL}	-5	—	—	μA	
Logic Input Current High	I_{IH}	—	—	5	μA	
Output Capacitive Load	C_{LOAD}	0	—	0.25	μF	C_{LOAD} in parallel with a 1 M Ω resistor (Note 1)

Note 1: The device can operate continuously in this range without damage. AC limits are not implemented.

AC ELECTRICAL CHARACTERISTICS

Electrical Specifications: $HV_{IN} = 45V$, $LV_{IN} = 6V$, $V_{DD} = 5V$, and $T_A = -5^{\circ}C$ to $+60^{\circ}C$.

Parameter	Sym.	Min.	Typ.	Max.	Unit	Conditions
POL Input Frequency	f_{POL}	0	—	100	Hz	
Turn-on Time when High-voltage is Enabled	$t_{HV(ON)}$	—	—	16	μs	Load = 1 M Ω in parallel with 0.1 μF between HV_{OUT1} and HV_{OUT2} , $HV_{EN} =$ high, outputs rise to HV_{IN} (See Fig.1 in Timing Waveforms.)
Turn-off Time when high-voltage is Enabled	$t_{HV(OFF)}$	—	—	16	μs	
Turn-on time when High-voltage is Disabled	$t_{LV(ON)}$	—	—	40	μs	Load = 1 M Ω in parallel with 0.1 μF between HV_{OUT1} and HV_{OUT2} , $HV_{EN} =$ low, outputs rise to HV_{IN} (See Fig.1 in Timing Waveforms.)
Turn-off time when High-voltage is Disabled	$t_{LV(OFF)}$	—	—	6	μs	
Turn-on time from HV_{EN} to HV_{OUT}	$t_{EN(ON)}$	—	—	25	μs	Load = 1 M Ω in parallel with 0.1 μF between HV_{OUT1} and HV_{OUT2} (See Fig.2 in Timing Waveforms.)

TEMPERATURE SPECIFICATIONS

Parameter	Sym.	Min.	Typ.	Max.	Unit	Conditions
TEMPERATURE RANGE						
Operating Ambient Temperature	T_A	-5	—	+60	$^{\circ}C$	
Storage Temperature	T_S	-65	—	+150	$^{\circ}C$	
PACKAGE THERMAL RESISTANCE						
8-lead SOIC	θ_{JA}	—	101	—	$^{\circ}C/W$	

Timing Waveforms

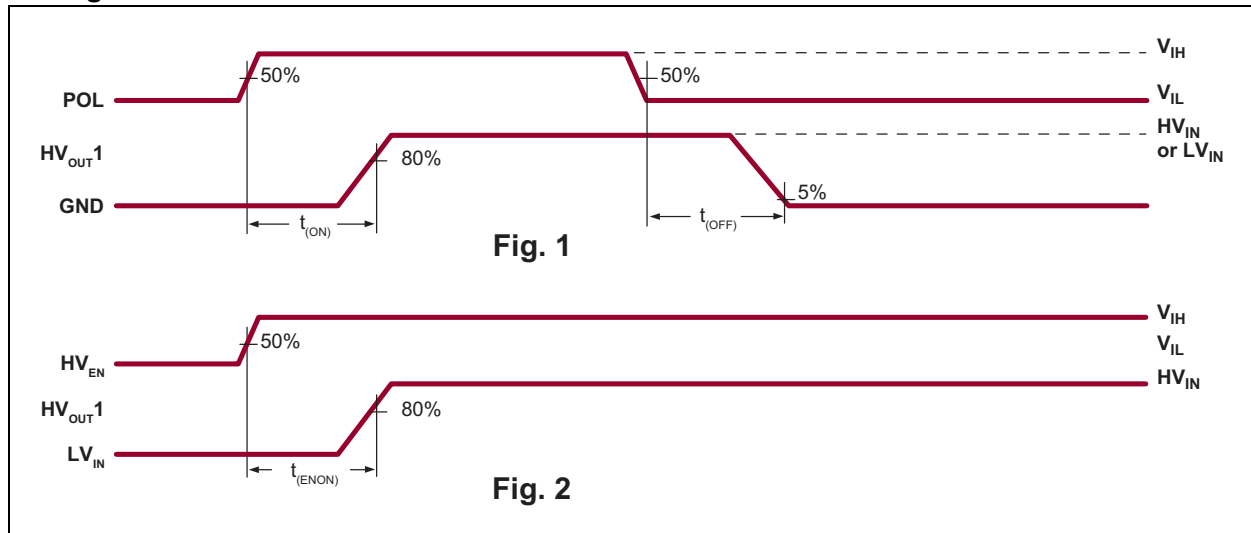

HV508

2.0 PIN DESCRIPTION

The details on the pins of HV508 are listed on [Table 2-1](#). Refer to [Package Type](#) for the location of pins.

TABLE 2-1: PIN FUNCTION TABLE

Pin Number	Pin Name	Description
1	LVIN	Low Voltage Supply
2	POL	Polarity
3	HVEN	High Voltage Enable
4	GND	Ground
5	HVOUT2	High Voltage Output Channel 2
6	VDD	Logic Voltage Supply
7	HVIN	High Voltage Supply
8	HVOUT1	High Voltage Output Channel 1

3.0 FUNCTIONAL DESCRIPTION

Follow the steps in [Table 3-1](#) to power up and power down the HV508.

TABLE 3-1: POWER-UP AND POWER-DOWN SEQUENCE

Power-up		Power-down	
Step	Description	Step	Description
1	Connect ground.	1	Remove LV _{IN} .
2	Apply V _{DD} .	2	Remove HV _{IN} .
3	Connect logic Inputs.	2	Remove all logic inputs.
4	Connect HV _{IN} .	3	Remove V _{DD} .
5	Connect LV _{IN} .	4	Disconnect ground.

TABLE 3-2: TRUTH FUNCTION TABLE

HV _{EN}	POL	HV _{OUT1}	HV _{OUT2}
H	H	HV _{IN}	GND
H	L	GND	HV _{IN}
L	H	LV _{IN}	GND
L	L	GND	LV _{IN}

HV508

4.0 PACKAGE MARKING INFORMATION

4.1 Packaging Information

8-lead SOIC

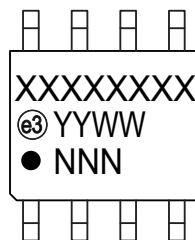

Example

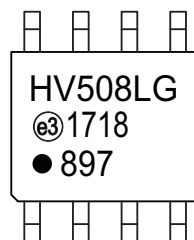

Legend:	XX...X	Product Code or Customer-specific information
	Y	Year code (last digit of calendar year)
	YY	Year code (last 2 digits of calendar year)
	WW	Week code (week of January 1 is week '01')
	NNN	Alphanumeric traceability code
	ⓔ3	Pb-free JEDEC [®] designator for Matte Tin (Sn)
	*	This package is Pb-free. The Pb-free JEDEC designator (ⓔ3) can be found on the outer packaging for this package.

Note: In the event the full Microchip part number cannot be marked on one line, it will be carried over to the next line, thus limiting the number of available characters for product code or customer-specific information. Package may or not include the corporate logo.

8-Lead SOIC (Narrow Body) Package Outline (LG/TG) 4.90x3.90mm body, 1.75mm height (max), 1.27mm pitch

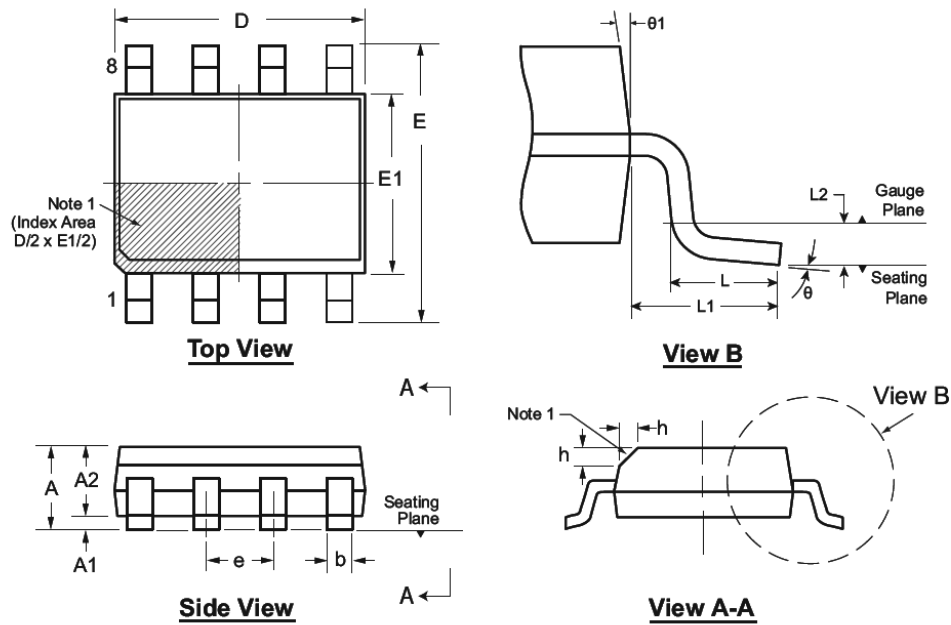

Note: For the most current package drawings, see the Microchip Packaging Specification at www.microchip.com/packaging.

Note:

1. This chamfer feature is optional. A Pin 1 identifier must be located in the index area indicated. The Pin 1 identifier can be: a molded mark/identifier, an embedded metal marker, or a printed indicator.

Symbol	A	A1	A2	b	D	E	E1	e	h	L	L1	L2	θ	$\theta 1$	
Dimension (mm)	MIN	1.35*	0.10	1.25	0.31	4.80*	5.80*	3.80*	1.27 BSC	0.25	0.40	1.04 REF	0.25 BSC	0°	5°
	NOM	-	-	-	-	4.90	6.00	3.90		-	-			-	-
	MAX	1.75	0.25	1.65*	0.51	5.00*	6.20*	4.00*		0.50	1.27			8°	15°

JEDEC Registration MS-012, Variation AA, Issue E, Sept. 2005.

* This dimension is not specified in the JEDEC drawing.

Drawings are not to scale.

HV508

NOTES:

APPENDIX A: REVISION HISTORY

Revision A (March 2017)

- Converted Supertex Doc# DSFP-HV508 to Microchip DS20005728A
- Removed “HVCMOS[®] Technology” throughout the data sheet
- Changed part marking format
- Changed the quantity of the 8-lead SOIC LG package from 2500/Reel to 3300/Reel
- Made minor text changes throughout the document

HV508

PRODUCT IDENTIFICATION SYSTEM

To order or obtain information, e.g., on pricing or delivery, contact your local Microchip representative or sales office.

<u>PART NO.</u>	<u>XX</u>	-	<u>X</u>	-	<u>X</u>
Device	Package Options		Environmental		Media Type
Device:	HV508	=	High-Voltage Liquid Crystal Shutter Driver		
Package:	LG	=	8-lead SOIC		
Environmental:	G	=	Lead (Pb)-free/RoHS-compliant Package		
Media Type:	(blank)	=	3300/Reel for an LG Package		

Example:

a) HV508LG-G: High-Voltage Liquid Crystal Shutter Driver, 8-lead SOIC, 3300/Reel

Note the following details of the code protection feature on Microchip devices:

- Microchip products meet the specification contained in their particular Microchip Data Sheet.
- Microchip believes that its family of products is one of the most secure families of its kind on the market today, when used in the intended manner and under normal conditions.
- There are dishonest and possibly illegal methods used to breach the code protection feature. All of these methods, to our knowledge, require using the Microchip products in a manner outside the operating specifications contained in Microchip's Data Sheets. Most likely, the person doing so is engaged in theft of intellectual property.
- Microchip is willing to work with the customer who is concerned about the integrity of their code.
- Neither Microchip nor any other semiconductor manufacturer can guarantee the security of their code. Code protection does not mean that we are guaranteeing the product as “unbreakable.”

Code protection is constantly evolving. We at Microchip are committed to continuously improving the code protection features of our products. Attempts to break Microchip's code protection feature may be a violation of the Digital Millennium Copyright Act. If such acts allow unauthorized access to your software or other copyrighted work, you may have a right to sue for relief under that Act.

Information contained in this publication regarding device applications and the like is provided only for your convenience and may be superseded by updates. It is your responsibility to ensure that your application meets with your specifications. MICROCHIP MAKES NO REPRESENTATIONS OR WARRANTIES OF ANY KIND WHETHER EXPRESS OR IMPLIED, WRITTEN OR ORAL, STATUTORY OR OTHERWISE, RELATED TO THE INFORMATION, INCLUDING BUT NOT LIMITED TO ITS CONDITION, QUALITY, PERFORMANCE, MERCHANTABILITY OR FITNESS FOR PURPOSE. Microchip disclaims all liability arising from this information and its use. Use of Microchip devices in life support and/or safety applications is entirely at the buyer's risk, and the buyer agrees to defend, indemnify and hold harmless Microchip from any and all damages, claims, suits, or expenses resulting from such use. No licenses are conveyed, implicitly or otherwise, under any Microchip intellectual property rights unless otherwise stated.

Microchip received ISO/TS-16949:2009 certification for its worldwide headquarters, design and wafer fabrication facilities in Chandler and Tempe, Arizona; Gresham, Oregon and design centers in California and India. The Company's quality system processes and procedures are for its PIC® MCUs and dsPIC® DSCs, KEELOQ® code hopping devices, Serial EEPROMs, microperipherals, nonvolatile memory and analog products. In addition, Microchip's quality system for the design and manufacture of development systems is ISO 9001:2000 certified.

**QUALITY MANAGEMENT SYSTEM
CERTIFIED BY DNV
= ISO/TS 16949 =**

Trademarks

The Microchip name and logo, the Microchip logo, AnyRate, AVR, AVR logo, AVR Freaks, BeaconThings, BitCloud, CryptoMemory, CryptoRF, dsPIC, FlashFlex, flexPWR, Heldo, JukeBlox, KEELOQ, KEELOQ logo, Klear, LANCheck, LINK MD, maXStylus, maXTouch, MediaLB, megaAVR, MOST, MOST logo, MPLAB, OptoLyzer, PIC, picoPower, PICSTART, PIC32 logo, Prochip Designer, QTouch, RightTouch, SAM-BA, SpyNIC, SST, SST Logo, SuperFlash, tinyAVR, UNI/O, and XMEGA are registered trademarks of Microchip Technology Incorporated in the U.S.A. and other countries.

ClockWorks, The Embedded Control Solutions Company, EtherSynch, Hyper Speed Control, HyperLight Load, IntelliMOS, mTouch, Precision Edge, and Quiet-Wire are registered trademarks of Microchip Technology Incorporated in the U.S.A.

Adjacent Key Suppression, AKS, Analog-for-the-Digital Age, Any Capacitor, AnyIn, AnyOut, BodyCom, chipKIT, chipKIT logo, CodeGuard, CryptoAuthentication, CryptoCompanion, CryptoController, dsPICDEM, dsPICDEM.net, Dynamic Average Matching, DAM, ECAN, EtherGREEN, In-Circuit Serial Programming, ICSP, Inter-Chip Connectivity, JitterBlocker, KlearNet, KlearNet logo, Mindi, MiWi, motorBench, MPASM, MPF, MPLAB Certified logo, MPLIB, MPLINK, MultiTRAK, NetDetach, Omniscient Code Generation, PICDEM, PICDEM.net, PICKit, PICTail, PureSilicon, QMatrix, RightTouch logo, REAL ICE, Ripple Blocker, SAM-ICE, Serial Quad I/O, SMART-I.S., SQI, SuperSwitcher, SuperSwitcher II, Total Endurance, TSHARC, USBCheck, VariSense, ViewSpan, WiperLock, Wireless DNA, and ZENA are trademarks of Microchip Technology Incorporated in the U.S.A. and other countries.

SQTP is a service mark of Microchip Technology Incorporated in the U.S.A.

Silicon Storage Technology is a registered trademark of Microchip Technology Inc. in other countries.

GestIC is a registered trademark of Microchip Technology Germany II GmbH & Co. KG, a subsidiary of Microchip Technology Inc., in other countries.

All other trademarks mentioned herein are property of their respective companies.

© 2017, Microchip Technology Incorporated, All Rights Reserved.
ISBN: 978-1-5224-1530-5



MICROCHIP

Worldwide Sales and Service

AMERICAS

Corporate Office
2355 West Chandler Blvd.
Chandler, AZ 85224-6199
Tel: 480-792-7200
Fax: 480-792-7277
Technical Support:
<http://www.microchip.com/support>
Web Address:
www.microchip.com

Atlanta
Duluth, GA
Tel: 678-957-9614
Fax: 678-957-1455

Austin, TX
Tel: 512-257-3370

Boston
Westborough, MA
Tel: 774-760-0087
Fax: 774-760-0088

Chicago
Itasca, IL
Tel: 630-285-0071
Fax: 630-285-0075

Dallas
Addison, TX
Tel: 972-818-7423
Fax: 972-818-2924

Detroit
Novi, MI
Tel: 248-848-4000

Houston, TX
Tel: 281-894-5983

Indianapolis
Noblesville, IN
Tel: 317-773-8323
Fax: 317-773-5453
Tel: 317-536-2380

Los Angeles
Mission Viejo, CA
Tel: 949-462-9523
Fax: 949-462-9608
Tel: 951-273-7800

Raleigh, NC
Tel: 919-844-7510

New York, NY
Tel: 631-435-6000

San Jose, CA
Tel: 408-735-9110
Tel: 408-436-4270

Canada - Toronto
Tel: 905-695-1980
Fax: 905-695-2078

ASIA/PACIFIC

Asia Pacific Office
Suites 3707-14, 37th Floor
Tower 6, The Gateway
Harbour City, Kowloon

Hong Kong
Tel: 852-2943-5100
Fax: 852-2401-3431

Australia - Sydney
Tel: 61-2-9868-6733
Fax: 61-2-9868-6755

China - Beijing
Tel: 86-10-8569-7000
Fax: 86-10-8528-2104

China - Chengdu
Tel: 86-28-8665-5511
Fax: 86-28-8665-7889

China - Chongqing
Tel: 86-23-8980-9588
Fax: 86-23-8980-9500

China - Dongguan
Tel: 86-769-8702-9880

China - Guangzhou
Tel: 86-20-8755-8029

China - Hangzhou
Tel: 86-571-8792-8115
Fax: 86-571-8792-8116

China - Hong Kong SAR
Tel: 852-2943-5100
Fax: 852-2401-3431

China - Nanjing
Tel: 86-25-8473-2460
Fax: 86-25-8473-2470

China - Qingdao
Tel: 86-532-8502-7355
Fax: 86-532-8502-7205

China - Shanghai
Tel: 86-21-3326-8000
Fax: 86-21-3326-8021

China - Shenyang
Tel: 86-24-2334-2829
Fax: 86-24-2334-2393

China - Shenzhen
Tel: 86-755-8864-2200
Fax: 86-755-8203-1760

China - Wuhan
Tel: 86-27-5980-5300
Fax: 86-27-5980-5118

China - Xian
Tel: 86-29-8833-7252
Fax: 86-29-8833-7256

ASIA/PACIFIC

China - Xiamen
Tel: 86-592-2388138
Fax: 86-592-2388130

China - Zhuhai
Tel: 86-756-3210040
Fax: 86-756-3210049

India - Bangalore
Tel: 91-80-3090-4444
Fax: 91-80-3090-4123

India - New Delhi
Tel: 91-11-4160-8631
Fax: 91-11-4160-8632

India - Pune
Tel: 91-20-3019-1500

Japan - Osaka
Tel: 81-6-6152-7160
Fax: 81-6-6152-9310

Japan - Tokyo
Tel: 81-3-6880-3770
Fax: 81-3-6880-3771

Korea - Daegu
Tel: 82-53-744-4301
Fax: 82-53-744-4302

Korea - Seoul
Tel: 82-2-554-7200
Fax: 82-2-558-5932 or
82-2-558-5934

Malaysia - Kuala Lumpur
Tel: 60-3-6201-9857
Fax: 60-3-6201-9859

Malaysia - Penang
Tel: 60-4-227-8870
Fax: 60-4-227-4068

Philippines - Manila
Tel: 63-2-634-9065
Fax: 63-2-634-9069

Singapore
Tel: 65-6334-8870
Fax: 65-6334-8850

Taiwan - Hsin Chu
Tel: 886-3-5778-366
Fax: 886-3-5770-955

Taiwan - Kaohsiung
Tel: 886-7-213-7830

Taiwan - Taipei
Tel: 886-2-2508-8600
Fax: 886-2-2508-0102

Thailand - Bangkok
Tel: 66-2-694-1351
Fax: 66-2-694-1350

EUROPE

Austria - Wels
Tel: 43-7242-2244-39
Fax: 43-7242-2244-393

Denmark - Copenhagen
Tel: 45-4450-2828
Fax: 45-4485-2829

Finland - Espoo
Tel: 358-9-4520-820

France - Paris
Tel: 33-1-69-53-63-20
Fax: 33-1-69-30-90-79

France - Saint Cloud
Tel: 33-1-30-60-70-00

Germany - Garching
Tel: 49-8931-9700

Germany - Haan
Tel: 49-2129-3766400

Germany - Heilbronn
Tel: 49-7131-67-3636

Germany - Karlsruhe
Tel: 49-721-625370

Germany - Munich
Tel: 49-89-627-144-0
Fax: 49-89-627-144-44

Germany - Rosenheim
Tel: 49-8031-354-560

Israel - Ra'anana
Tel: 972-9-744-7705

Italy - Milan
Tel: 39-0331-742611
Fax: 39-0331-466781

Italy - Padova
Tel: 39-049-7625286

Netherlands - Drunen
Tel: 31-416-690399
Fax: 31-416-690340

Norway - Trondheim
Tel: 47-7289-7561

Poland - Warsaw
Tel: 48-22-3325737

Romania - Bucharest
Tel: 40-21-407-87-50

Spain - Madrid
Tel: 34-91-708-08-90
Fax: 34-91-708-08-91

Sweden - Gothenberg
Tel: 46-31-704-60-40

Sweden - Stockholm
Tel: 46-8-5090-4654

UK - Wokingham
Tel: 44-118-921-5800
Fax: 44-118-921-5820