

# Monitored Ethernet Switches

## 10 & 18 port, SNMP, Modbus/TCP

### Models SEC310-2SFP-T, SEC318-2SFP-T



SEC310-2SFP-T



SEC318-2SFP-T



### Features & Benefits

- Communicates with HMI/SCADA software via Modbus/TCP
- Integrated with iView<sup>2</sup>™ - SNMP Management Software (free download)
- Energy Efficient Ethernet (EEE), IEEE 802.3az for low energy consumption
- Wide temperature range -40 to 75°C
- DIN rail or wall/panel mountable
- Redundant dual 12 to 48 VDC power inputs
- EMS Level 3 Protection
- Designed for hazardous locations: UL C1D2, ATEX Zone 2 (pending), IECEx (pending)
- Port-based QoS feature for deterministic data transmission
- Loop detection and event alarm
- Power failure indicated by a relay and LED indicator

### Introduction

SE300 series is the industry's first design for Ethernet Green®, IEEE802.3az - Energy Ethernet switches that cut power usage by up to 60%, significantly saving energy usage in the field and reducing total cost of ownership over 24/7.

Advantech B+B SmartWorX SE300 series monitored switches can be used as plug-and-play unmanaged switches right out of the box. Installing the iView<sup>2</sup> Network Management Software gives them basic monitoring and management capabilities as well. They bridge the gap between unmanaged switches and significantly more expensive, fully managed solutions.

When enabled with iView<sup>2</sup>, these switches provide IP address assignment, allowing for a static IP address or an address that is discoverable via DHCP in the network. Then, these switches have the ability to use Modbus/TCP to communicate with HMI/SCADA software and SNMP to communicate with NMS (Networking Management Software) at the same time. This gives full access control to both control engineers and IT managers.

### Basic Monitoring & Management Capabilities

iView<sup>2</sup> gives network managers the ability to monitor and manage eWorX SE300 series switches from a central location. It features an intuitive Graphical User Interface (GUI) that provides a real-life representation of all installed eWorX SE300 Series switches, displaying device functions, port settings, device status information and traffic statistics via SNMP.

iView<sup>2</sup> can also configure eWorX SE300 series switches monitoring capabilities for automation applications via the popular Modbus TCP/IP protocol. Control engineers can use existing HMI/SCADA software to integrate the network status by creating extra tags for real-time monitoring. iView<sup>2</sup> is a standalone software that supports multiple platforms and operating systems.

### iView<sup>2</sup> Features for eWorX SE300 series Switches

#### Monitoring:

- System information (IP/MAC address)
- Port status
- Port speed
- Flow control
- Link up counter
- TX packets counter, RX packets counter
- TX error packets counter, RX error packets counter
- Firmware version
- PoE status (PoE model/s only)

#### Management:

- Configure IP mode
- Set IP address
- Set TCP Modbus/TCP time-out
- Create Community Strings
- Configure Traps

### Specifications

COMMUNICATIONS	
Standards	IEEE 802.3, 802.3u, 802.3x, 802.3ab, 802.3z, 802.1p, 802.3az
LAN	10/100/1000Base-T(X), Optional 100Base-FX, 1000Base-SX/LX/LHX/XD/ZX/EZX
Transmission Distance	Ethernet: 100m (4-wire Cat.5e, Cat.6 RJ-45 cable suggested for Gigabit port) SFP: 110km (depends on SFP)
Transmission Speed	Ethernet: 10/100Mbps Auto-Negotiation Gigabit Copper: 10/100/1000Mbps, Auto-Negotiation Gigabit Fiber: Up to 1000Mbps
INTERFACE	
Connectors	SEC310-2SFP-T: 8 x RJ45 + 2 x (RJ45/SFP) combo ports SEC318-2SFP-T: 16 x RJ45 + 2 x (RJ45/SFP) combo ports 6-pin removable screw terminal (power & relay)
Ethernet	Auto Sensing, 10/100/1000BaseTX, Duplex and MDIX.
LED Indicators	P1, P2, P-Fail, Loop Detection 10/100T(X): Link/Activity, Speed Gigabit Copper: Link/Activity, Speed (1000 Mbps) SFP: Link/Activity

# Monitored Ethernet Switches 10 & 18 port, SNMP, Modbus/TCP

Models SEC310-2SFP-T, SEC318-2SFP-T

## Specifications - continued

SWITCH PROPERTIES	
MAC Table Size	8k
Packet Buffer Size	4.1M bit
Switching Capacity	SEC310-2SFP-T: 5.6 Gbps. SEC318-2SFP-T: 7.2 Gbps
Jumbo Frame	9126 bytes
POWER	
Power Consumption	SEC310-2SFP-T: Max. 5.8W. SEC318-2SFP-T: Max. 8.2W
Power Input	12~48 VDC (8.4~52.8VDC) redundant dual inputs
Fault Output	1 Relay Output
Reverse Polarity Protection	Present
Overload Current	Present
PHYSICAL	
Dimensions (WxHxD)	74 x 120 x 84 mm
Enclosure	IP30, metal shell with solid mounting kits
Mounting	DIN-Rail, Wall

## Specifications - continued

ENVIRONMENT	
Operating Temperature	-40 ~ 75°C (-40 ~ 167°F)
Storage Temperature	-40 ~ 85°C (-40 ~ 185°F)
Operating Humidity	10 ~ 95% (non-condensing)
Storage Humidity	10 ~ 95% (non-condensing)
MTBF	SEC310-2SFP-T: 3,183,604 hours SEC318-2SFP-T: 2,825,281 hours
CERTIFICATIONS	
Hazardous Environments	UL Class 1 Division 2 Groups A,B,C,D; ATEX Zone 2 (pending); IECEx (pending)
Safety	UL508
EMI	FCC Part 15 Subpart B Class A, EN 55011/55022, Class A
EMS	EN 61000-4-2 (Level 3), EN 61000-4-3 (Level 3) EN 61000-4-4 (Level 3), EN 61000-4-5 (Level 3) EN 61000-4-6 (Level 3), EN 61000-4-8 (Level 3)
Shock	IEC 60068-2-27
Freefall	IEC 60068-2-32
Vibration	IEC 60068-2-6

## SOFTWARE

Management	iView <sup>2</sup> , LLDP, SNMP v1/v2c, Modbus/TCP
Configuration	Static IP address, DHCP Client
Monitoring	Port Statistics (Speed/Status), Link Up/Down counter, Error Packet counter, Loop detection
Filter	Flow control, IEEE 802.1p QoS(Strict mode), Broadcast storm protection
Industrial Profiles	Modbus/TCP profiles included - Configuration and Diagnostic via automation software tools like e.g. Wonderware InTouch, STEP7, InduSoft Web Studio

## IVIEW<sup>2</sup> - NETWORK MANAGEMENT SOFTWARE - FREE DOWNLOAD

Version	iView <sup>2</sup> Web-based Application
OS Support	32-bit/64-bit Windows XP/Vista/7, Windows Server 2003/2008/2008 R2
Operation Modes	Local Computer or Remote Server
Web Browser	Microsoft® IE, Chrome, Firefox
Protocol	SNMPv1 and SNMPv2c

## Product Ordering Information

MODEL #	DESCRIPTION	OPERATING TEMPERATURE	RJ45				FIBER			
			10/100 MBPS	GIGABIT	100FX	100/1000BASE-SFP	COMBO PORT, 10/100/1000BASE-T(X) OR 100/1000BASE-SFP	TYPE	CONNECTOR	
SEC310-2SFP-T	8-port 10/100Mbps + 2-port GbE Combo Monitored Ethernet Switch	-40~75°C	8	-	-	-	-	2	-	LC (SFP)
SEC318-2SFP-T	16-port 10/100Mbps + 2-port GbE Combo Monitored Ethernet Switch	-40~75°C	16	-	-	-	-	2	-	LC (SFP)

## Accessories - optional

MODEL #	DESCRIPTION
MDR-40-24	DIN Rail Power supply, 24VDC 40 Watt
CSUMB3FBG	3 ft. (1 M), Gray, Category 5e UTP Patch Cord
CSUMB7FBG	7 ft. (2 M), Gray, Category 5e UTP Patch Cord
808-38102	IE-SFP 100 to 155 Mbps (OC-3), MM850-LC, 2km
808-38104	IE-SFP 100 to 155 Mbps (OC-3), SM1310/PLUS-LC, 40km
808-38200	IE-SFP 1250 Mbps to 1.25 Gbps (OC-24), SM1310-LC, 20km
808-38201	IE-SFP 1250 Mbps to 1.25 Gbps (OC-24), MM850-LC, 2250/550m
808-38203	IE-SFP 1250 Mbps to 1.25 Gbps (OC-24), SM1310/PLUS-LC, 30km

## Package Checklist

Ethernet Switch, Quick Start Guide, DIN-Rail mount bracket (installed), Wall mount bracket

## Warranty

Limited lifetime warranty for Advantech B+B designed and/or manufactured products.

## Model SEC310-2SFP-T Mechanical Diagram | DIN Rail & Wall Mount Options

Units = [inches] mm

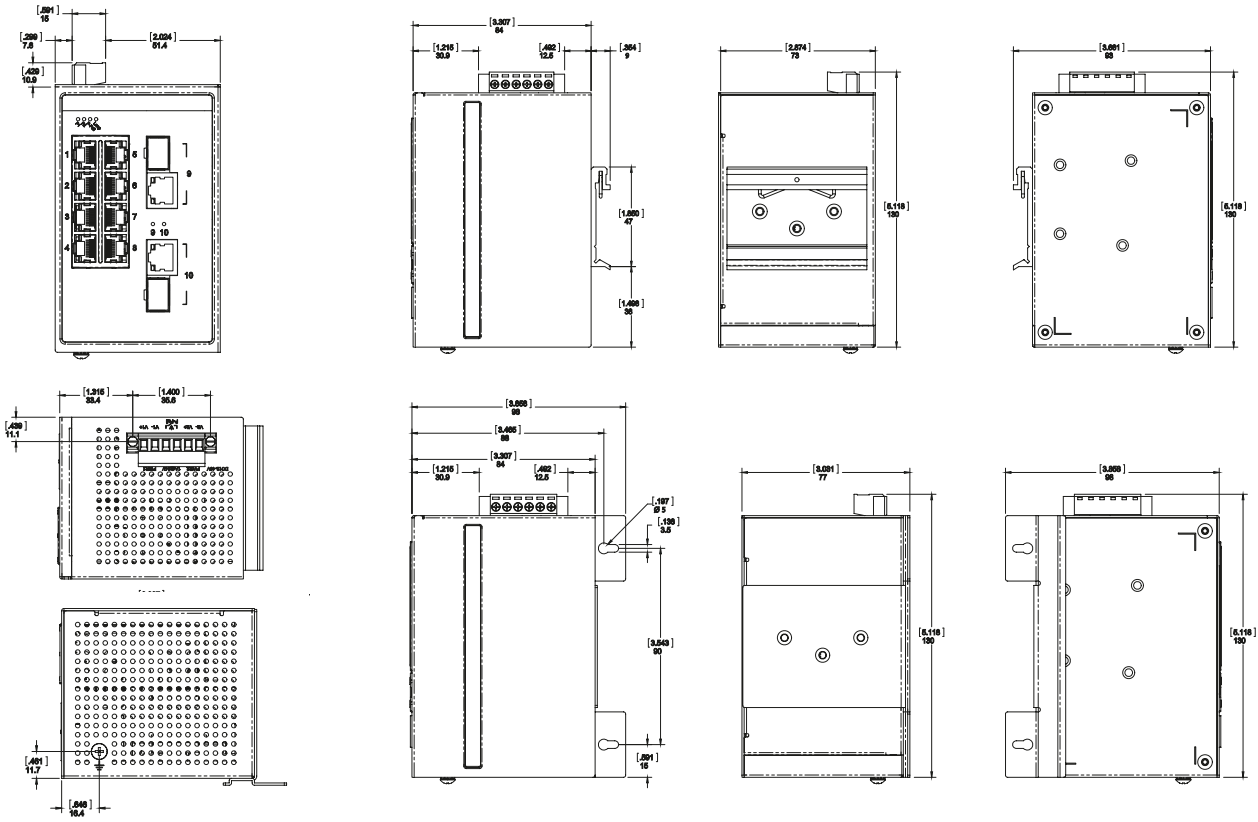

## Model SEC318-2SFP-T Mechanical Diagram | DIN Rail & Wall Mount Options

Units = [inches] mm

