

T H E R M O M E T R I C S
A C O M M I T M E N T T O E X C E L L E N C E

Exhaust Gas High Temperature Sensor



This sensor operates over a temperature range from -40°C to 850°C . It monitors the temperature before and after SCR system in the diesel engines as part of the engine control strategy. It is designed for fast response, optimized for thermal dissipation and suitable for high vibration and corrosive environments.

Applications

- Gasoline or Diesel engines
- Exhaust gas
- SCR
- Aerospace

Features

- 1000°C PT200 RTD element
- Survives excursions to 1000°C
- Highly resistant to corrosive exhaust gases
- Long-term stability
- Extended life from moisture-proof design
- Design optimized for heat transfer
- High 3 % accuracy
- Flexible Pigtail Connector
- Customizable hex dimensions and thread type
- Alternate 1% accuracy RTD element available

Amphenol
Advanced Sensors

Exhaust Gas High Temperature Sensor NTC

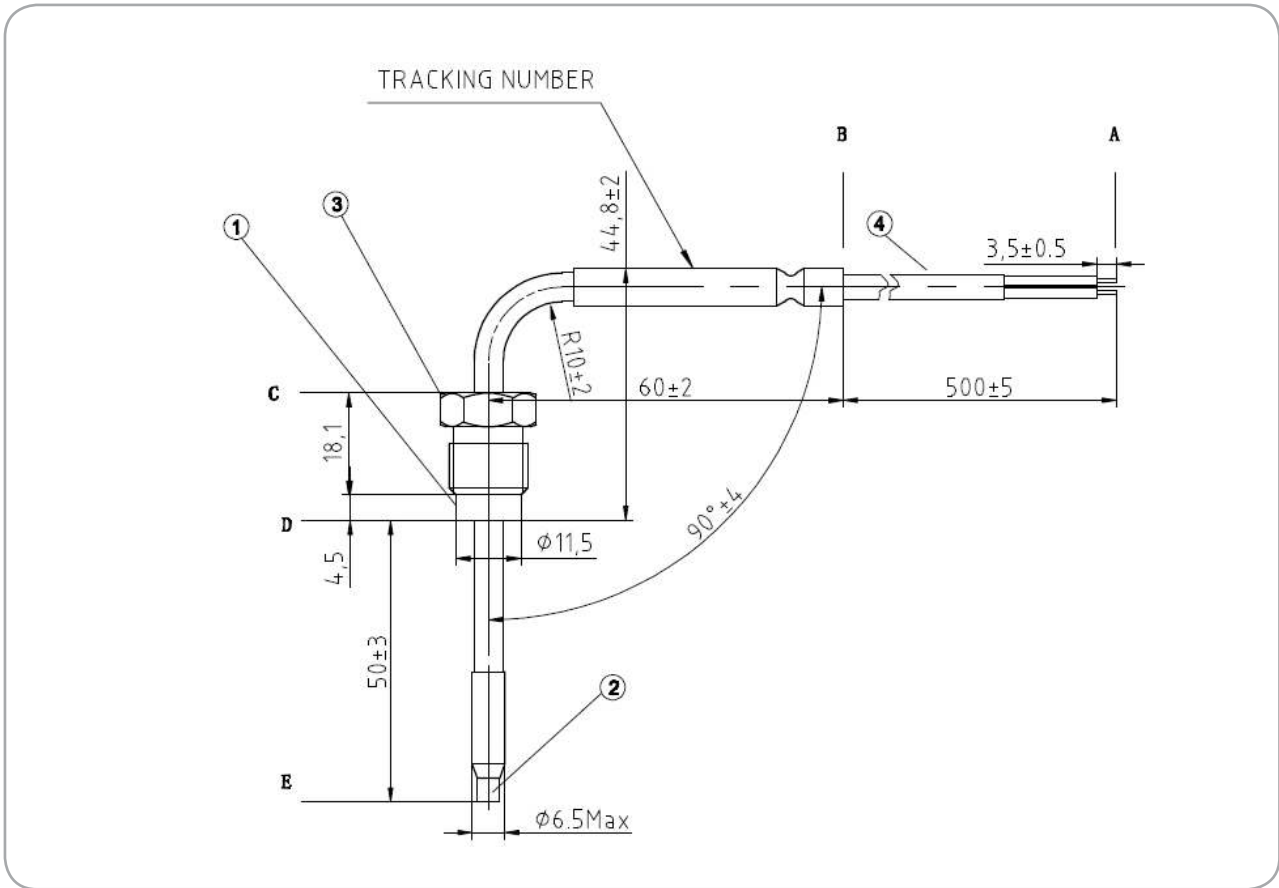

Typical Application Circuit

Supply Voltage: $U_p = 5V$
 Resistance: $R_p = 1000 \text{ Ohm}$
 Lead resistance: $R_1 = 1.0 \text{ Ohm}$
 Max current: 2.7 mA

RvT Table

T (°C)	Rs (Ohms)	U0	*Δ Rs (Ohms)
-40	170.2	0.73	±3.49
0	201	0.84	±3.45
25	220.1	0.9	±3.42
50	239	0.96	±3.39
100	276.4	1.08	±3.34
200	349.5	1.29	±3.23
300	420.2	1.48	±3.13
400	488.6	1.64	±4.0
500	554.6	1.78	±4.84
600	618.3	1.91	±5.61
700	679.7	2.02	±6.3
800	738.7	2.12	±6.92
850	767.3	2.17	±7.21

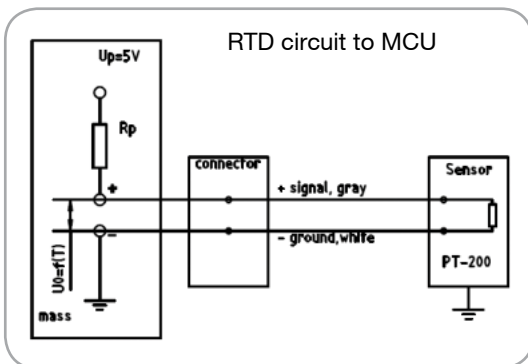

Exhaust Gas High Temperature Sensor Specifications

Operating Temperature

-40 to 850°C

Survives short (under 1 hour) excursions to 1000°C

Storage Temperature

-40 to 125°C

Response Time

$T_{63} = 3.5s$ (400°C Salt bath)

Temperature Accuracy

$\pm 4.5^\circ\text{C}$ from - 40 °C ~ 300 °C

$\pm 1.5\%$ from 300 °C ~ 850 °C

Housing Material

304 Series Stainless Steel

Thread Designation

M14 × 1.5

Weight

52 grams

Connector

Connector house type: AMP 282104-1

Connector pin type: AMP 282404-3

Mating Connector

Mating connector house type: AMP 282080-1

Mating Terminal type: AMP 282403-1

Max 60 N pull force to connector

Recommended Mounting Torque

45+/- 5 N*M

Ordering Code for Standard Product : CTTS-186019-F02A

* Other configurations available on request

Mounting Boss

