



162 MHz Crystal Bandpass Filter

Part Number: AM162CR349

Center Frequency (Fo):	162 MHz
3 dBc Bandwidth:	80 KHz Min
Insertion Loss:	4 dB Min
Passband Ripple:	0.5 dB max
60dBc Min at: Target 70 to 80 dB	162.4 MHz
Impedance:	50 Ohms
Operating Temperature:	-20 to 70 deg. C
Workmanship:	IPC-610 Class 2
RoHS COMPLIANT:	NO

Outline Drawing:

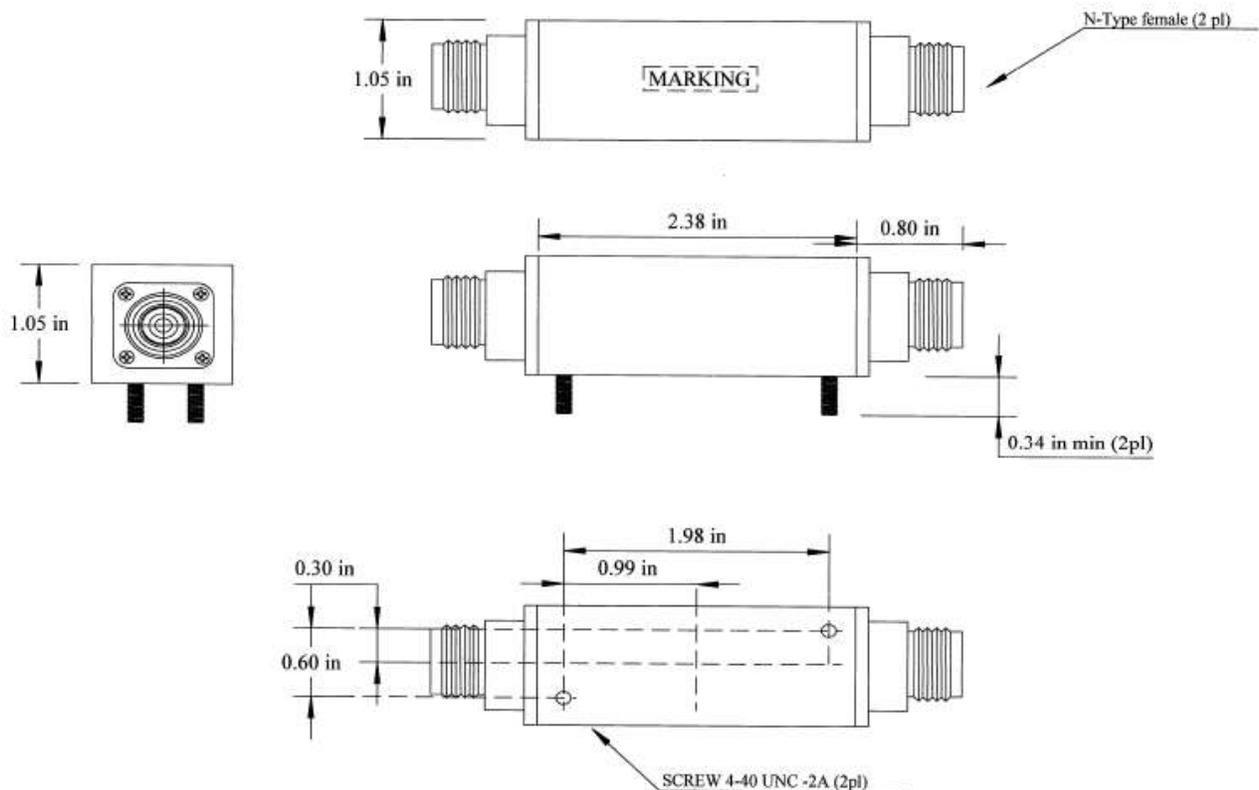

TOL: xx- .020
xxx- .005



162 MHz Crystal Bandpass Filter

Part Number: AM162CR349

Response Plot:

