

MATERIALS AND FINISHES

BODY CONTACT BRASS  
PLATED GOLD

INSULATOR TEFLON

SNAP RING BERYLLIUM COPPER  
PLATED GOLD

PACKING BY TAPE&REEL

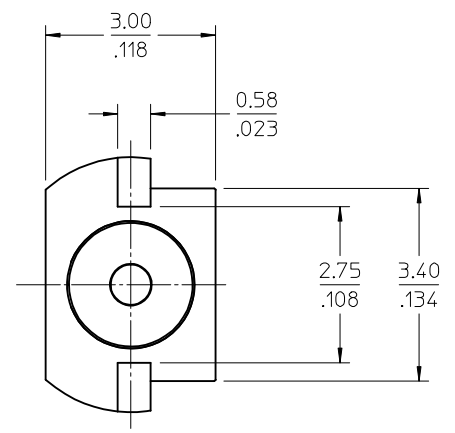
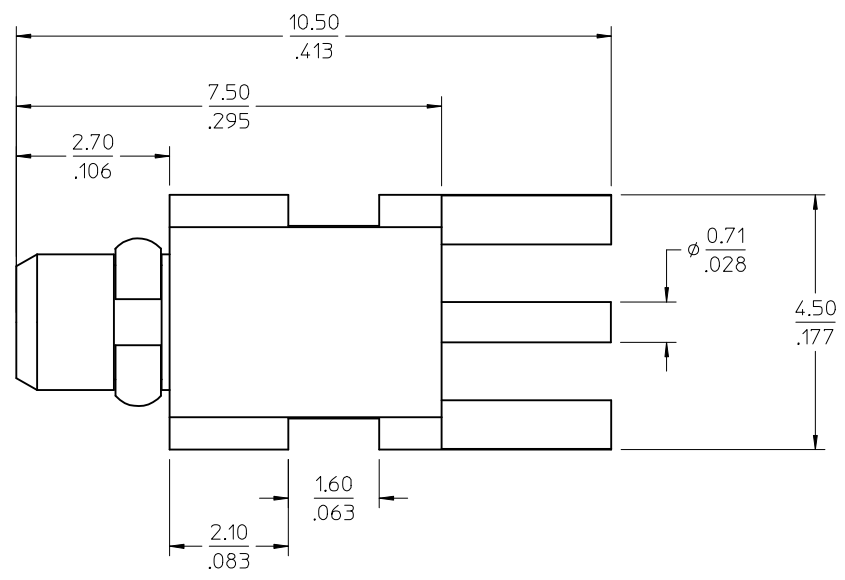
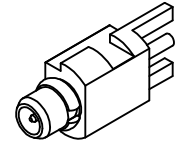

ES-73599-0000-0150	INTERFACE
PS-89675-1910	PRODUCT SPEC
SPECIFICATION	DESCRIPTION

73415-1271	PER COMMERCIAL REQUIREMENTS
73415-1270	PER MILITARY REQUIREMENTS
PART NO.	DESCRIPTION

CHGADD T&R DWG PER PDR13061353 EC No: DRF 2013-0715 DRAWN: CHENG 2013/06/21 CHKD: APPR: MHUANG 2013/06/21 D2	QUALITY SYMBOLS	GENERAL TOLERANCES (UNLESS SPECIFIED)	DIMENSION STYLE	SCALE	DESIGN UNITS	THIRD ANGLE PROJECTION
	▽=0	4 PLACES ± --- ± ---	MM/IN		METRIC	
	▽=0	3 PLACES ± --- ± ---				
	▽=0	2 PLACES ± --- ± ---				

DRAWN BY: YCHENG 2013/06/18 CHECKED BY: KERRIE 2013/06/19 APPROVED BY: MHUANG 2013/06/21	TITLE: MMCX, PLUG 50 OHM EDGE LAUNCHER MMCX-P/PCB <b>molex</b>	SHEET NO. 1 OF 3
MATERIAL NO. SEE TABLE DOCUMENT NO. SD-73415-127		
DRAFT WHERE APPLICABLE MUST REMAIN WITHIN DIMENSIONS		
THIS DRAWING CONTAINS INFORMATION THAT IS PROPRIETARY TO MOLEX INCORPORATED AND SHOULD NOT BE USED WITHOUT WRITTEN PERMISSION		

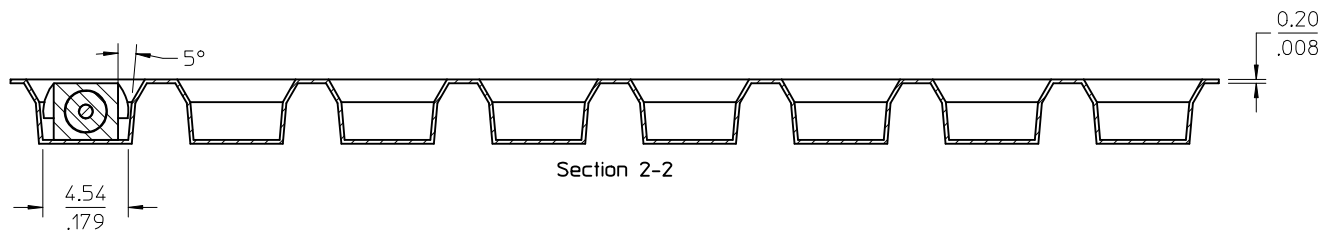
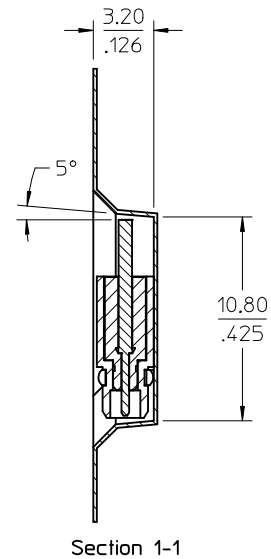
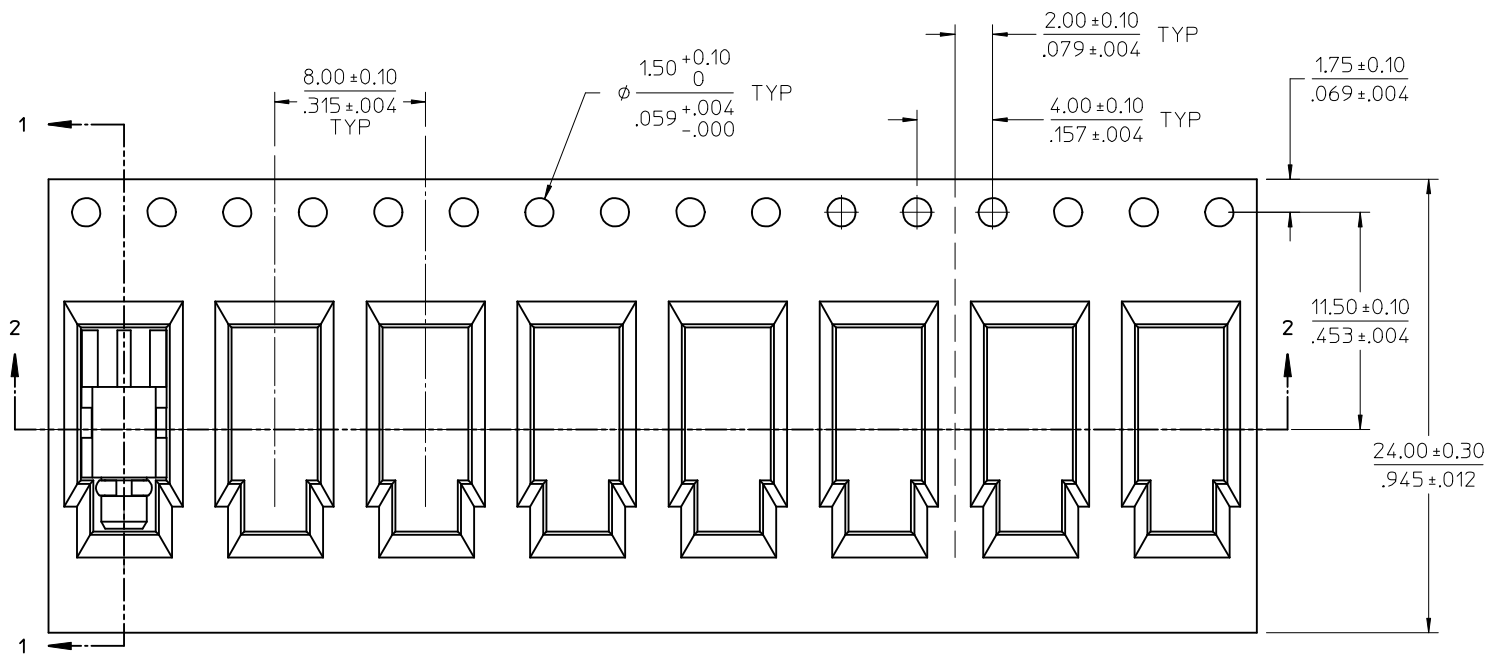

CHG:SEE SHEET1 EC NO: URF2013-0715 DRAWN:YCHENG 2013/06/21 CHKD: APPR:MHUANG 2013/06/21 REV: D2	QUALITY SYMBOLS $\nabla = 0$ $\nabla = 0$ $\nabla = 0$	GENERAL TOLERANCES (UNLESS SPECIFIED)		DIMENSION STYLE <b>MM/IN</b>	SCALE METRIC	DESIGN UNITS METRIC	THIRD ANGLE PROJECTION		
		4 PLACES ± --- ± --- 3 PLACES ± --- ± --- 2 PLACES ± --- ± --- 1 PLACE ± --- ± --- 0 PLACE ± --- ± ---	mm INCH	DRAWN BY YCHENG	DATE 2013/06/18	TITLE <b>MMCX, PLUG 50 OHM          EDGE LAUNCHER          MMCX-P/PCB</b>			
		ANGULAR ± 2°		CHECKED BY KERRIE	DATE 2013/06/19	<b>molex</b>			
		DRAFT WHERE APPLICABLE MUST REMAIN WITHIN DIMENSIONS		APPROVED BY MHUANG	DATE 2013/06/21	MATERIAL NO. <b>SEE SHEET1</b>	DOCUMENT NO. <b>SD-73415-127</b>	SHEET NO. <b>2 OF 3</b>	

THIS DRAWING CONTAINS INFORMATION THAT IS PROPRIETARY TO MOLEX INCORPORATED AND SHOULD NOT BE USED WITHOUT WRITTEN PERMISSION

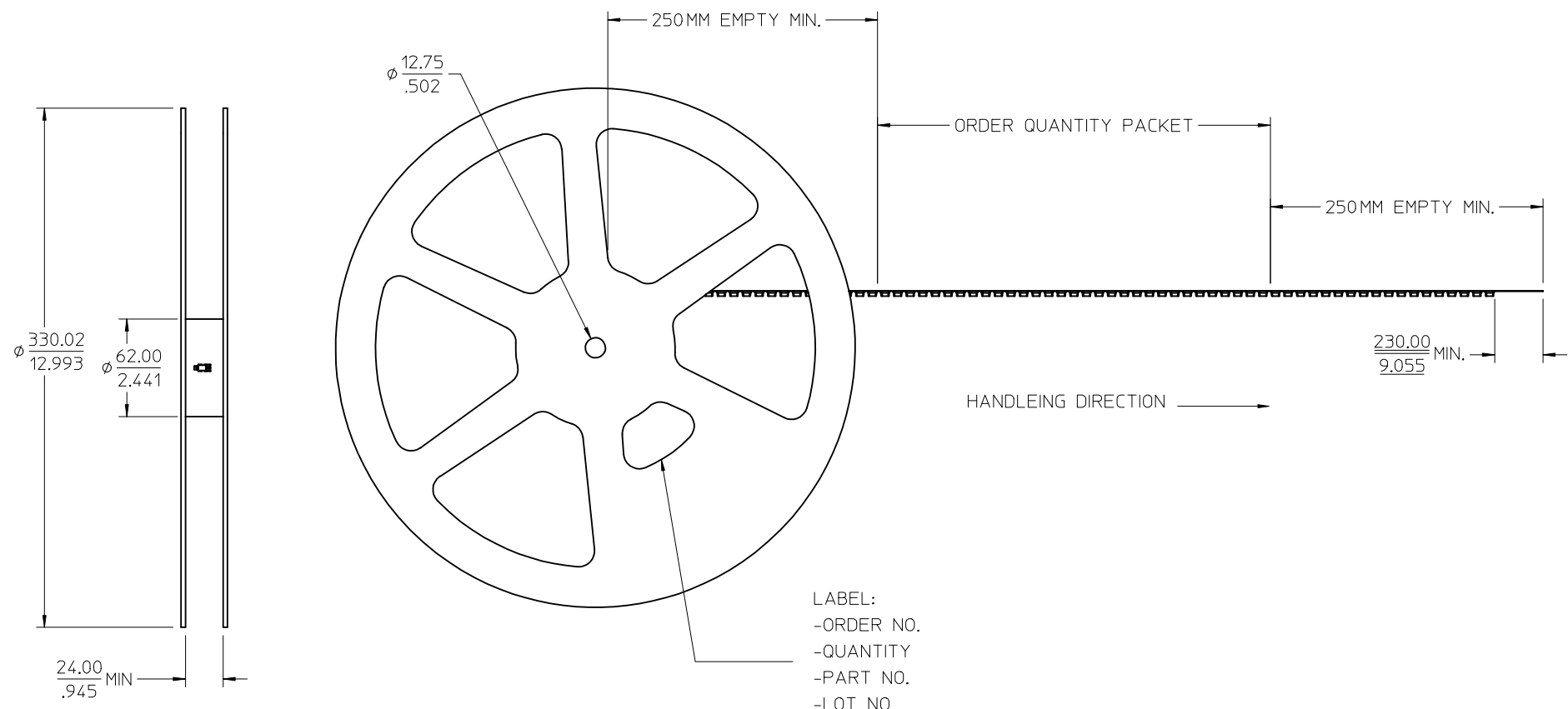

LABEL:  
 -ORDER NO.  
 -QUANTITY  
 -PART NO.  
 -LOT NO.

- PACKING DESCRIPTION:
1. MATERIAL:PS BLACK THICKNESS 0.4MM
  2. PACKING LENGTH PER 22" REEL : 62 METERS(1;3)
  3. COMPONENT LOAD PER 13" REEL : 2500 PCS
  4. DIMENSION ARE ROVIDED FOR REFERANCE ONLY

CHG:SEE SHEET1 EC NO: URF2013-0715 DRAWN:YCHENG 2013/06/21 CHKD: APPR:MHUANG 2013/06/21	DESCRIPTION 2013/06/21	QUALITY SYMBOLS	GENERAL TOLERANCES (UNLESS SPECIFIED)	DIMENSION STYLE	SCALE	DESIGN UNITS	THIRD ANGLE PROJECTION
		▽=0	mm INCH	MM/IN	METRIC	☉	
		▽=0	4 PLACES ± --- ± ---	DRAWN BY DATE	TITLE		
		▽=0	3 PLACES ± --- ± ---	YCHENG 2013/06/18	MMCX, PLUG 50 OHM EDGE LAUNCHER MMCX-P/PCB		
		2 PLACES ± --- ± ---	CHECKED BY DATE				
		1 PLACE ± --- ± ---	KERRIE 2013/06/19				
		0 PLACE ± --- ± ---	APPROVED BY DATE				
			MHUANG 2013/06/21				
			ANGULAR ± 2 °	MATERIAL NO.	DOCUMENT NO.		SHEET NO.
			DRAFT WHERE APPLICABLE MUST REMAIN WITHIN DIMENSIONS	SEE SHEET1	SD-73415-127		3 OF 3
				SIZE C THIS DRAWING CONTAINS INFORMATION THAT IS PROPRIETARY TO MOLEX INCORPORATED AND SHOULD NOT BE USED WITHOUT WRITTEN PERMISSION			