

Longitudinal Grounding Series Fingerstock Gaskets

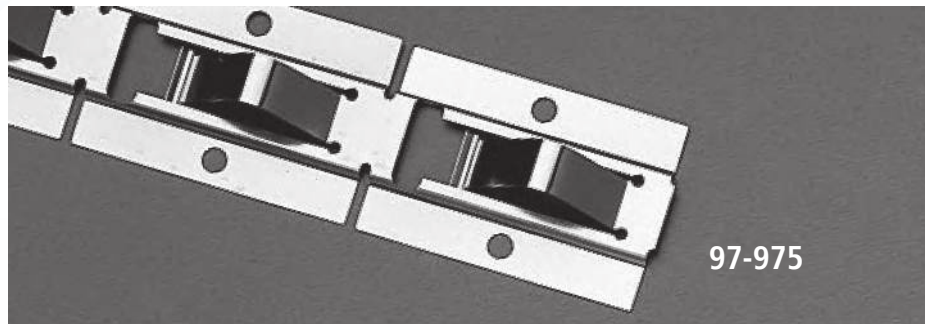

FINGERSTOCK GASKETS AND METAL GROUNDING PRODUCTS

As the world's leading fabricator of fingerstock, Laird Technologies has developed highly sophisticated, and often proprietary, shielding and grounding technology.

Our innovations are necessary to achieve outstanding combinations of performance parameters. From a vast selection of product configurations, platings and mounting techniques, to a full range of low compression force requirements and high transfer impedance characteristics, there is a Laird Technologies gasket or grounding product just right for the job.

This series of beryllium copper strips combines finger compression with the direction of motion in the longitudinal axis.

FEATURES

- Ideal for use with rack-mounted and slide drawer assemblies
- Provides reliable and complete grounds
- Typical installation methods include hardware mounting or use of the Sticky Fingers® self-adhesive strip
- Available in standard finishes
- Available in UltraSoft® low compression version (98-975).

global solutions: local support™

USA: +1.866.928.8181

Europe: +49.0.8031.2460.0

Asia: +86.755.2714.1166

Longitudinal Grounding Series Fingerstock Gaskets

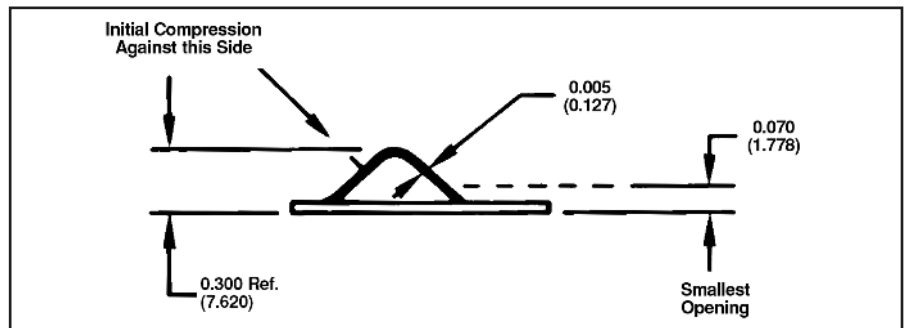
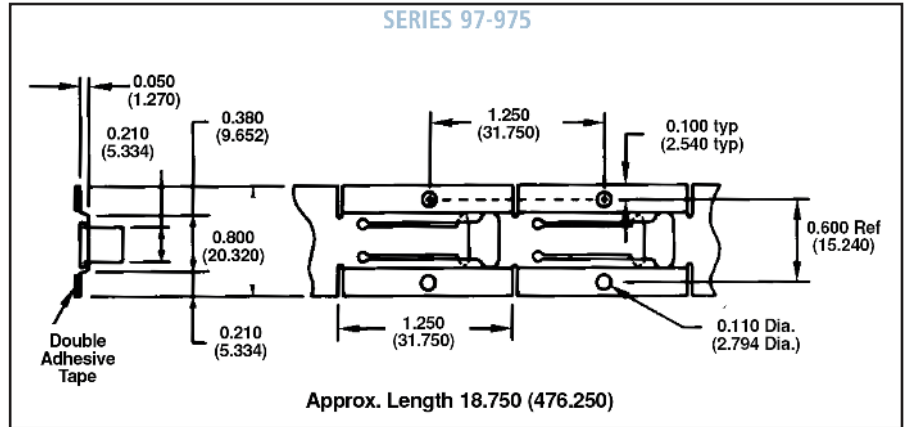

All dimensions shown are in inches (millimeters)
unless otherwise specified.

EMI-DS-FINGER-LONGITUDINAL 1112

Any information furnished by Laird Technologies, Inc. and its agents is believed to be accurate and reliable. All specifications are subject to change without notice. Responsibility for the use and application of Laird Technologies materials rests with the end user. Laird Technologies makes no warranties as to the fitness, merchantability, suitability or non-infringement of any Laird Technologies materials or products for any specific or general uses. Laird Technologies shall not be liable for incidental or consequential damages of any kind. All Laird Technologies products are sold pursuant to the Laird Technologies' Terms and Conditions of sale in effect from time to time, a copy of which will be furnished upon request. © Copyright 2012 Laird Technologies, Inc. All Rights Reserved. Laird, Laird Technologies, the Laird Technologies Logo, and other marks are trade marks or registered trade marks of Laird Technologies, Inc. or an affiliate company thereof. Other product or service names may be the property of third parties. Nothing herein provides a license under any Laird Technologies or any third party intellectual property rights.