

DRAWING MADE IN THIRD ANGLE PROJECTION

THIS DRAWING IS UNPUBLISHED. RELEASED FOR PUBLICATION . 19
COPYRIGHT 19 BY AMP INCORPORATED, HARRISBURG, PA. ALL INTERNATIONAL RIGHTS RESERVED. AMP PRODUCTS MAY BE COVERED BY U.S. AND FOREIGN PATENTS AND/OR PATENTS PENDING.

P		F		ZONES		LTR		DESCRIPTION		DATE	APPROVED
A				A				REV ECN AA-3439	12-4-86	SD	SD

D
C
B
A

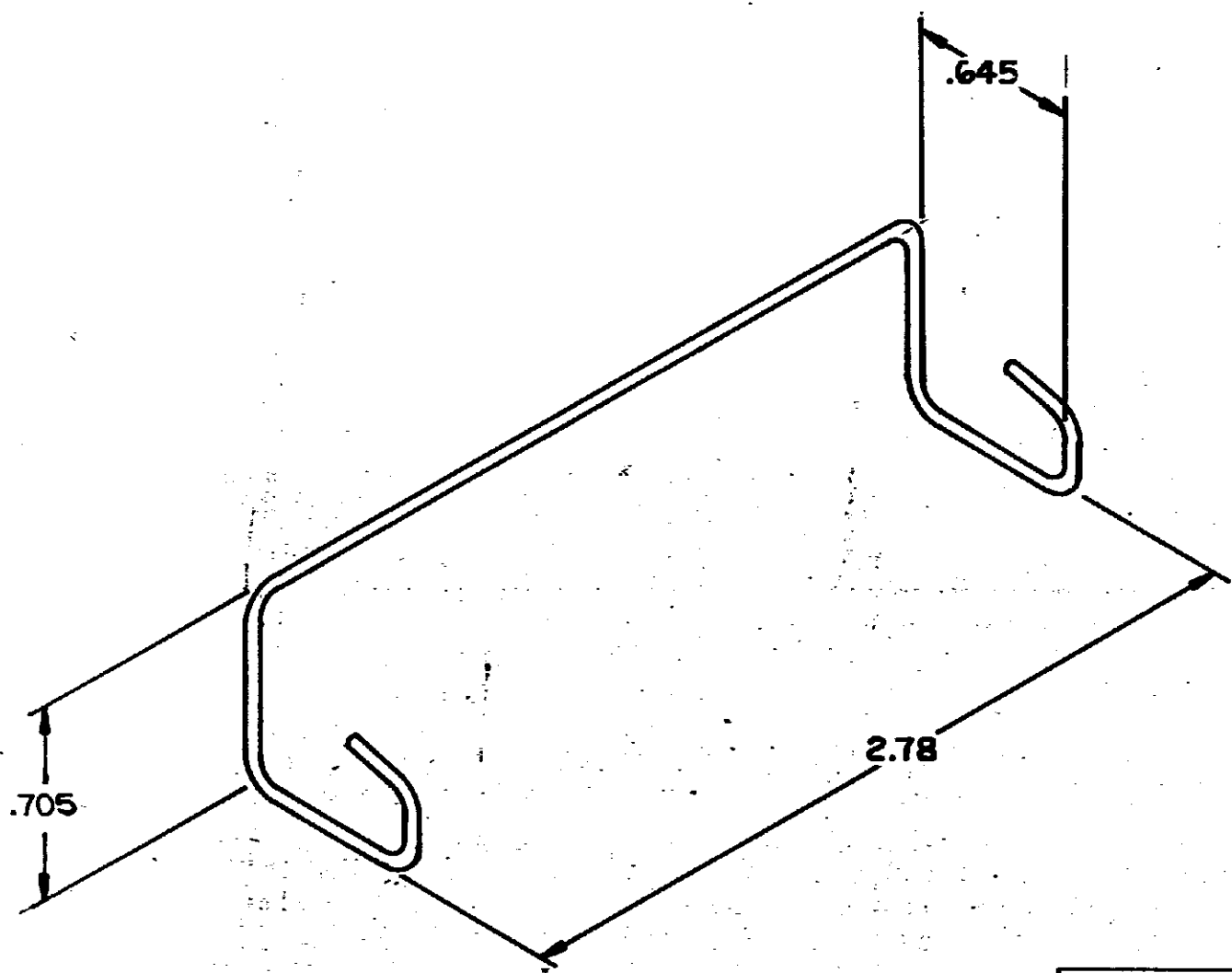

1. ALL DIMENSIONS SHOWN ARE MAXIMUM UNLESS OTHERWISE SPECIFIED.
 2 MATERIAL: STAINLESS STEEL WIRE, .050 DIA.

554099-1

UNLESS OTHERWISE SPECIFIED DIMENSIONS ARE IN INCHES. TOLERANCES ON: DECIMALS ± .005 ANGLES ± .5°		CONTRACT NO		AMP AMP INCORPORATED Harrisburg, Pa.	
MATERIAL		DR <i>A. Garty</i> 1/15/86		NAME	
FINISH		CHK <i>A. Fox</i> 1-16-86		CLIP, STRAIN RELIEF, FLAT CABLE, CHAMP LATCH	
		APPROV <i>[Signature]</i> 1-17-86		SIZE	FSCM NO
		DSGN APPD		B	00779
		OTHER APPD		DRAWING NO	
				554099	
				SCALE 2:1	SHEET 1 OF 1

AMP 1470-15 REV 2-81

CUSTOMER DRAWING