

Linear Single Cell Li-Ion Battery Charger with Auto Power Path Management

General Description

The RT9519B is an integrated single-cell Li-ion battery charger with auto power path management (APPM). No external MOSFETs are required. The RT9519B enters sleep mode when power is removed. Charging tasks are optimized by using a control algorithm to vary the charge rate, including pre-charge mode, fast charge mode and constant voltage mode. For the RT9519B, the charge current can also be programmed with an external resistor and modified with an external GPIO. The scope that the battery regulation voltage can be modified with an external GPIO depends on the battery temperature. The internal thermal feedback circuitry regulates the die temperature to optimize the charge rate for all ambient temperatures. The charging task will always be terminated in constant voltage mode when the charging current reduces to the termination current of 10% x ICHG_FAST. Other features include under voltage protection and over voltage protection for VIN supply.

Ordering Information

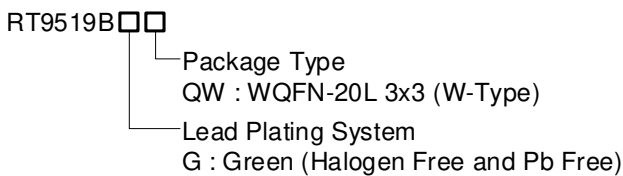

Note :

Richtek products are :

- ▶ RoHS compliant and compatible with the current requirements of IPC/JEDEC J-STD-020.
- ▶ Suitable for use in SnPb or Pb-free soldering processes.

Marking Information

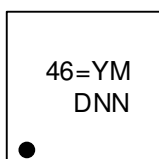

46= : Product Code
YMDNN : Date Code

Features

- 28V Maximum Rating for VIN Power
- Selectable Power Current Limit (0.1A / 0.5A / 1.5A)
- Integrated Power MOSFETs
- Auto Power Path Management (APPM)
- Battery Charging Current Control
- Battery Regulation Voltage Control
- Programmable Charging Current and Safe Charge Timer
- Under Voltage Protection, Over Voltage Protection
- Power Good and Charge Status Indicator
- Optimized Charge Rate via Thermal Feedback
- Thin 20-Lead WQFN Package
- RoHS Compliant and Halogen Free

Applications

- Digital Cameras
- PDAs and Smart Phones
- Portable Instruments

Pin Configuration

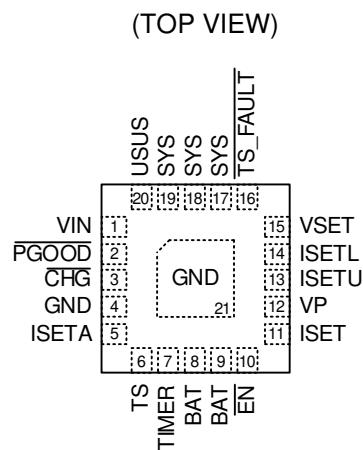

WQFN-20L 3x3

Typical Application Circuit

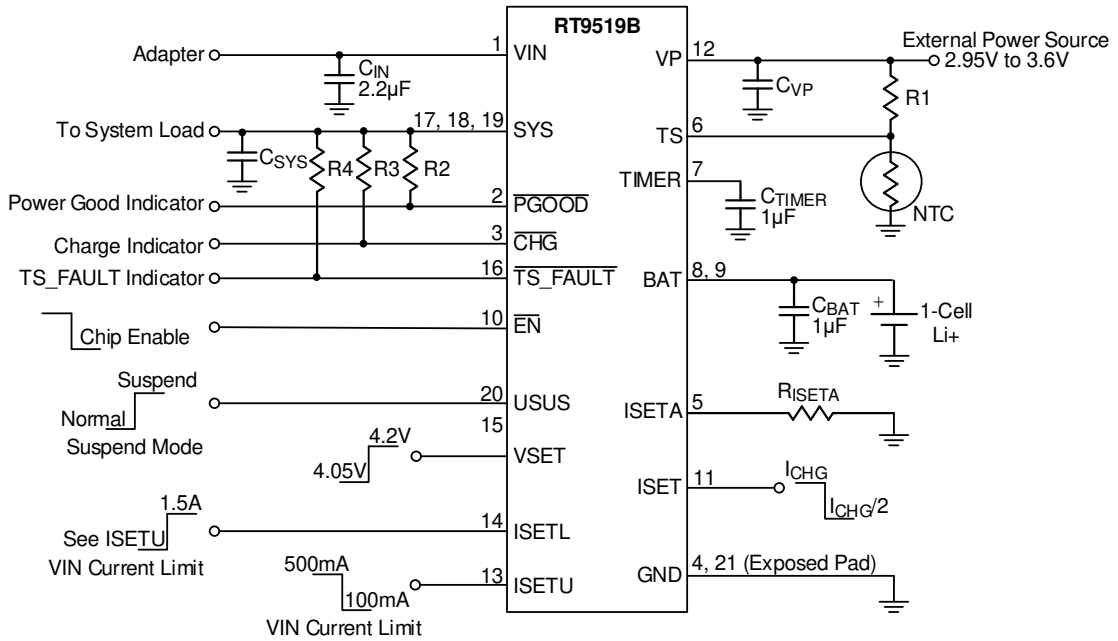

Functional Block Diagram

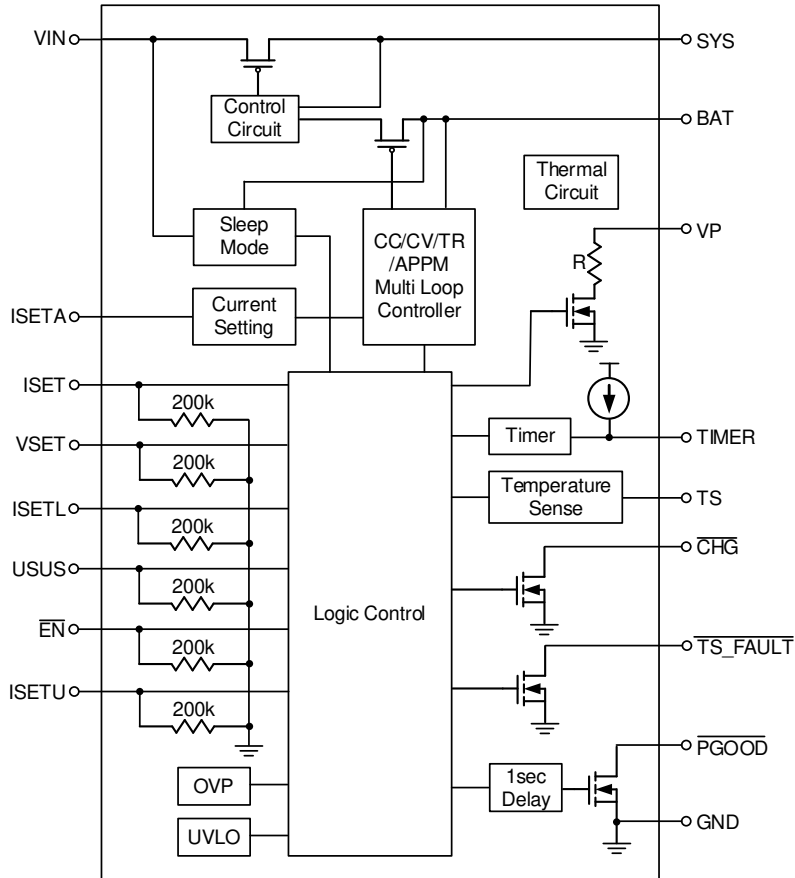

Functional Pin Description

| Pin No. | Pin Name | Pin Function |
|------------------------|-------------------------------|--|
| 1 | VIN | Supply voltage input. |
| 2 | $\overline{\text{PGOOD}}$ | Power good status output. Active low, open-drain output. |
| 3 | $\overline{\text{CHG}}$ | Charger status output. Active low, open-drain output. |
| 4, 21 (Exposed Pad) | GND | Ground. The exposed pad must be soldered to a large PCB and connected to GND for maximum power dissipation. |
| 5 | ISETA | Charge current set input. Connect a resistor (R_{ISETA}) between ISETA and GND. |
| 6 | TS | Temperature Sense Input. The TS pin connects to a battery's thermistor to determine if the battery is too hot or too cold to charge. If the battery's temperature is out of range, charging is paused until it re-enters the valid range. TS also detect battery (with NTC) is present or not. |
| 7 | TIMER | Safe charge timer setting. |
| 8, 9 | BAT | Battery charge current output. |
| 10 | $\overline{\text{EN}}$ | Charge enable. Active high input. 200k Ω pull low. |
| 11 | ISET | Half charge current set input. Control by external GPIO, L = ICHG1 / 2, H = ICHG1, 200k Ω pull low. |
| 12 | VP | This pin must be provided a regulated voltage from 2.95V to 3.6V by external power. |
| 13 | ISETU | VIN current limit control input. When $\overline{\text{ISETL}}$ = H, L = 100mA, H = 500mA, 200k Ω pull low. |
| 14 | $\overline{\text{ISETL}}$ | VIN current limit control input. H : see ISETU, L = 1.5A, 200k Ω pull low. |
| 15 | VSET | Battery regulation set input. Control by external GPIO. L = 4.05V, H = 4.2V, 200k Ω pull low. |
| 16 | $\overline{\text{TS_FAULT}}$ | TS fault status output. Open-drain output. If TS is of fault (too cold, too hot) or VP triggers UVLO, $\overline{\text{TS_FAULT}}$ = L. If TS and VP are normal, $\overline{\text{TS_FAULT}}$ = H. |
| 17, 18, 19 | SYS | System connect pin. Connect this pin to system with a minimum 10 μ F ceramic capacitor connected to GND. |
| 20 | USUS | VIN suspend control input. H = Suspend, L = No suspend. 200k Ω pull low. |

Absolute Maximum Ratings (Note 1)

- Supply Voltage, V_{IN} ----- -0.3V to 28V
- \overline{CHG} , \overline{PGOOD} ----- -0.3V to 28V
- Other Pins ----- -0.3V to 6V
- \overline{CHG} , \overline{PGOOD} Continuous Current ----- 20mA
- BAT Continuous Current (total in two pins) (Note 2) ----- 2.5A
- Power Dissipation, P_D @ $T_A = 25^\circ\text{C}$
 WQFN 20L 3x3 ----- 1.471W
- Package Thermal Resistance (Note 2)
 WQFN 20L 3x3, θ_{JA} ----- 68°C/W
 WQFN 20L 3x3, θ_{JC} ----- 7.5°C/W
- Lead Temperature (Soldering, 10sec.) ----- 260°C
- Junction Temperature ----- 150°C
- Storage Temperature Range ----- -65°C to 150°C
- ESD Susceptibility (Note 3)
 HBM (Human Body Model) ----- 2kV
 MM (Machine Model) ----- 200V

Recommended Operating Conditions (Note 4)

- Supply Input Voltage Range, V_{IN} ($\overline{ISETL} = L$) ----- 4.4V to 6V
- Supply Input Voltage Range, V_{IN} ($\overline{ISETL} = H$) ----- 4.5V to 6V
- Ambient Temperature Range ----- -40°C to 85°C
- Junction Temperature Range ----- -40°C to 125°C

Electrical Characteristics

($V_{IN} = 5\text{V}$, $V_{BAT} = 4\text{V}$, $T_A = 25^\circ\text{C}$, unless otherwise specified)

| Parameter | Symbol | Test Conditions | Min | Typ | Max | Unit |
|--------------------------------------|-------------------|--|-----|-----|-----|---------------|
| Supply Input | | | | | | |
| VIN Under Voltage Lockout Threshold | V_{UVLO} | $V_{IN} = 0\text{V}$ to 4V | 3.1 | 3.3 | 3.5 | V |
| VIN Under Voltage Lockout Hysteresis | ΔV_{UVLO} | $V_{IN} = 4\text{V}$ to 0V | -- | 240 | -- | mV |
| VIN Supply Current | I_{SUPPLY} | $I_{SYS} = I_{BAT} = 0\text{mA}$, $\overline{EN} = L$ ($V_{BAT} > V_{REGx}$) | -- | 1 | 2 | mA |
| | | $I_{SYS} = I_{BAT} = 0\text{mA}$, $\overline{EN} = H$ ($V_{BAT} > V_{REGx}$) | -- | 0.8 | 1.5 | mA |
| VIN Suspend Current | I_{USUS} | $V_{IN} = 5\text{V}$, $USUS = H$ | -- | 195 | 300 | μA |
| VBAT Sleep Leakage Current | I_{SLEEP} | $V_{BAT} > V_{IN}$ ($V_{IN} = 0\text{V}$) | -- | 5 | 15 | μA |
| VIN-BAT VOS Rising | V_{OS_H} | | -- | 200 | 300 | mV |
| VIN-BAT VOS Falling | V_{OS_L} | | 10 | 50 | -- | mV |

| Parameter | Symbol | Test Conditions | Min | Typ | Max | Unit |
|---|-----------------------|--|------|------|------|------|
| Voltage Regulation | | | | | | |
| System Regulation Voltage | V _{SYS} | I _{SYS} = 800mA | 4.3 | 4.4 | 4.5 | V |
| Battery Regulation Voltage | V _{REG1} | 0 to 85°C, Loading = 20mA When VSET = H | 4.16 | 4.2 | 4.23 | V |
| Battery Regulation Voltage | V _{REG2} | 0 to 85°C, Loading = 20mA When VSET = L | 4.01 | 4.05 | 4.08 | V |
| APPM Regulation Voltage | ΔV _{APPM} | V _{SYS} - ΔV _{APPM} | 120 | 200 | 280 | mV |
| DPM Regulation Voltage | V _{DPM} | I _{SETL} = L | 4.3 | 4.4 | 4.5 | V |
| VIN to V _{SYS} MOSFET Ron | R _{DS(ON)} | I _{VIN} = 1000mA | -- | 0.2 | 0.35 | Ω |
| BAT to V _{SYS} MOSFET Ron | R _{DS(ON)} | V _{BAT} = 4.2V, I _{SYS} = 1A | -- | 0.05 | 0.1 | Ω |
| Re-Charge Threshold | ΔV _{REGCHG} | Battery Regulation – Recharge level | 60 | 100 | 140 | mV |
| Current Regulation | | | | | | |
| ISETA Set Voltage (Fast Charge Phase) | V _{ISETA} | V _{BAT} = 4V, R _{ISETA} = 1kΩ | -- | 2 | -- | V |
| VIN Charge Setting Range | I _{CHG} | | 100 | -- | 1200 | mA |
| VIN Charge Current Accuracy1 | I _{CHG1} | V _{BAT} = 4V, R _{ISETA} = 1kΩ ISET = H | 570 | 600 | 630 | mA |
| VIN Charge Current Accuracy2 | I _{CHG2} | V _{BAT} = 3.8V, R _{ISETA} = 1kΩ ISET = L | 285 | 300 | 315 | mA |
| VIN Current Limit | I _{VIN} | I _{SETL} = L (1.5A Mode) | 1 | 1.5 | 1.8 | A |
| | | I _{SETL} = H, ISETU = H (500mA Mode) | 430 | 475 | 500 | mA |
| | | I _{SETL} = H, ISETU = L (100mA Mode) | 70 | 95 | 100 | mA |
| Pre-Charge | | | | | | |
| BAT Pre-Charge Threshold | V _{PRECH} | BAT Falling | 2.7 | 2.8 | 2.9 | V |
| BAT Pre-Charge Threshold Hysteresis | ΔV _{PRECH} | | -- | 200 | -- | mV |
| Pre-Charge Current | I _{CHG_PRE} | V _{BAT} = 2V | 5 | 10 | 15 | % |
| Charge Termination Detection | | | | | | |
| Termination Current Ratio to Fast Charge (Except USB100 Mode) | I _{TERM} | I _{SETL} = L, ISETU = H I _{SETL} = H, ISETU = X | 5 | 10 | 15 | % |
| Termination Current Ratio to Fast Charge (USB100 Mode) | I _{TERM2} | I _{SETL} = L, ISETU = L | -- | 3.3 | -- | % |
| Login Input/Output | | | | | | |
| CHG Pull Down Voltage | V _{CHG} | I _{CHG} = 5mA | -- | 200 | -- | mV |
| PGOOD Pull Down Voltage | V _{PGOOD} | I _{PGOOD} = 5mA | -- | 200 | -- | mV |
| TS_FAULT Pull Down Voltage | V _{TS_FAULT} | I _{TS_FAULT} = 5mA | -- | 200 | -- | mV |
| EN, ISETL, USUS, ISETU, VSET, ISET Threshold Voltage | Logic-High | V _{IH} | 1.5 | -- | -- | V |
| | Logic-Low | V _{IL} | -- | -- | 0.4 | |

| Parameter | Symbol | Test Conditions | Min | Typ | Max | Unit |
|---|----------------------|--|-------|-------|-------|---------|
| Protection | | | | | | |
| Thermal Regulation | T _{REG} | | -- | 125 | -- | °C |
| Thermal Shutdown Temperature | T _{SD} | | -- | 155 | -- | °C |
| Thermal Shutdown Hysteresis | ΔT _{SD} | | -- | 20 | -- | °C |
| Over Voltage Protection | V _{OVP} | V _{IN} Rising | 6.25 | 6.5 | 6.75 | V |
| Over Voltage Protection Hysteresis | ΔV _{OVP} | V _{IN} = 7V to 5V, V _{OVP} – ΔV _{OVP} | -- | 100 | -- | mV |
| Output Short Circuit Detection Threshold | V _{SHORT} | V _{BAT} – V _{SYS} | -- | 300 | -- | mV |
| Time | | | | | | |
| Pre-Charge Fault Time | t _{PCHG} | C _{TIMER} = 1μF (1/8 x t _{FCHG}) | 1440 | 1800 | 2160 | s |
| Fast Charge Fault Time | t _{FCHG} | C _{TIMER} = 1μF | 11520 | 14400 | 17280 | s |
| $\overline{\text{PGOOD}}$ Deglitch Time | t _{PGOOD} | Time measured from V _{IN} : 0→5V 1μs rise time to $\overline{\text{PGOOD}} = L$ | -- | 1 | -- | s |
| Input Over Voltage Blanking Time | t _{OVP} | | -- | 50 | -- | μs |
| Pre-Charge to Fast-Charge Deglitch Time | t _{PF} | | -- | 25 | -- | ms |
| Fast-Charge to Pre-Charge Deglitch Time | t _{FP} | | -- | 25 | -- | ms |
| Termination Deglitch Time | t _{TERMI} | | -- | 25 | -- | ms |
| Recharge Deglitch Time | t _{RECHG} | | -- | 100 | -- | ms |
| Input Power Loss to SYS LDO Turn-Off Delay Time | t _{NO_IN} | | -- | 25 | -- | ms |
| Short Circuit ,Deglitch Time | t _{SHORT} | | -- | 250 | -- | μs |
| Short Circuit Recovery Time | t _{SHORT-R} | | -- | 64 | -- | ms |
| Other | | | | | | |
| VP (External used only) | V _{VP} | | 2.95 | -- | 3.6 | V |
| VP Under Voltage Lockout Threshold | | Falling Threshold | -- | 0.8 | -- | V |
| TS Battery Detect Threshold | V _{TS} | | 2.75 | 2.85 | 2.95 | V |
| NTC | | | | | | |
| Low Temperature Trip Point | V _{COLD} | Rising Threshold | 73 | 74 | 75 | % of VP |
| Low Temperature Trip Point Hysteresis | ΔV _{COLD} | | -- | 1 | -- | % of VP |
| High Temperature Trip Point | V _{HOT} | Falling Threshold | 27 | 28 | 29 | % of VP |
| High Temperature Trip Point Hysteresis | ΔV _{HOT} | | -- | 1 | -- | % of VP |

Note 1. Stresses beyond those listed under “Absolute Maximum Ratings” June cause permanent damage to the device. These are stress ratings only, and functional operation of the device at these or any other conditions beyond those indicated in the operational sections of the specifications is not implied. Exposure to absolute maximum rating conditions June affect device reliability.

Note 2. Guaranteed by design.

Note 3. θ_{JA} is measured under natural convection (still air) at $T_A = 25^\circ\text{C}$ with the component mounted on a high effective-thermal-conductivity four-layer test board on a JEDEC 51-7 thermal measurement standard. θ_{JC} is measured at the exposed pad of the package.

Note 4. Devices are ESD sensitive. Handling precautions are recommended.

Note 5. The device is not guaranteed to function outside its operating conditions.

Typical Operating Characteristics

Charger On/Off Control from \overline{EN}

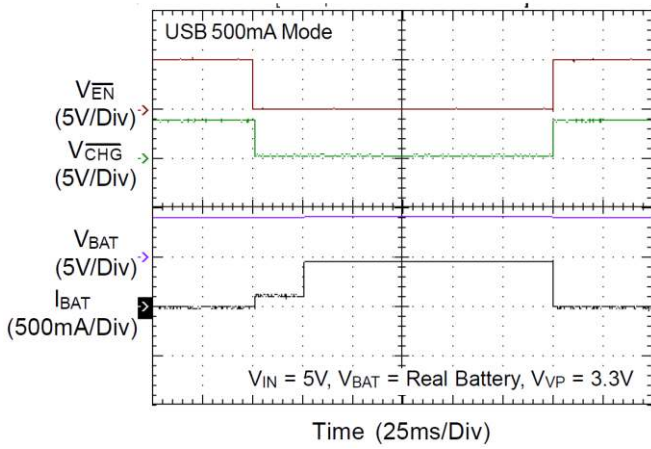

Charger On/Off Control from V_{IN}

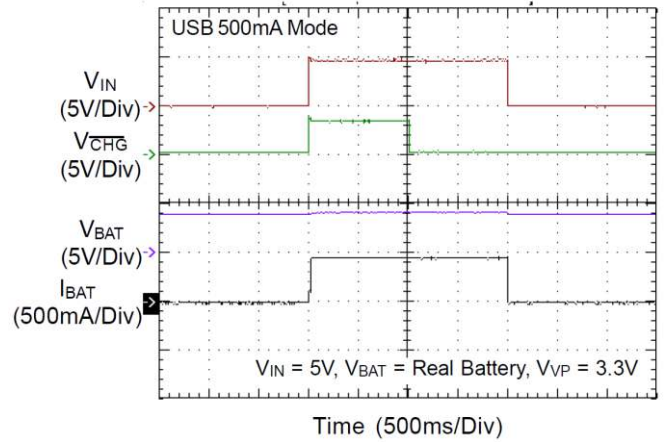

TS Inserted/Removed

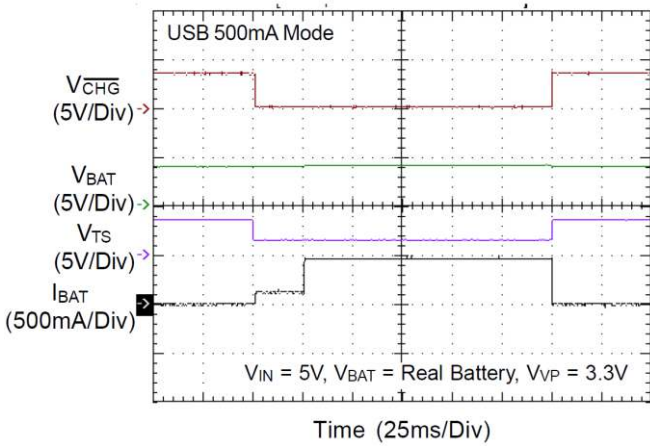

V_{IN} Removal

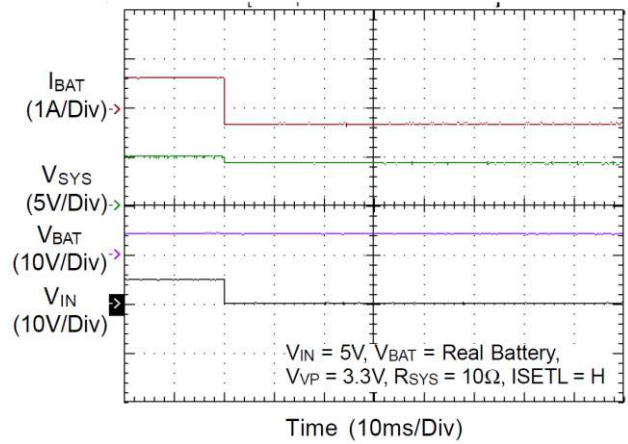

V_{IN} Hot-plug with NTC/without Battery

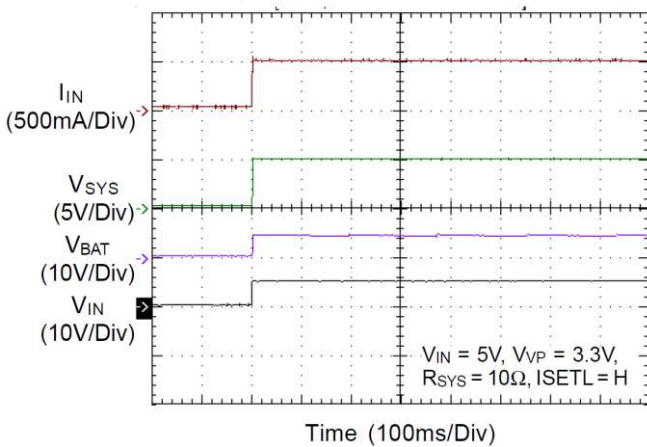

V_{IN} Hot-plug without NVC/Battery

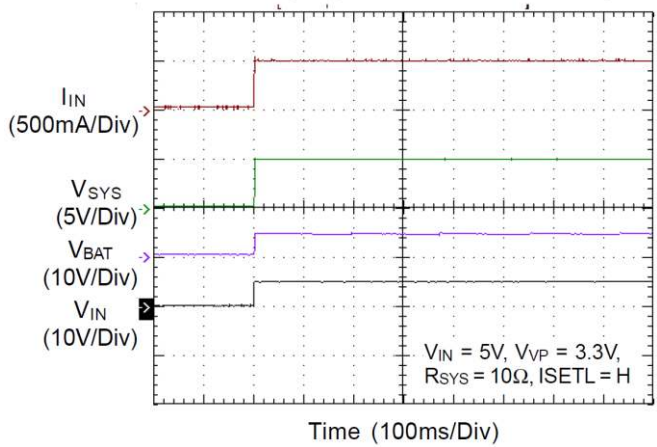

V_{IN} Hot-plug with Battery

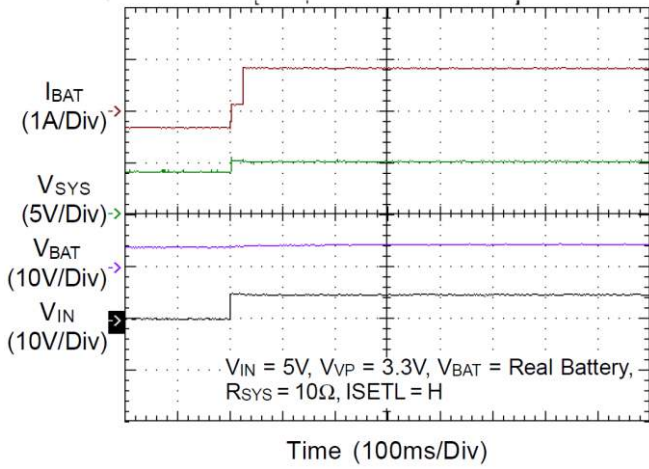

V_{IN} Over Voltage Protection

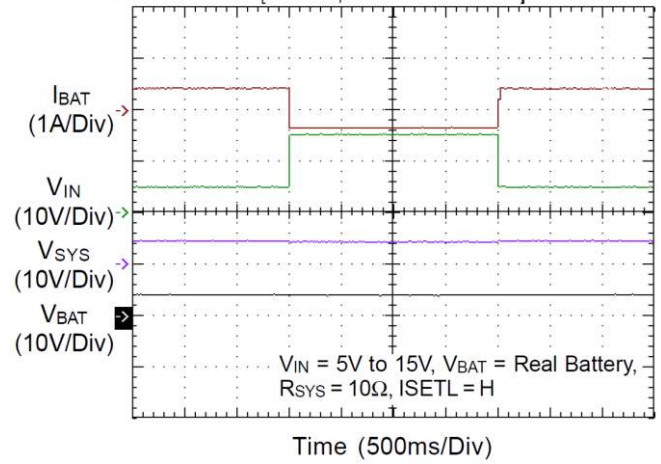

System Regulation Voltage vs. Temperature

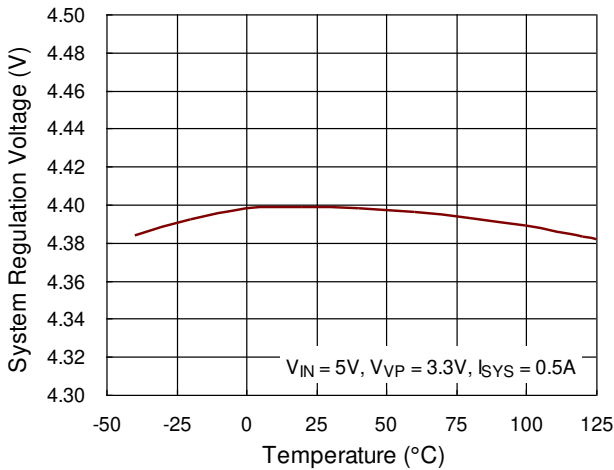

OVP Threshold Voltage vs. Temperature

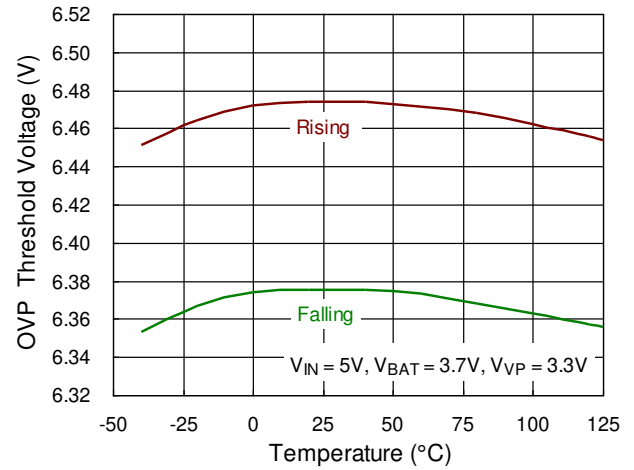

V_{IN} - V_{SYS} Dropout Voltage vs. Temperature

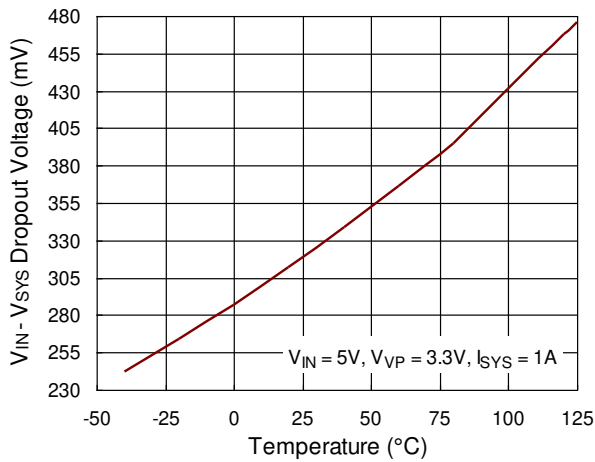

V_{BAT} - V_{SYS} Dropout Voltage vs. Temperature

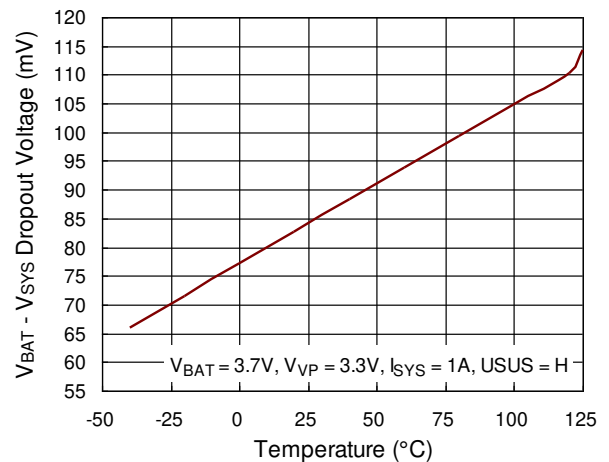

I_{CHG} Thermal Regulation vs. Temperature

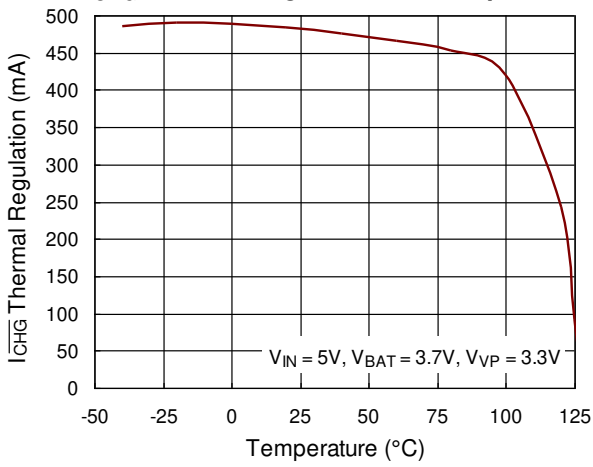

Battery Regulation Voltage vs. Temperature

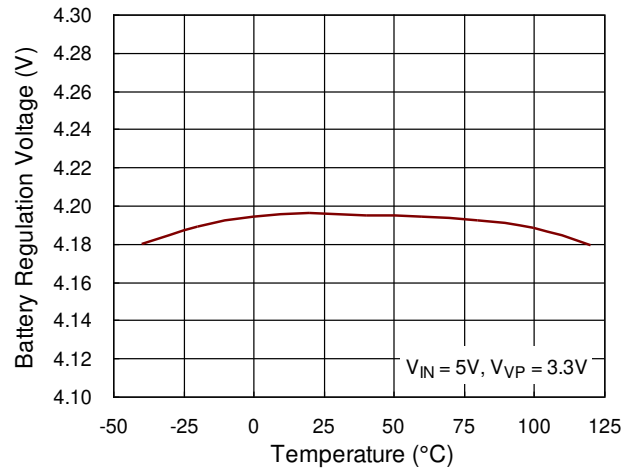

Precharge Current vs. Battery Voltage

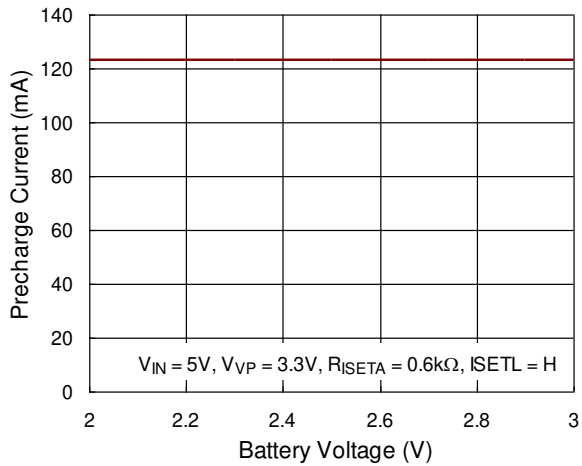

Fastcharge Current vs. Battery Voltage

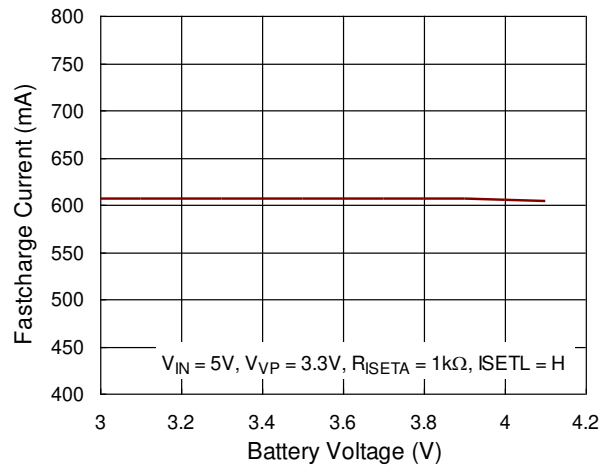

Application Information

Richtek's component specification does not include the following information in the Application Information section. Thereby no warranty is given regarding its validity and accuracy. Customers should take responsibility to verify their own designs and to ensure the functional suitability of their components and systems.

The RT9519B is a fully integrated single-cell Li-ion battery charger ideal for portable applications. The internal thermal feedback circuitry regulates the die temperature to optimize the charge rate for all ambient temperatures. Other features include under voltage protection and over voltage protection.

Pre-charge Mode

When the output voltage is lower than 2.8V, the charging current will be reduced to a fast-charge current ratio set by R_{ISETA} to protect the battery life time.

Fast-charge Mode

When the output voltage is higher than 3V, the charging current will be equal to the fast-charge current set by R_{ISETA}.

Constant-Voltage Mode

When the output voltage is near 4.2V, and the charging current fall below the termination current, after a deglitch time check of 25ms, the charger will become disabled and CHG will go from L to H.

Re-charge Mode

When the chip is in charge termination mode, the charging current will gradually go down to zero. However, once the voltage of the battery drops to below 4.1V, there will be a deglitch time of 100ms and then the charging current will resume again.

Charging Current Decision

The charge current can be set according to the following equations :

If ISET = H (for I_{CHG1})

$$I_{CHG_FAST} = \frac{V_{ISETA}}{R_{ISETA}} \times 300$$

If ISET = L (for I_{CHG2})

$$I_{CHG_FAST} = \frac{V_{ISETA}}{R_{ISETA}} \times 150$$

$$I_{CHG_PRE} = 10\% \times I_{CHG_FAST}$$

Time Fault

During the fast charge phase, several events may increase the charging time.

For example the system load current may have activated the APPM loop which reduces the available charging current, the device has entered thermal regulation because the IC junction temperature has exceeded T_{REG}. During each of these events, if 3V < V_{BAT} < 4.1V, the internal charging time is slowed down proportionately to the reduction in charging current. However, once the duration exceeds the fault time, the CHG output will flash at approximately 2Hz to indicate a fault condition and the charge current will be reduced to about 1mA.

$$t_{FCHG_true} = t_{FCHG} \times \frac{2V}{V_{ISETA}}$$

t_{FCHG_true} : modified timer in fast

t_{FCHG} : original timer in fast charger

$$t_{FCHG} = 14400 \times \left(\frac{C_{TIMER}}{1\mu F} \right)$$

$$t_{PCHG} = \frac{t_{FCHG}}{8}$$

t_{PCHG} : timer in pre-charge

Time fault release methods :

- (1) Re-plug power
- (2) Toggle \overline{EN}
- (3) Enter/exit suspend mode
- (4) Remove Battery
- (5) OVP

Note that the fast charge fault time is independent of the charge current.

Power Good

VIN Power Good ($\overline{PGOOD} = L$)

| Input State | \overline{PGOOD} Output |
|---|---------------------------|
| $V_{IN} < V_{UVLO}$ | High Impedance |
| $V_{UVLO} < V_{IN} < V_{BAT} + V_{OS_H}$ | High Impedance |
| $V_{BAT} + V_{OS_H} < V_{IN} < V_{OVP}$ | Low Impedance |
| $V_{IN} > V_{OVP}$ | High Impedance |

Charge State Indicator

| Charge State | \overline{CHG} Output |
|-------------------------------------|---------------------------------|
| Charging | Low (for first charge cycle) |
| Charging Suspended by Thermal Loop | |
| Safety Timers Expired | 2Hz Flash |
| Charging Done | High Impedance |
| Recharging after Termination | |
| IC Disabled or no Valid Input Power | |

Battery Pack Temperature Monitoring

The battery pack temperature monitoring function can be realized by connecting the TS pin to an external Negative Temperature Coefficient (NTC) thermistor to prevent over temperature condition. Charging is suspended when the voltage at the TS pin is out of normal operating range. The internal timer is then paused, but the value is maintained. When the TS pin voltage returns back to normal operating range, charging will resume and the safe charge timer will continue to count down from the point where it was suspended. Note that although charging is suspended due to the battery pack temperature fault, the CHG pin will continue to remain low and indicate charging.

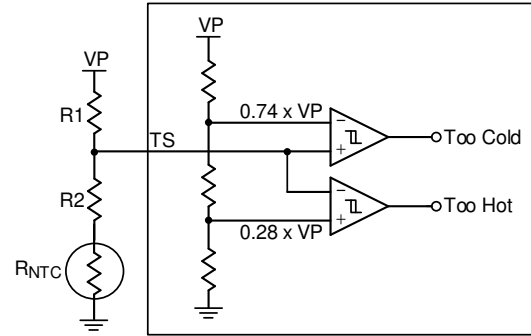

Figure 1

Too Cold Temperature

$$R_{COLD} = R_{NTC}$$

Too Hot Temperature

$$R_{HOT} = R_{NTC}$$

$$\frac{R_2 + R_{COLD}}{R_{COLD} + R_1 + R_2} = 0.74 \quad (1)$$

$$\frac{R_2 + R_{HOT}}{R_{HOT} + R_1 + R_2} = 0.28 \quad (2)$$

From (1), (2)

$$R_1 = \frac{R_{COLD} - R_{HOT}}{2.457}$$

$$R_2 = 0.359 \times R_1 - R_{HOT}$$

If $R_2 < 0$

$$\frac{R_{COLD}}{R_{COLD} + R_1} = 0.74 \quad (3)$$

From (3)

$$R_1 = \frac{R_{COLD}}{0.74} - R_{COLD}$$

Charge Enable

When \overline{EN} is High, the charger turns on. When \overline{EN} is low, the charger turns off. \overline{EN} is pulled low at the initial condition.

VIN Input Current Limit

| \overline{ISETL} | ISETU | VIN Input Current Limit |
|--------------------|-------|-------------------------|
| L | L | 95mA |
| L | H | 475mA |
| H | X | 1.5A |

Suspend Mode

Set USUS = H, and the charge will enter Suspend Mode. In the Suspend Mode, $\overline{\text{CHG}}$ is in high impedance and $\text{IUSUS}(\text{MAX}) < 300\mu\text{A}$.

Power Switch

For the RT9519B, there are three power scenarios :

- (1) When a battery and an external power supply (USB or adapter) are connected simultaneously :

If the system load requirements exceed that of the input current limit, the battery will be used to supplement the current to the load. However, if the system load requirements are less than that of the input current limit, the excess power from the external power supply will be used to charge the battery.

- (2) When only the battery is connected to the system :
The battery provides the power to the system.

- (3) When only an external power supply is connected to the system :
The external power supply provides the power to the system.

Input DPM Mode

For the RT9519B, the input voltage is monitored when the USB100 or USB500 is selected. If the input voltage is lower than V_{DPM} , the input current limit will be reduced to stop the input voltage from dropping any further. This can prevent the IC from damaging improperly configured or inadequately designed USB sources.

APPM Mode

Once the sum of the charging and system load currents becomes higher than the maximum input current limit, the SYS pin voltage will be reduced. When the SYS pin voltage is reduced to V_{APPM} , the RT9519B will automatically operate in APPM mode. In this mode, the charging current is reduced while the SYS current is

increased to maintain system output. In APPM mode, the battery termination function is disabled.

Battery Supplement Mode Short Circuit Protect

In APPM mode, the SYS voltage will continue to drop if the charge current is zero and the system load increases beyond the input current limit. When the SYS voltage decreases below the battery voltage, the battery will kick in to supplement the system load until the SYS voltage rises above the battery voltage.

While in supplement mode, there is no battery supplement current regulation. However, a built in short circuit protection feature is available to prevent any abnormal current situations. While the battery is supplementing the load, if the difference between the battery and SYS voltage becomes more than the short circuit threshold voltage, SYS will be disabled. After a short circuit recovery time, $t_{\text{SHORT_R}}$, the counter will be restarted. In supplement mode, the battery termination function is disabled. Note that for the battery supply mode exit condition, $V_{\text{BAT}} - V_{\text{SYS}} < 0\text{V}$.

Thermal Regulation and Thermal Shutdown

The RT9519B provides a thermal regulation loop function to monitor the device temperature. If the die temperature rises above the regulation temperature, T_{REG} , the charge current will automatically be reduced to lower the die temperature. However, in certain circumstances (such as high V_{IN} , heavy system load, etc.) even with the thermal loop in place, the die temperature may still continue to increase. In this case, if the temperature rises above the thermal shutdown threshold, T_{SD} , the internal switch between V_{IN} and SYS will be turned off. The switch between the battery and SYS will remain on, however, to allow continuous battery power to the load. Once the die temperature decreases by ΔT_{SD} , the internal switch between V_{IN} and SYS will be turned on again and the device returns to normal thermal regulation.

Charging Profile

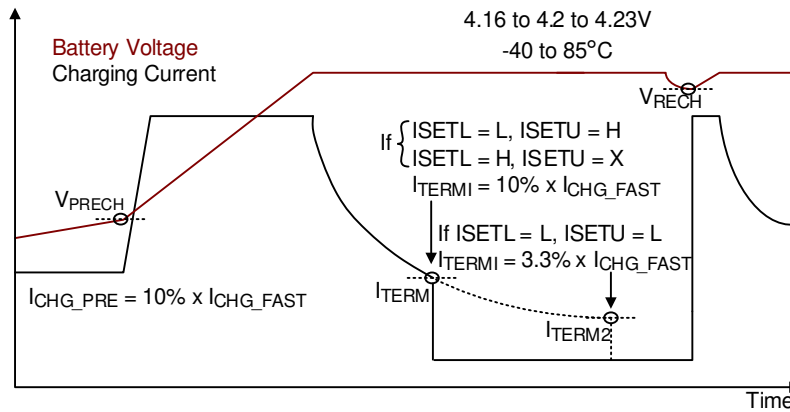

APPM Profile

1.5A Mode :

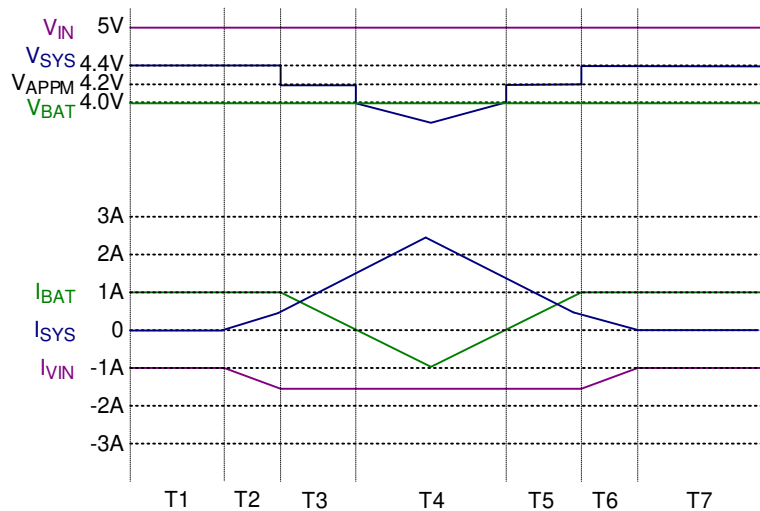

| | I_{SYS} | V_{SYS} | I_{VIN} | I_{BAT} |
|--------|---|---------------------------------------|----------------------|-------------------------|
| T1, T7 | 0 | SYS Regulation Voltage | CHG_MAX | CHG_MAX |
| T2, T6 | $< I_{VIN_OC} - CHG_MAX$ | SYS Regulation Voltage | $I_{SYS} + CHG_MAX$ | CHG_MAX |
| T3, T5 | $> I_{VIN_OC} - CHG_MAX$ $< I_{VIN_OC}$ | Auto Charge Voltage Threshold | V_{IN_OC} | $V_{IN_OC} - I_{SYS}$ |
| T4 | $> I_{VIN_OC}$ | $V_{BAT} - I_{BAT} \times R_{DS(ON)}$ | V_{IN_OC} | $I_{SYS} - I_{VIN_OC}$ |

USB 500mA Mode :

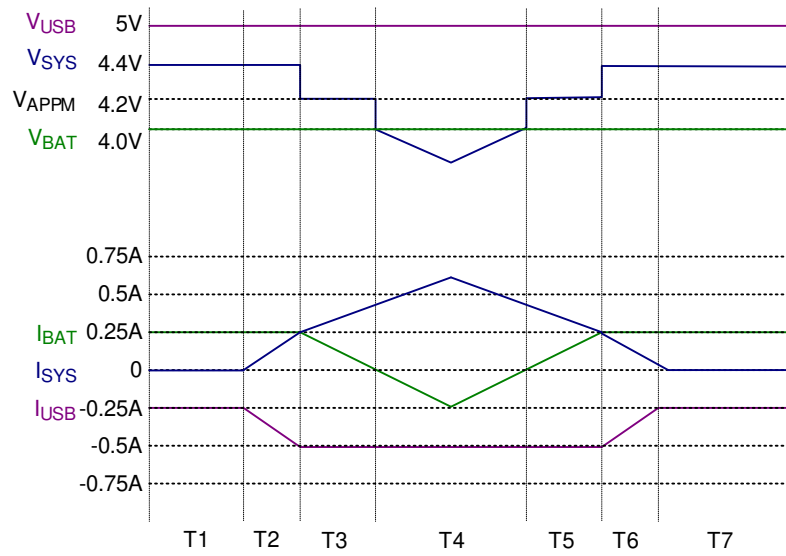

| | I_{sys} | V_{sys} | I_{usb} | I_{BAT} |
|--------|---|---------------------------------------|------------------------|-------------------------------|
| T1, T7 | 0 | SYS Regulation Voltage | CHG_MAX | CHG_MAX |
| T2, T6 | $< I_{VIN_OC} (USB) - CHG_MAX$ | SYS Regulation Voltage | $I_{SYS} + CHG_MAX$ | CHG_MAX |
| T3, T5 | $> I_{VIN_OC} (USB) - CHG_MAX$ $< I_{VIN_OC} (USB)$ | Auto Charge Voltage Threshold | $I_{VIN_OC} (USB)$ | $I_{VIN_OC} (USB) - I_{SYS}$ |
| T4 | $> I_{VIN_OC} (USB)$ | $V_{BAT} - I_{BAT} \times R_{DS(ON)}$ | $I_{VIN_OC} (USB)$ | $I_{SYS} - I_{VIN_OC} (USB)$ |

VSET vs. VREG, ISET vs. ICHG

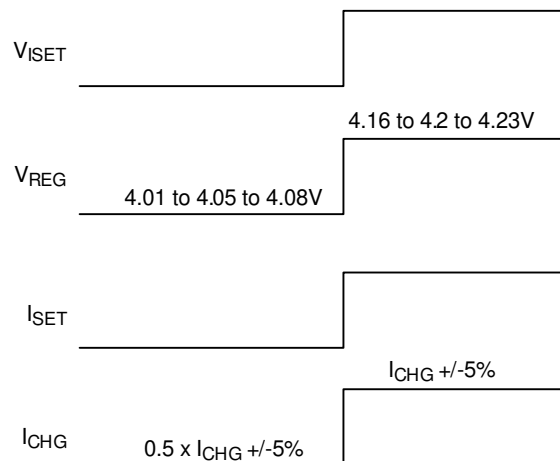

For JEITA Battery Temperature Standard :
 CV regulation voltage will change at the following battery Temp ranges
 0°C to 10°C and 45°C to 60°C
 CC regulation current will change at the following battery Temp ranges
 0°C to 10°C and 45°C to 60°C

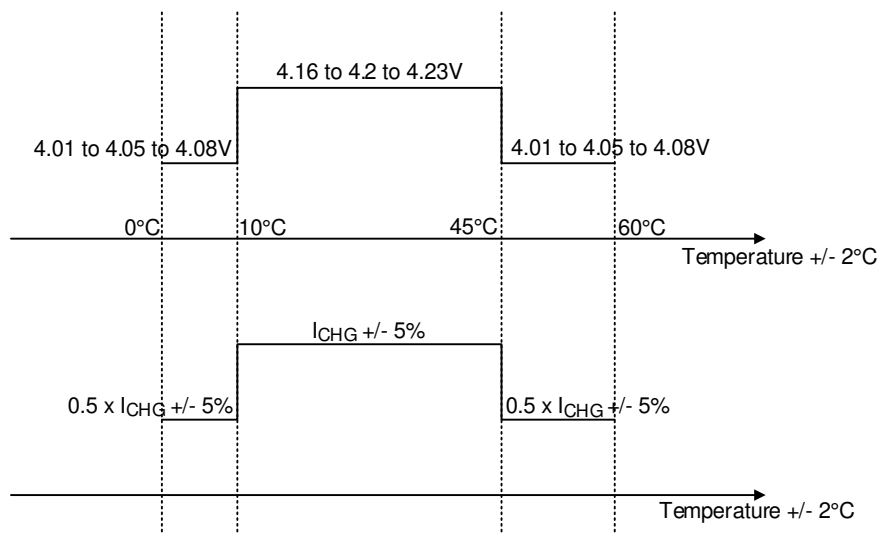

RT9519B Operation State Diagram for Charging

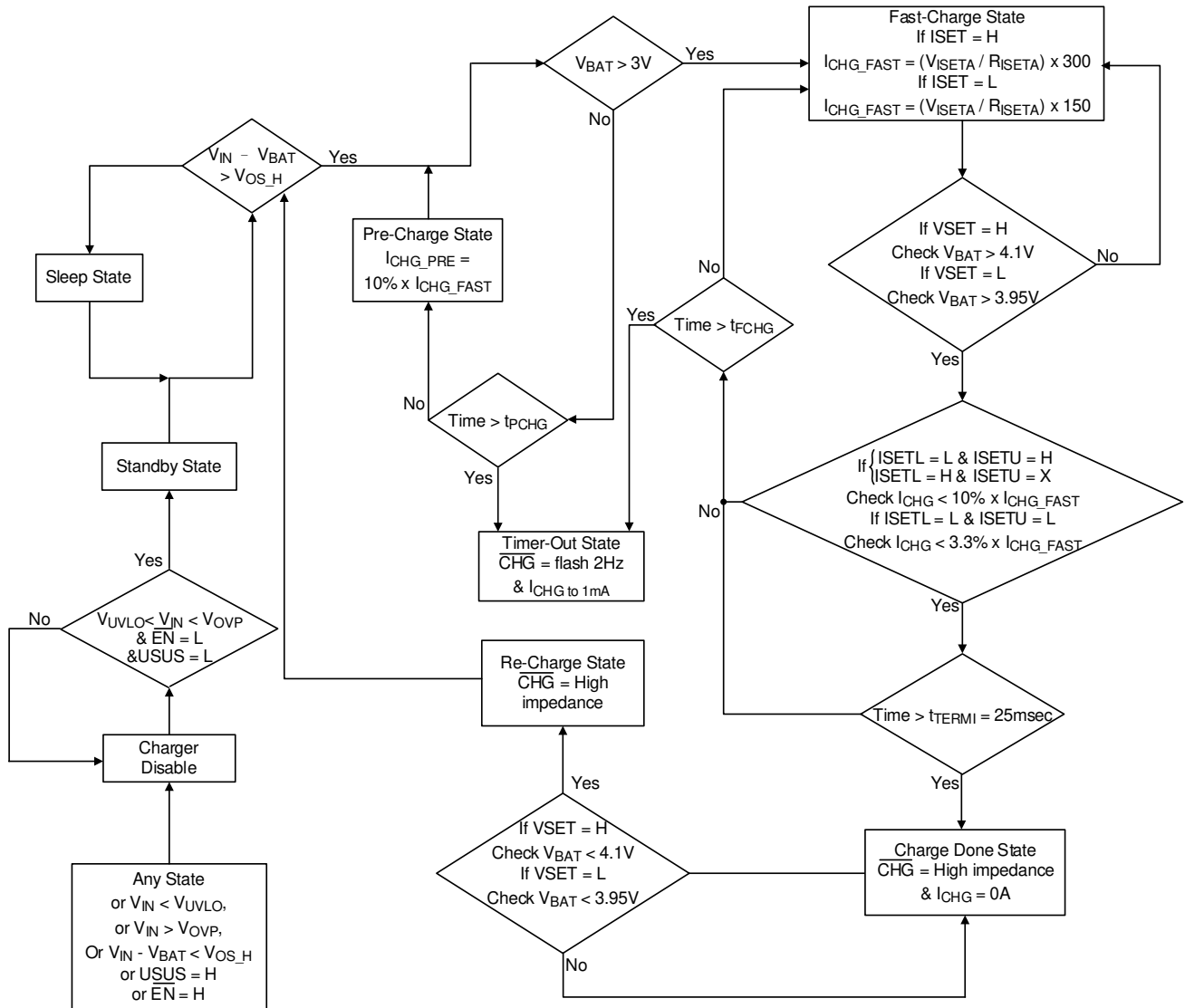

Operation State Diagram for TS PIN

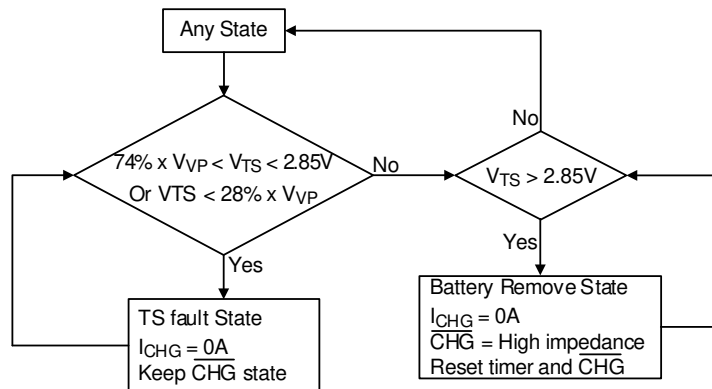

Thermal Considerations

The junction temperature should never exceed the absolute maximum junction temperature $T_{J(MAX)}$, listed under Absolute Maximum Ratings, to avoid permanent damage to the device. The maximum allowable power dissipation depends on the thermal resistance of the IC package, the PCB layout, the rate of surrounding airflow, and the difference between the junction and ambient temperatures. The maximum power dissipation can be calculated using the following formula :

$$P_{D(MAX)} = (T_{J(MAX)} - T_A) / \theta_{JA}$$

where $T_{J(MAX)}$ is the maximum junction temperature, T_A is the ambient temperature, and θ_{JA} is the junction-to-ambient thermal resistance.

For continuous operation, the maximum operating junction temperature indicated under Recommended Operating Conditions is 125°C. The junction-to-ambient thermal resistance, θ_{JA} , is highly package dependent. For a WQFN-20L 3x3 package, the thermal resistance, θ_{JA} , is 68°C/W on a standard JEDEC 51-7 high effective-thermal-conductivity four-layer test board. The maximum power dissipation at $T_A = 25^\circ\text{C}$ can be calculated as below :

$$P_{D(MAX)} = (125^\circ\text{C} - 25^\circ\text{C}) / (68^\circ\text{C}/\text{W}) = 1.471\text{W for a WQFN-20L 3x3 package.}$$

The maximum power dissipation depends on the operating ambient temperature for the fixed $T_{J(MAX)}$ and the thermal resistance, θ_{JA} . The derating curves in Figure 2 allows the designer to see the effect of rising ambient temperature on the maximum power dissipation.

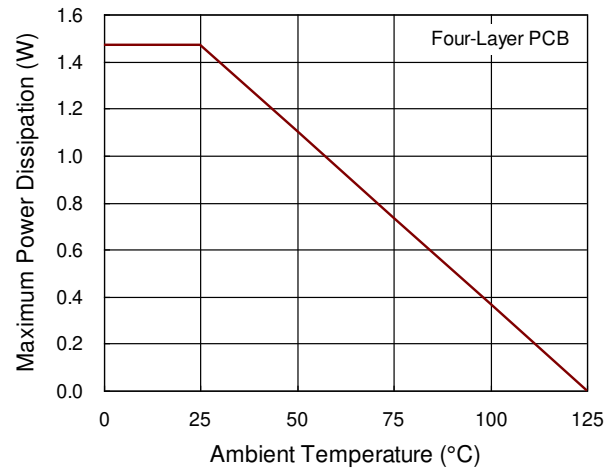

Figure 2. Derating Curves for RT9519B Package

Layout Considerations

The RT9519B is a fully integrated low cost single cell Li-ion battery charger ideal for portable applications. Careful PCB layout is necessary. For best performance, place all peripheral components as close to the IC as possible.

A short connection is highly recommended. The following guidelines should be strictly followed when designing a

PCB layout for the RT9519B.

- ▶ Input and output capacitor should be placed close to the IC and connected to ground plane. The input trace on the PCB should be placed far away from sensitive devices and shielded by the ground.
- ▶ The GND and exposed pad should be connected to a strong ground plane for heat sinking and noise protection.
- ▶ The connection of RISETA should be isolated from other noisy traces. A short wire is recommended to prevent EMI and noise coupling.

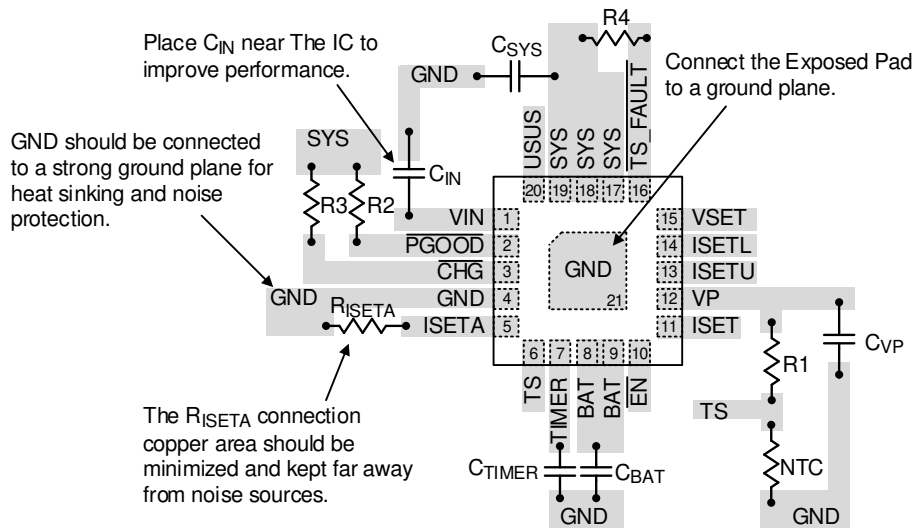
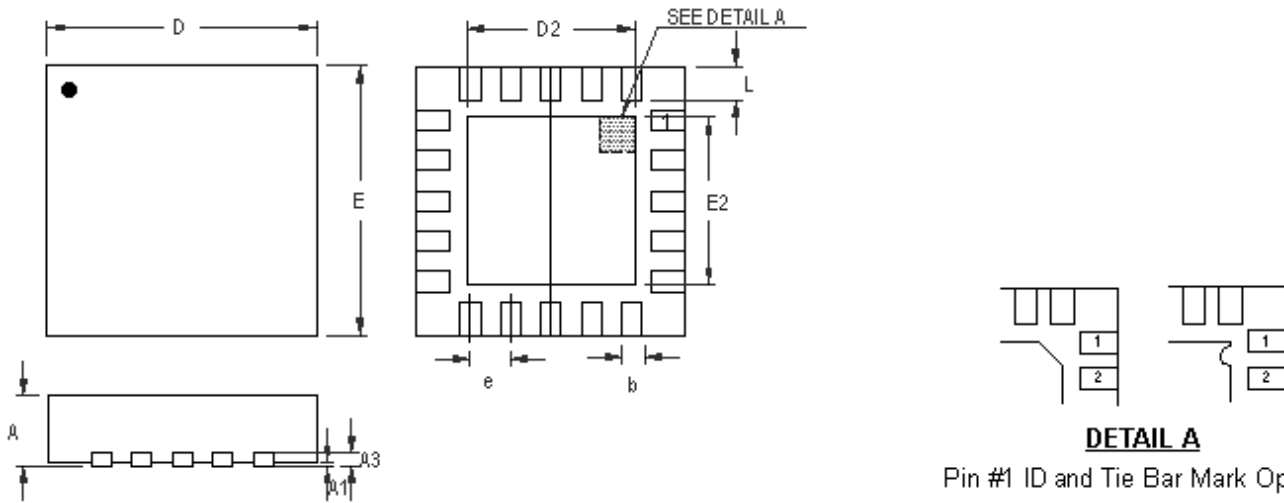

Figure 3. PCB Layout Guide

Outline Dimension



DETAIL A
Pin #1 ID and Tie Bar Mark Options

Note : The configuration of the Pin #1 identifier is optional, but must be located within the zone indicated.

| Symbol | Dimensions In Millimeters | | Dimensions In Inches | |
|--------|---------------------------|-------|----------------------|-------|
| | Min | Max | Min | Max |
| A | 0.700 | 0.800 | 0.028 | 0.031 |
| A1 | 0.000 | 0.050 | 0.000 | 0.002 |
| A3 | 0.175 | 0.250 | 0.007 | 0.010 |
| b | 0.150 | 0.250 | 0.006 | 0.010 |
| D | 2.900 | 3.100 | 0.114 | 0.122 |
| D2 | 1.650 | 1.750 | 0.065 | 0.069 |
| E | 2.900 | 3.100 | 0.114 | 0.122 |
| E2 | 1.650 | 1.750 | 0.065 | 0.069 |
| e | 0.400 | | 0.016 | |
| L | 0.350 | 0.450 | 0.014 | 0.018 |

W-Type 20L QFN 3x3 Package

Footprint Information

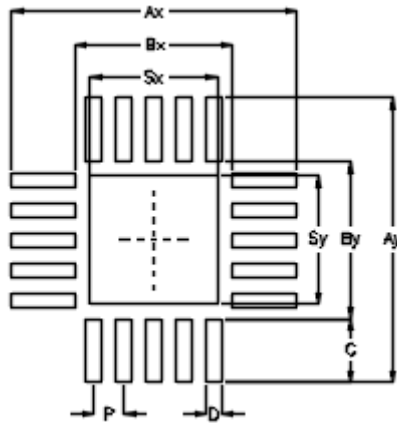

| Package | Number of Pin | Footprint Dimension (mm) | | | | | | | | | Tolerance |
|------------------|---------------|--------------------------|------|------|------|------|------|------|------|------|-----------|
| | | P | Ax | Ay | Bx | By | C | D | Sx | Sy | |
| V/W/U/XQFN3*3-20 | 20 | 0.40 | 3.80 | 3.80 | 2.10 | 2.10 | 0.85 | 0.20 | 1.70 | 1.70 | ±0.05 |

Packing Information

Tape and Reel Data

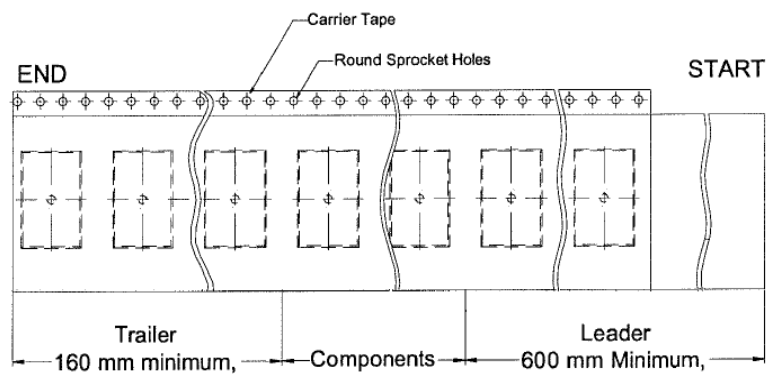
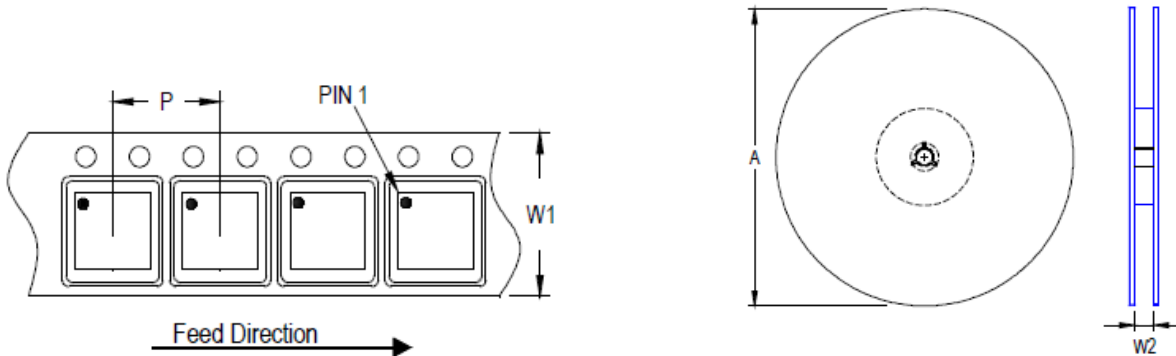



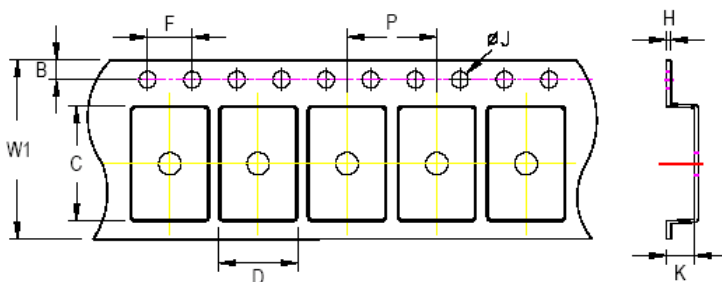



| Package Type | Tape Size (W1) (mm) | Pocket Pitch (P) (mm) | Reel Size (A) | | Units per Reel | Trailer (mm) | Leader (mm) | Reel Width (W2) Min./Max. (mm) |
|--------------|---------------------|-----------------------|---------------|------|----------------|--------------|-------------|--------------------------------|
| | | | (mm) | (in) | | | | |
| QFN/DFN 3x3 | 12 | 8 | 180 | 7 | 1,500 | 160 | 600 | 12.4/14.4 |



C, D and K are determined by component size.
The clearance between the components and the cavity is as follows:
- For 12mm carrier tape: 0.5mm max.

| Tape Size | W1 | | P | | B | | F | | ØJ | | H |
|-----------|--------|-------|-------|--------|--------|-------|-------|-------|-------|-------|---|
| | Max. | Min. | Max. | Min. | Max. | Min. | Max. | Min. | Max. | Max. | |
| 12mm | 12.3mm | 7.9mm | 8.1mm | 1.65mm | 1.85mm | 3.9mm | 4.1mm | 1.5mm | 1.6mm | 0.6mm | |

Tape and Reel Packing

| Step | Photo/Description | Step | Photo/Description |
|------|---|------|--|
| 1 |  <p>Reel 7"</p> | 4 |  <p>3 reels per inner box Box A</p> |
| 2 |  <p>HIC & Desiccant (1 Unit) inside</p> | 5 |  <p>12 inner boxes per outer box</p> |
| 3 |  <p>Caution label is on backside of Al bag</p> | 6 |  <p>Outer box Carton A</p> |

| Package | Reel | | Box | | | | Carton | | | |
|---------------|------|-------|-------|---------------|-------|-------|----------|----------------|-------|--------|
| | Size | Units | Item | Size(cm) | Reels | Units | Item | Size(cm) | Boxes | Unit |
| QFN & DFN 3x3 | 7" | 1,500 | Box A | 18.3*18.3*8.0 | 3 | 4,500 | Carton A | 38.3*27.2*38.3 | 12 | 54,000 |
| | | | Box E | 18.6*18.6*3.5 | 1 | 1,500 | | | | |

Packing Material Anti-ESD Property

| Surface Resistance | Aluminum Bag | Reel | Cover tape | Carrier tape | Tube | Protection Band |
|----------------------|---------------------|---------------------|---------------------|---------------------|---------------------|---------------------|
| Ω/cm^2 | $10^4 \sim 10^{11}$ | $10^4 \sim 10^{11}$ | $10^4 \sim 10^{11}$ | $10^4 \sim 10^{11}$ | $10^4 \sim 10^{11}$ | $10^4 \sim 10^{11}$ |

Richtek Technology Corporation

14F, No. 8, Tai Yuen 1st Street, Chupei City
 Hsinchu, Taiwan, R.O.C.
 Tel: (8863)5526789

Richtek products are sold by description only. Richtek reserves the right to change the circuitry and/or specifications without notice at any time. Customers should obtain the latest relevant information and data sheets before placing orders and should verify that such information is current and complete. Richtek cannot assume responsibility for use of any circuitry other than circuitry entirely embodied in a Richtek product. Information furnished by Richtek is believed to be accurate and reliable. However, no responsibility is assumed by Richtek or its subsidiaries for its use; nor for any infringements of patents or other rights of third parties which result from its use. No license is granted by implication or otherwise under any patent or patent rights of Richtek or its subsidiaries.

Datasheet Revision History

| Version | Date | Description | Item |
|----------------|-------------|--------------------|--|
| 02 | 2022/11/23 | Modify | Electrical Characteristics on P5 Application Information on P11 Footprint Information on P21 Packing Information on P22, 23, 24 |