

Introducing the LCD Explorer Demonstration Board

Overview

The LCD Explorer Demonstration Board is the latest 8-Common LCD Board for evaluation of the PIC24F and PIC18F LCD devices. The board comes with a PIC24FJ128GA310 PIM and has a PICTail™ Plus connector to showcase the PICTail™ Plus with the LCD microcontroller. Future devices with the 8-Common and 1/3 biasing will be supported on this demonstration board.

Features

- Eight Common LCD glass
- Supports 1/3 biasing with:
 - External resistor ladder
 - Internal resistor ladder
 - Charge pump biasing with capacitor
- Supports software as well as hardware contrast control
- Hardware RTCC support
- VBAT operation during VDD loss, RTCC can run on VBAT without VDD
- Analog pot to display the A/D capability
- Temperature sensor to display temperature using A/D
- PICTail Plus expansion connector for easy system evaluation with the PICTail Plus daughter cards⁽¹⁾
- CTMU switch to showcase touch sensing
- Four switches implemented for software demonstration
- Three ways to power the board:
 - Using the 9V power supply
 - Through a USB connector
 - Using two AAA batteries (not recommended for PICTail Plus)
- Connector for VBAT current measurement

Note 1: Only the upper slot can be used for the PICTail Plus.

Demonstration Software Operation

1. **Scrolling Banner:** In this mode, the LCD will scroll text, displaying the features of the device on the board. Pressing Switches, S3 or S4, will increase or decrease the speed of the scroll and Switch S1 or S2 will take the code to the voltmeter.
2. **Voltmeter:** This mode uses the A/D module to measure the voltage of the R20 pot through the analog channel. A voltage between 0.00V and VDD is displayed on the LCD using the LCD module. The voltage is continually updated until the mode is exited by pressing either S1 or S2 (which will go to Mode 4 or Mode 2).
3. **Thermometer:** This mode uses the A/D module to measure the temperature using TC1047AVNBTR, and converts to temperature, both in Celsius and Fahrenheit. The temperature is displayed on the LCD using the LCD module. Temperature is continually updated until the mode is exited by pressing either S1 or S2.
4. **Clock:** In this mode, the hardware RTCC runs and displays the time on the LCD screen until the mode is exited by pressing either S1 or S2.
5. **Software Contrast:** This mode will showcase the software contrast control and will display the variation by changing the bias levels through software. The mode is exited by pressing either the S1 or S2 switch. The software, documentation, firmware and other material for this demo can be downloaded from: <http://www.microchip.com/LCDEXplorer>

Americas

Atlanta - 678-957-9614
Boston - 774-760-0087
Chicago - 630-285-0071
Cleveland - 216-447-0464
Dallas - 972-818-7423
Detroit - 248-538-2250
Indianapolis - 317-773-8323
Los Angeles - 949-462-9523
Phoenix - 480-792-7200
Santa Clara - 408-961-6445
Toronto - 905-673-0699

Asia/Pacific

Australia - Sydney - 61-2-9868-6733
China - Beijing - 86-10-8569-7000
China - Chengdu - 86-28-8665-5511
China - Chongqing - 86-23-8980-9500
China - Hangzhou - 86-571-2819-3187
China - Hong Kong SAR - 852-2401-1200
China - Nanjing - 86-25-8473-2460
China - Qingdao - 86-532-8502-7355
China - Shanghai - 86-21-5407-5533
China - Shenyang - 86-24-2334-2829
China - Shenzhen - 86-755-8203-2660
China - Wuhan - 86-27-5980-5300
China - Xian - 86-29-8833-7252
China - Xiamen - 86-592-2388138
China - Zhuhai - 86-756-3210040
India - Bangalore - 91-80-3090-4444
India - New Delhi - 91-11-4160-8631
India - Pune - 91-20-2566-1512
Japan - Osaka - Tel: 81-66-152-7160
Japan - Yokohama - 81-45-471-6166
Korea - Daegu - 82-53-744-4301
Korea - Seoul - 82-2-554-7200
Malaysia - Kuala Lumpur - 60-3-6201-9857
Malaysia - Penang - 60-4-227-8870
Philippines - Manila - 63-2-634-9065
Singapore - 65-6334-8870
Taiwan - Hsin Chu - 886-3-5778-366
Taiwan - Kaohsiung - 886-7-213-7830
Taiwan - Taipei - 886-2-2500-6610
Thailand - Bangkok - 66-2-694-1351

Europe

Austria - Weis - 43-7242-2244-39
Denmark - Copenhagen - 45-4450-2828
France - Paris - 33-1-69-53-63-20
Germany - Munich - 49-89-627-144-0
Italy - Milan - 39-0331-742611
Netherlands - Drunen - 31-416-690399
Spain - Madrid - 34-91-708-08-90
UK - Wokingham - 44-118-921-5869

11/29/11



Microchip Technology Inc. • 2355 West Chandler Blvd. • Chandler, AZ 85224-6199

www.microchip.com

The Microchip name and logo, the Microchip logo and MPLAB are registered trademarks of Microchip Technology Incorporated in the U.S.A. and other countries. PICTail and PICkit are trademarks of Microchip Technology Incorporated in the U.S.A. and other countries. All other trademarks mentioned herein are property of their respective companies. © 2011, Microchip Technology Incorporated, Printed in the U.S.A. All Rights Reserved. 12/11

DS52026A

Introducing the LCD Explorer Demonstration Board

LCD Explorer Development Board Schematic

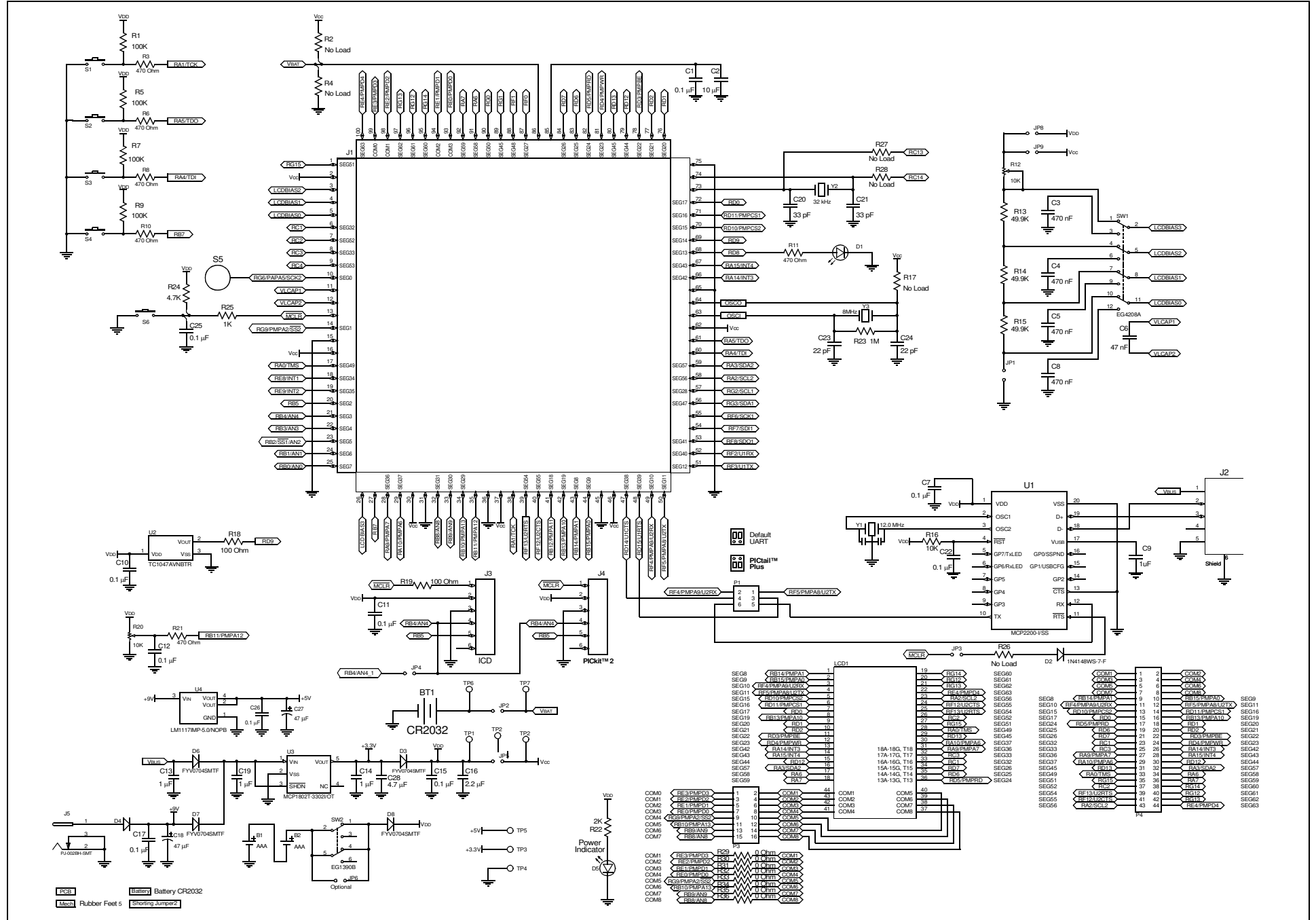

Introducing the LCD Explorer Demonstration Board

LCD Explorer Development Board Schematic (Continued)

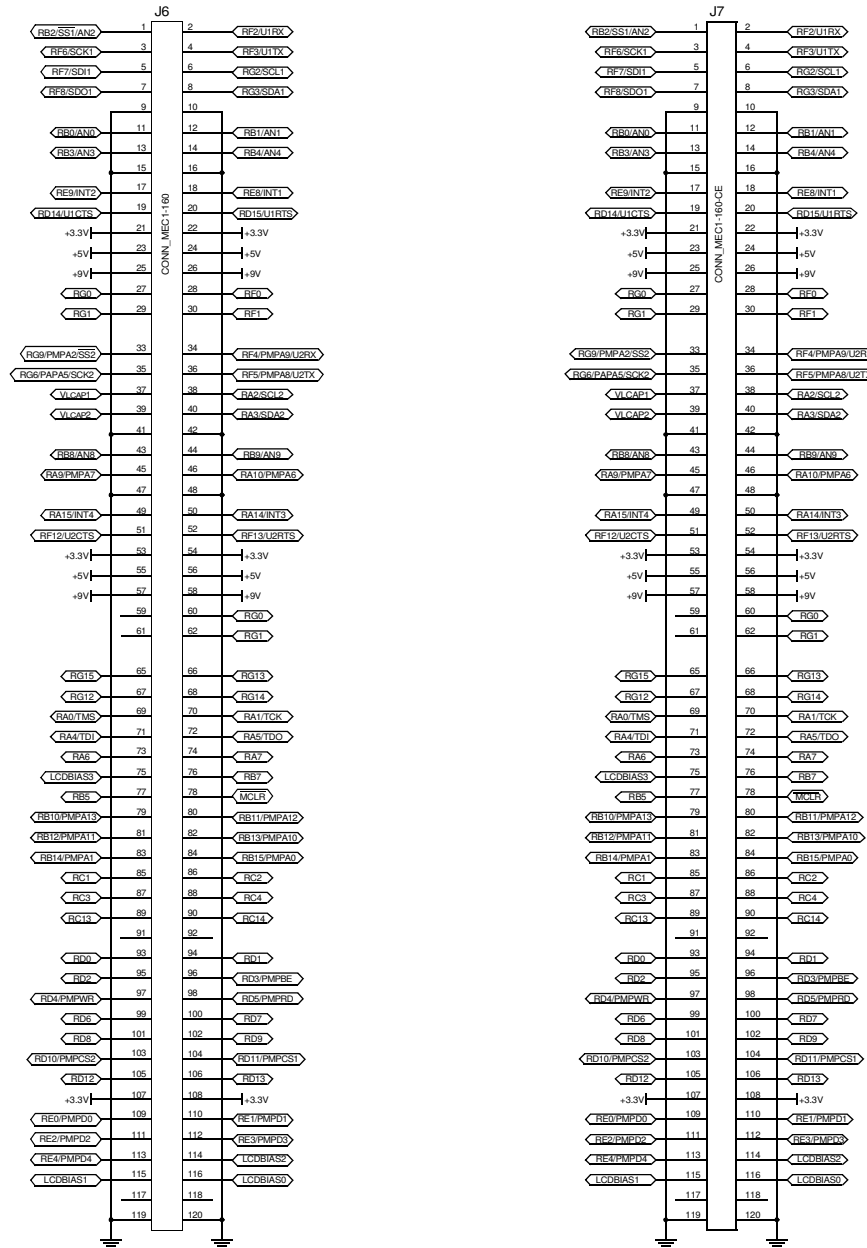

Introducing the LCD Explorer Demonstration Board

PIM for the PIC24FJ128GA310 LCD Plug-in Module

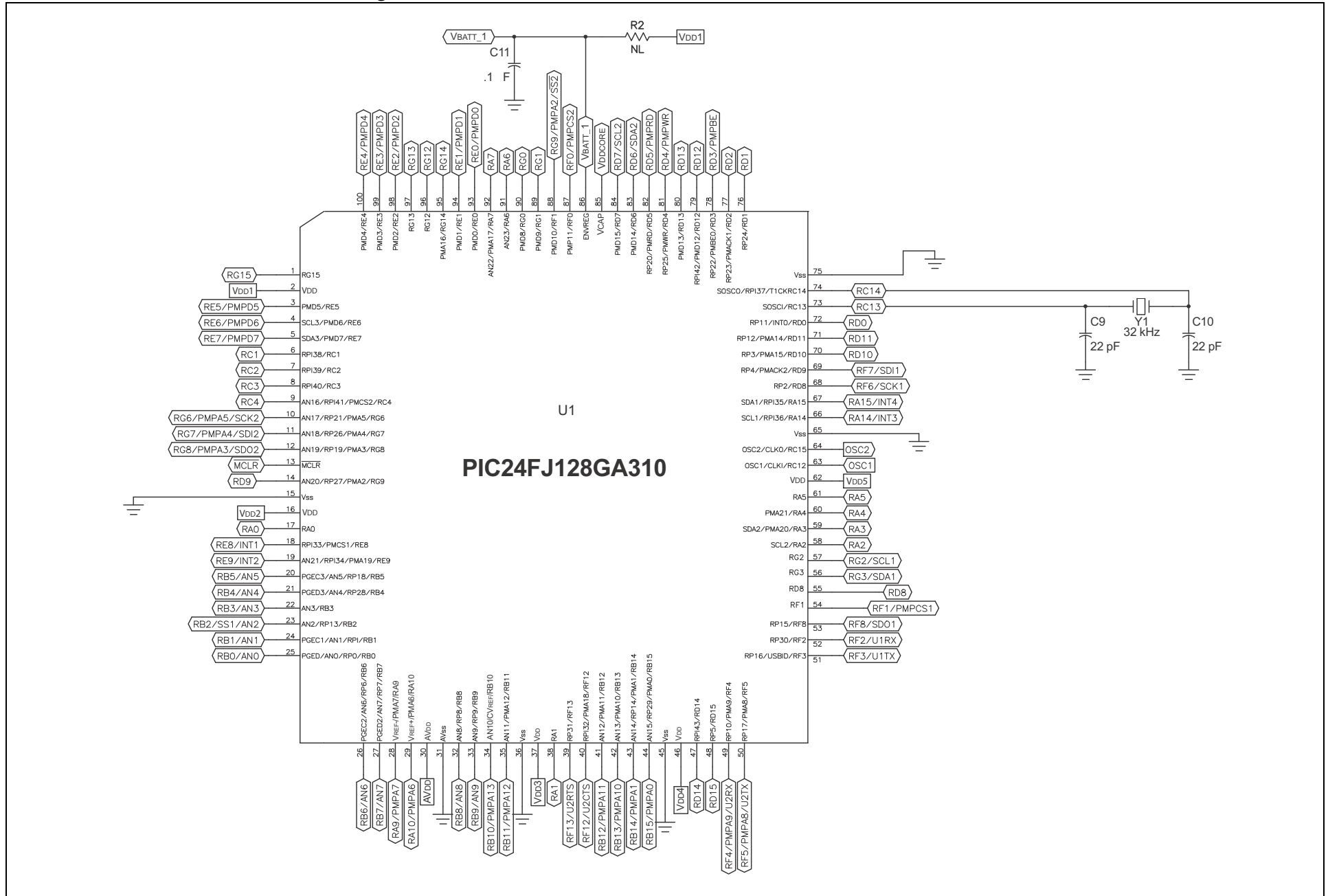

Introducing the LCD Explorer Demonstration Board

PIM for the PIC24FJ128GA310 Plug-in Module (Continued)

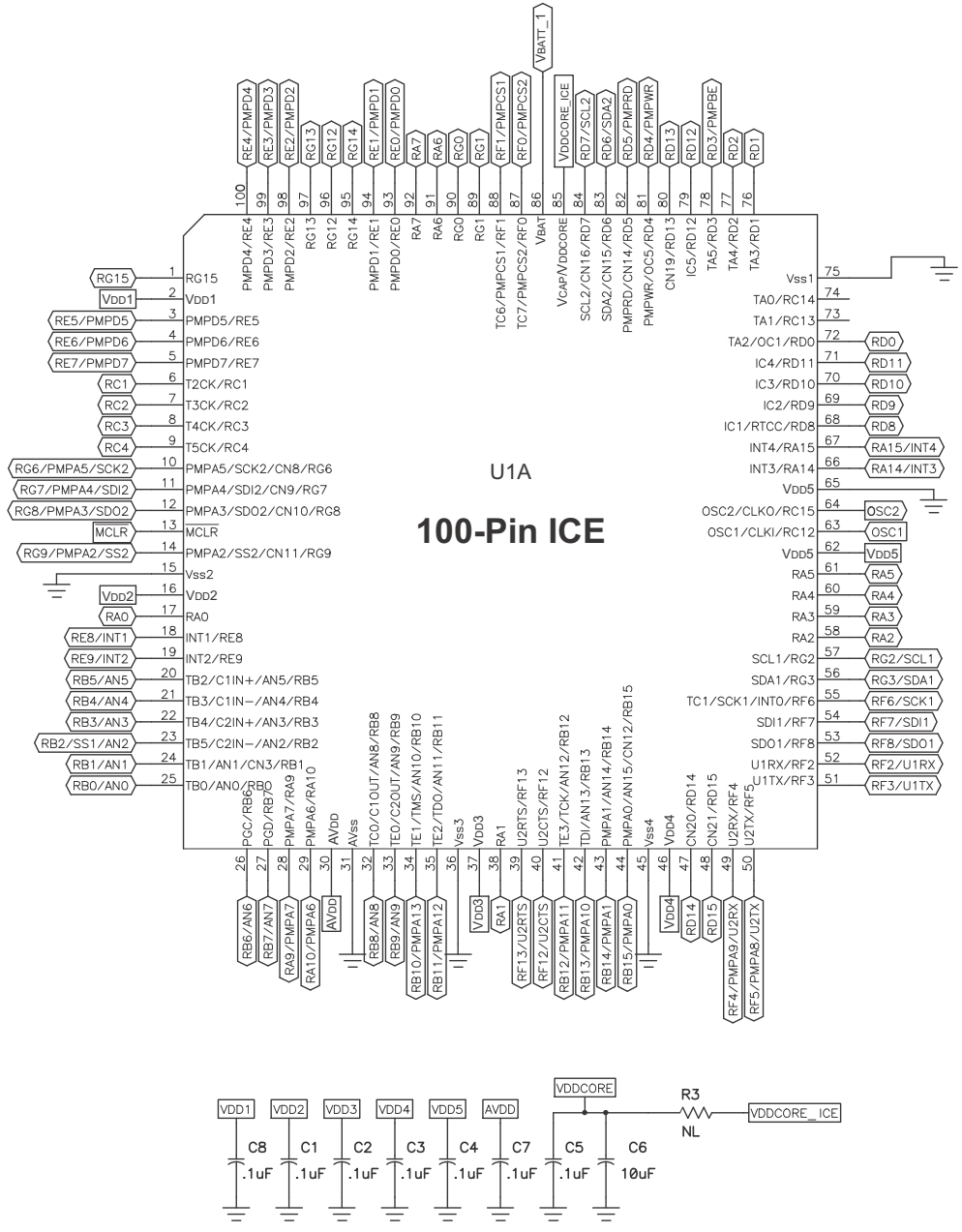

Introducing the LCD Explorer Demonstration Board

LCD Specifications/Connections

LCD Glass Specification

Type	STN, POSITIVE
Viewing Direction	6 o' Clock
Driving Method	1/8 Duty, 1/3 Bias VOP = 3V
Operating Temperature	-20°C to +70°C
Storage Temperature	-30°C to +80°C
Connection	PIN

LCD Segment Connection

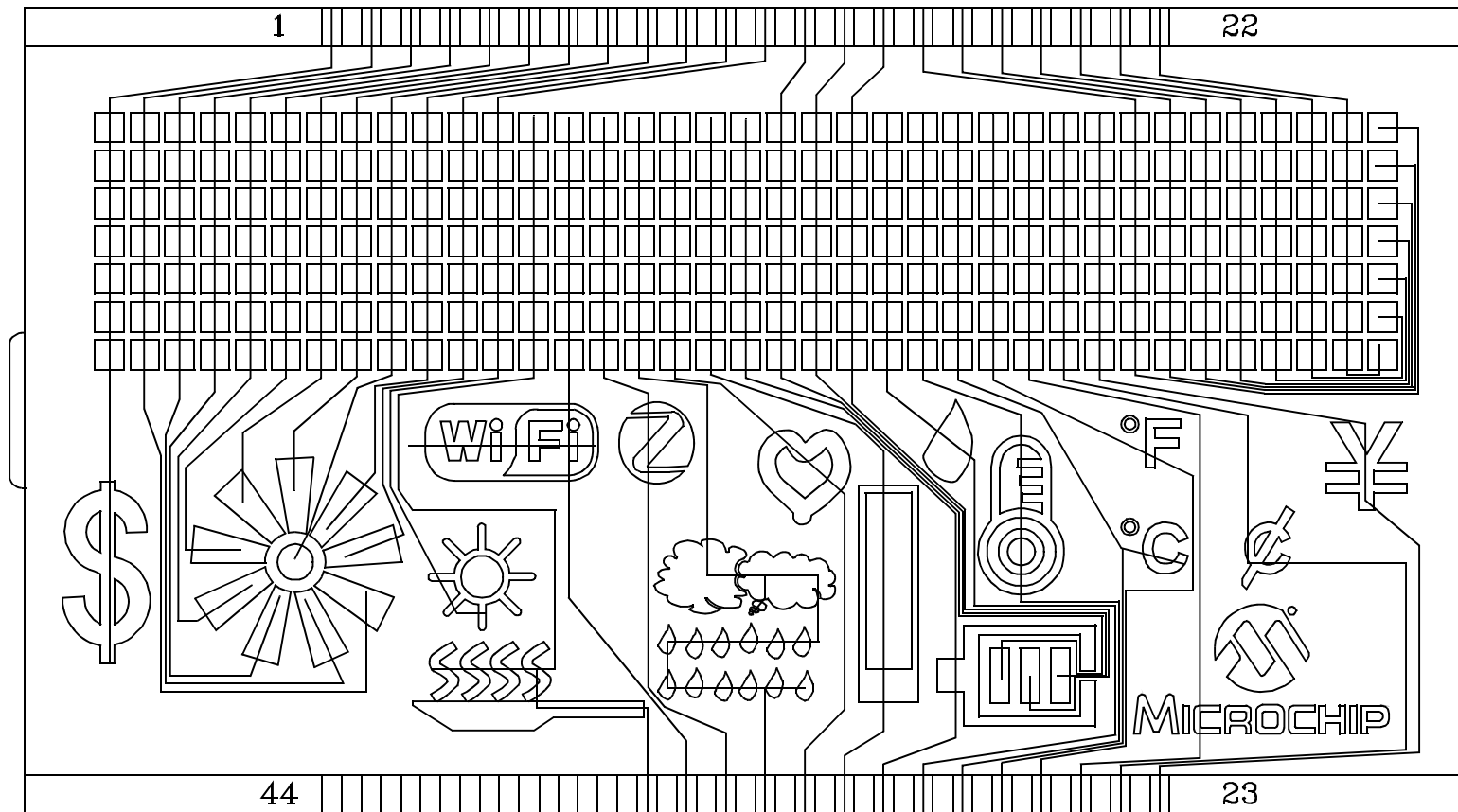

Introducing the LCD Explorer Demonstration Board

LCD Connections/COM vs. Segments

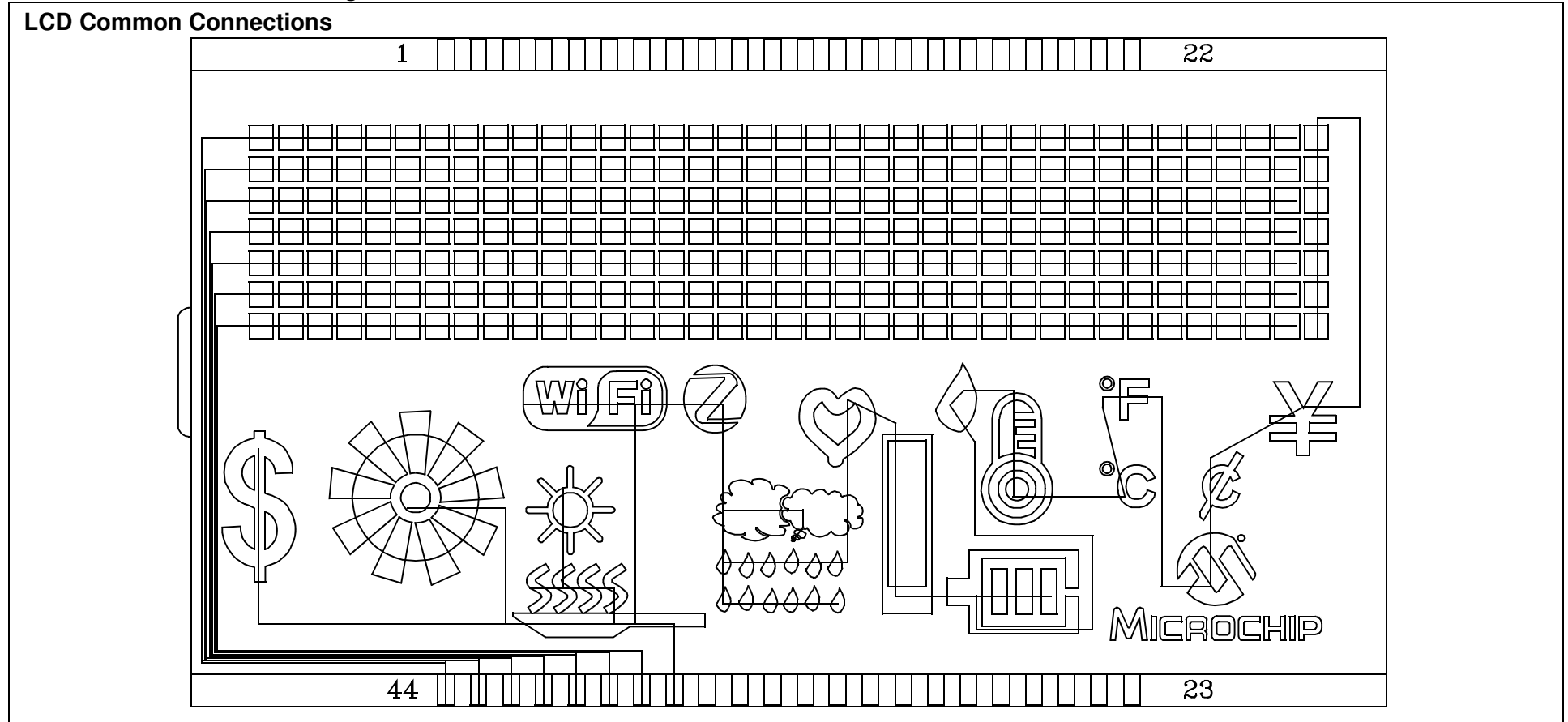

COM vs. Segment Table

PIN	1	2	3	4	5	6	7	8	9	10	11	12	13	14	15	16	17	18	19	20	21	22	23	24	25	26	27	28	29	30	31	32	33	34	35	36	37	38	39	40	41	42	43	44		
COM1	1A	2A	3A	4A	5A	6A	7A	8A	9A	10A	11A	12A	20A	21A	22A	30A	31A	32A	33A	34A	35A	36A	29A	28A	27A	26A	25A	24A	23A	19A	18A	17A	16A	15A	14A	13A	\	\	\	\	\	\	\	\	COM1	
COM2	1B	2B	3B	4B	5B	6B	7B	8B	9B	10B	11B	12B	20B	21B	22B	30B	31B	32B	33B	34B	35B	36B	29B	28B	27B	26B	25B	24B	23B	19B	18B	17B	16B	15B	14B	13B	\	\	\	\	\	\	\	\	COM2	\
COM3	1C	2C	3C	4C	5C	6C	7C	8C	9C	10C	11C	12C	20C	21C	22C	30C	31C	32C	33C	34C	35C	36C	29C	28C	27C	26C	25C	24C	23C	19C	18C	17C	16C	15C	14C	13C	\	\	\	\	\	\	COM3	\	\	
COM4	1D	2D	3D	4D	5D	6D	7D	8D	9D	10D	11D	12D	20D	21D	22D	30D	31D	32D	33D	34D	35D	36D	29D	28D	27D	26D	25D	24D	23D	19D	18D	17D	16D	15D	14D	13D	\	\	\	\	COM4	\	\	\	\	
COM5	1E	2E	3E	4E	5E	6E	7E	8E	9E	10E	11E	12E	20E	21E	22E	30E	31E	32E	33E	34E	35E	36E	29E	28E	27E	26E	25E	24E	23E	19E	18E	17E	16E	15E	14E	13E	\	\	\	COM5	\	\	\	\		
COM6	1F	2F	3F	4F	5F	6F	7F	8F	9F	10F	11F	12F	20F	21F	22F	30F	31F	32F	33F	34F	35F	36F	29F	28F	27F	26F	25F	24F	23F	19F	18F	17F	16F	15F	14F	13F	\	\	COM6	\	\	\	\	\		
COM7	1G	2G	3G	4G	5G	6G	7G	8G	9G	10G	11G	12G	20G	21G	22G	30G	31G	32G	33G	34G	35G	36G	29G	28G	27G	26G	25G	24G	23G	19G	18G	17G	16G	15G	14G	13G	\	COM7	\	\	\	\	\	\		
COM8	T1	T2	T3	T4	T5	T6	T7	T8	T9	T10	T11	T12	T20	T21	T22	37A	37B	37C	37D	37E	37F	37G	T29	T28	T27	T26	T25	T24	T23	T19	T18	T17	T16	T15	T14	T13	COM8	\	\	\	\	\	\	\		

Introducing the LCD Explorer Demonstration Board

Glass Layout with the Pixel Name/Numbering

