

CONTACT ORIENTATION ON ROLL
(4000PCS/COIL)

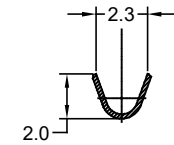

SECTION B-B

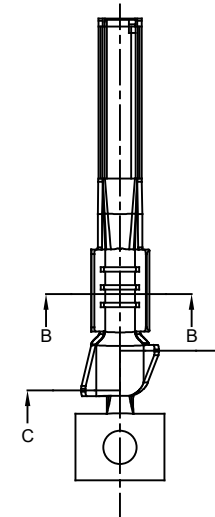
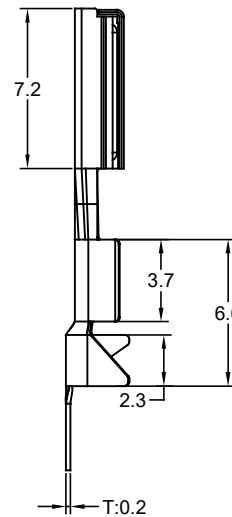
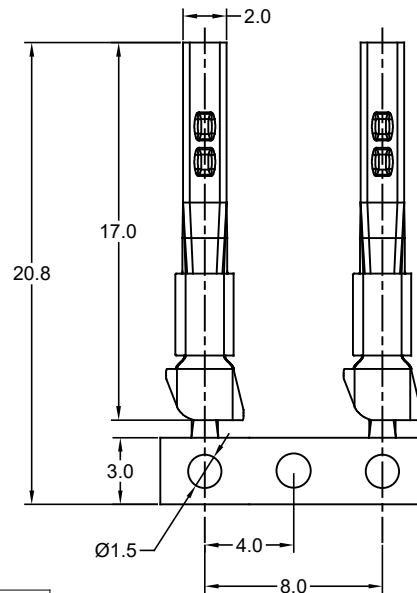
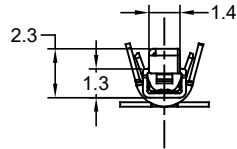
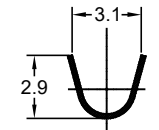

SECTION C-C

REVISIONS					
REV	ECO	DESCRIPTION	DATE	BY	APPR
A1	-	RELEASED DRAWING	May-15-2019	Flan	Tommy
A2	-	UPDATE DRAWING	Aug-9-2019	Flan	Tommy
A3	-	UPDATE DRAWING	Jun-29-2020	Ronald	Tommy

NOTES: (UNLESS OTHERWISE SPECIFIED)

1. MATERIAL:
 - 1.1. CONTACT: COPPER ALLOY.
2. SPECIFICATIONS:
 - 2.1 CURRENT RATING: 5A MAX.
 - 2.2 TERMINATION TYPE: CRIMPING.
 - 2.3 WIRE RANGE: 20~22AWG.
 - 2.4 WIRE INSULATION DIA (MAX): Ø1.8mm.
3. RoHS COMPLIANT.
4. ALL DIMENSIONS ARE FOR REFERENCE USE ONLY.

P/N	CONTACT PLATING (* MATING AREA ONLY)
SC000572T	TIN PLATING OVER NICKEL.
SC000572N	NICKEL PLATING OVER COPPER.
SC000572F	GOLD FLASH PLATING OVER NICKEL.
SC000572G5	* 5µ"GOLD PLATING OVER NICKEL.
SC000572G10	* 10µ"GOLD PLATING OVER NICKEL.
SC000572G15	* 15µ"GOLD PLATING OVER NICKEL.
SC000572G30	* 30µ"GOLD PLATING OVER NICKEL.

QUANTITY	PART NUMBER	DESCRIPTION	ITEM
MATERIALS LIST			
UNLESS OTHERWISE SPECIFIED: 1) All dimensions are in metric(mm). 2) Tolerances are as follows: 1 PL DEC ±0.30 Fractions ±1/64 2 PL DEC ±0.15 Angles ±1° 3) Note reference =		SIGNATURES	DATE
MATERIAL SPECIFICATIONS:		DRAWN: Ronald	Jun-29-2020
PROCESS SPECIFICATIONS:		CHECKED: Flan	Jun-30-2020
NEXT ASSY:		ENGINEER:	APPROVAL: Tommy
		CUSTOMER:	Jun-30-2020
		THIS DRAWING IS SUPPLIED FOR INFORMATION ONLY. DESIGN FEATURES, SPECIFICATIONS AND PERFORMANCE DATA SHOWN HEREON ARE THE PROPERTY OF THE AMPHENOL CORPORATION. NO RIGHTS OF REPRODUCTION ARE IMPLIED. ALL DIMENSIONS ARE SUBJECT TO NORMAL MANUFACTURING VARIATIONS.	
SCALE: NONE	SIZE: B C-	DWG NO: SC000572x	REVISION: A3
SHEET 1 OF 1			

TITLE: DURALOK ATV SOCKET CONTACT STAMPED, 20-22AWG DWG NO: SC000572x REV: A3 SH: 1 OF 1