

DASH NUMBER	CABLES ACCOMMODATED	A MAX	ASSEMBLE PER
-201	M17/176-00002	1.80	TAI-166
-202	TWC-78-1		
-203	TWC-124-1A		
-204	10602, RAYCHEM		
-205	TWAC-78-1F2		
-206	7826D0130, RAYCHEM		
-207	83310 BELDEN		
-208	202-3927, MICRODOT		
-209	202-3942, MICRODOT		
-210	8451 BELDEN		
-211	202-3934 MICRODOT	1.55	TAI-138
-212	2524E0114, RAYCHEM		
-213	TWC-78-2		
-214	TWC-124-2		
-215	BL-982 TIMES		
-216	BL-1242 TIMES		
-217	GC875TM24H, GRUMMAN	1.80	TAI-166
-218	EPD221888, RAYCHEM		
-219	2526D1114, RAYCHEM		
-220	GC875RRI, GRUMMAN		
-221	10614, RAYCHEM		
-222	10613, RAYCHEM		
-223	HMS2-1149, HUGHES		
-224	TWCP-124-3		
-225	PS665PL, PRIME STOCK	1.55	TAI-138

DATA CONTAINED IN THIS DOCUMENT IS PROPRIETARY TO TROMPETER ELECTRONICS INC. AND SHALL NOT BE DISCLOSED, COPIED OR USED FOR PROMOTION OR MANUFACTURE WITHOUT EXPRESS WRITTEN PERMISSION.

REVISIONS

REV	DESCRIPTIONS	DATE	APPROVED
R	REVISED PER ECO 16929	6/4/09	MMEX

DASH NUMBER	CABLES ACCOMMODATED	A MAX	ASSEMBLE PER
-301	GC875GCI, GRUMMAN	1.80	TAI-168
-302	GC875GB1, GRUMMAN 5022E5111, RAYCHEM		
-303	7528A5314, RAYCHEM		
-304			
-305	M17/177-00001 295-3804 MICRODOT		
-306	TRC-50-2 M17/134-00002		
-307	TRC-75-1		
-308	TRC-75-2		
-309	TRC-50-1		

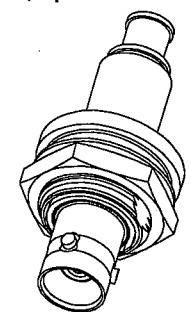

SCALE 1/1

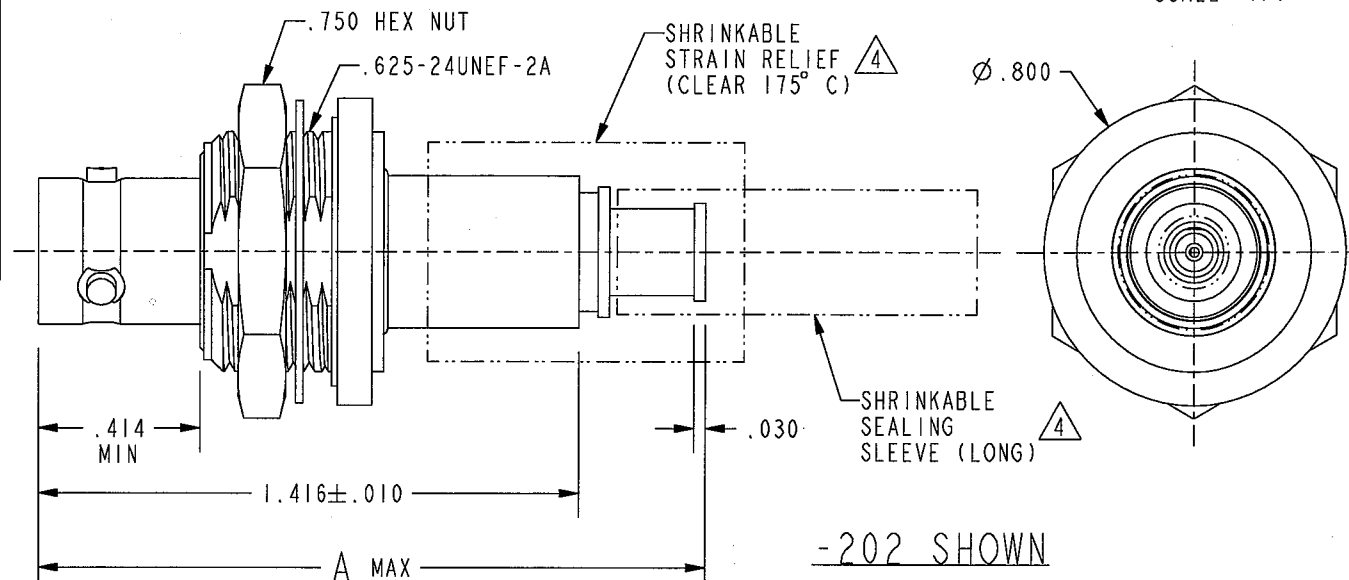

5. EXAMPLE OF COMPLETE MODEL NUMBER:

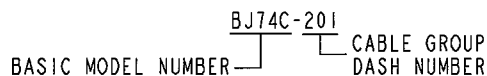

4 I SHRINKABLE STRAIN RELIEF AND/OR SHRINKABLE SEALING SLEEVE SUPPLIED LOOSE AS FOLLOWS:

- a. CABLE GROUPS -201 THROUGH -210, -217 THROUGH -303, -305, -307 AND -309

I SHRINKABLE STRAIN RELIEF (1.00 LONG)
 I SHRINKABLE SEALING SLEEVE (1.25 LONG)

- b. CABLE GROUPS -211 THROUGH -216, -224, -225, -306 AND -308

I SHRINKABLE STRAIN RELIEF (1.75 LONG)

3. MAXIMUM PANEL THICKNESS: .140

2. CONCENTRIC TWINAX/TRIAX TRB, INSULATED FULL CRIMP BULKHEAD MOUNT CABLE RECEPTACLE

1. FINISH: NICKEL

NOTES: UNLESS OTHERWISE SPECIFIED.

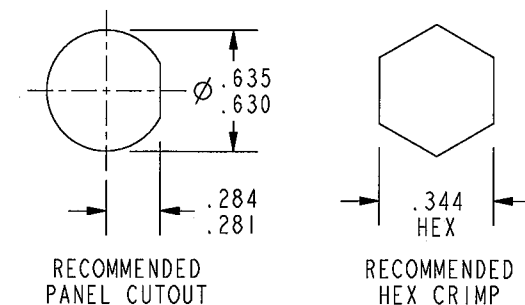

RECOMMENDED PANEL CUTOUT

RECOMMENDED HEX CRIMP

INTERPRET DRAWING PER MIL-STD-100. DIMENSIONS ARE IN INCHES AND INCLUDE FINISH THICKNESS UNLESS OTHERWISE SPECIFIED.		TOL: UNLESS SPECIFIED. .XX ± .02 .XXX ± .010 ANGLE ± 1°			
DRN	L. M.	5-26-09	MATERIAL:		
CHR	M. J.	5-29-09	FINISH:	BJ74C	
QUALITY				SIZE	CAGE CODE
MANUF				A	14949
APPROVED		5/29/09		DRAWING NO.	3-0201
PROT FILE NO.		3-0201	DO NOT SCALE DWG	DATE	11-11-86
NEXT ASSY				REV.	R
				SHEET	1