

Transfer or duplication of this document as well as the utilisation or communication of its content are not permitted unless express consent is granted. Violations give rise to claims for damages. All rights reserved in case of patent, utility model or design patent registrations.

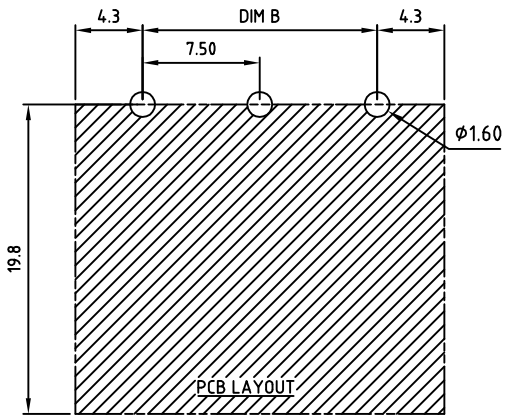
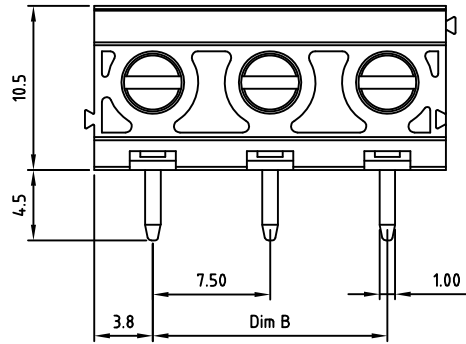
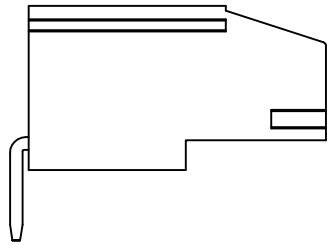
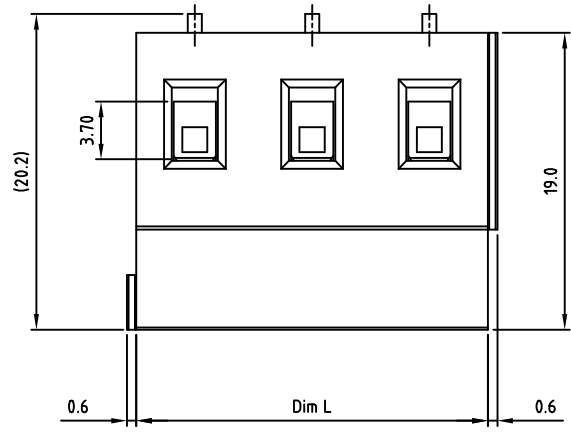

Technical data

1. Nominal voltage: 300V/20A
PITCH: 7.5mm
2. Connection capacity:
AWG 30-12
3. Insulation Withstanding Voltage:
AC 1600V/MIN
4. Insulation Resistance:
1000MΩ or more at DC500V
5. Tightening torque:
4.3Lb-In (5.0kgf.cm / 0.5N.m)
6. Screw thread: M3
7. Stripping length: 7-8mm
8. Operating temperature range: -40°C ~ 115°C
Soldering temperature: 250±10°C / 5s
9. Undimensioned Tolerances:

Dim.L = P x 7.5		
Dim.B = (P - 1) x 7.5		
P = number of poles (02-16P)		
0-30mm	Dim B	Dim L
over 30mm-60mm	±0.15	±0.20
over 60mm-90mm	±0.20	±0.25
over 90mm	±0.25	±0.30
	±0.30	±0.40

10. Safety approval:
11. RoHS Compliance

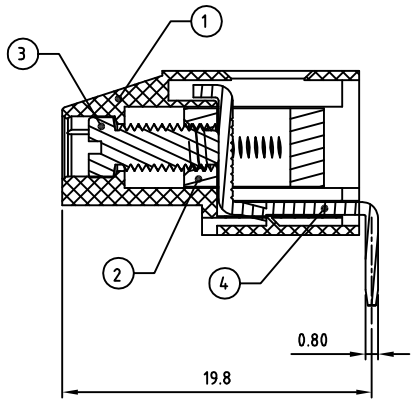

Part No.:

OSTVJXX4150

No. of Poles	COLOR
02 2 Poles	0: Black
03 3 Poles	2: Red
...	3: Orange
24 24 Poles	4: Yellow
	5: Green (Standard)
	6: Blue
	8: Grey

Nonstandard colors
Mins could apply

4	CONTACT	BRASS	Tin PLATED	P	
3	SCREW	STEEL	M3x0.5, Zn Plated	P	
2	CAGE	BRASS	M3x0.5, Ni PLATED	P	
1	BODY	PA66 UL94V-0	ALL COLOR	1	
ITEM	NAME OF PART	MATERIAL	NOTES	Q'TY	
DWG	WF. Zhang	DATE 2017.12.05	UNITS: MM	SHEET: 1 OF 1	Tolerance
CHK.	WF. Zhang	DATE 2018.05.22	SCALE: NONE 3:1 (:)	REV: A	X. ±0.50
APP.		DATE	TITLE: OSTVJ 7.5 Series 2-Interlock 90D "J" Slot Screw(H=19.0mm)		X.XX ±0.30
			PART NO. OSTVJXX4150		X* ±1°
			DWG NO. OSTVJXX4150.dwg		

⚠				
SIGN	DESCRIPTION	CHK.	DATE	



ON-SHORE TECHNOLOGY, INC.