

General dimension tolerance :  $\pm 0.5$

Shaft position  
will be at random.

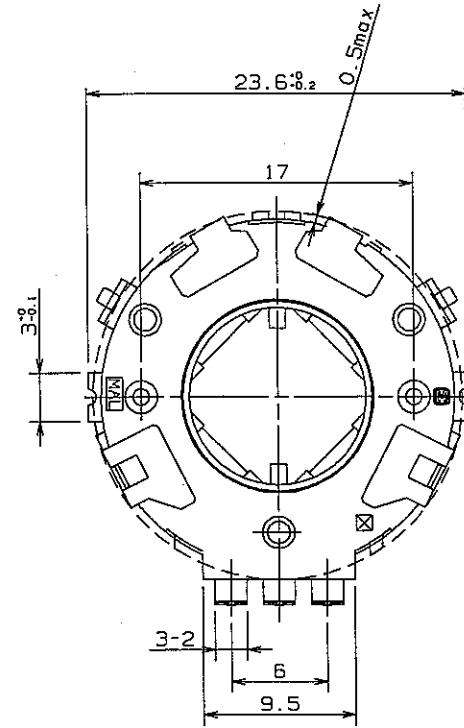

Section A-A

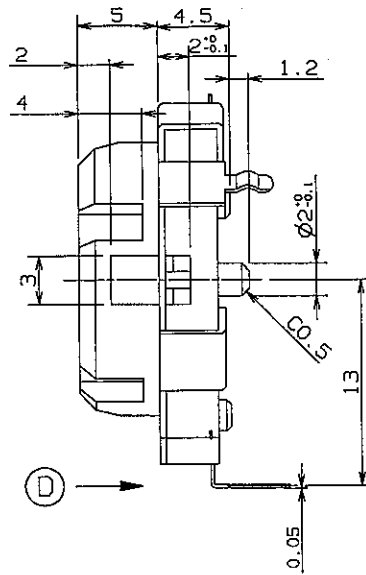
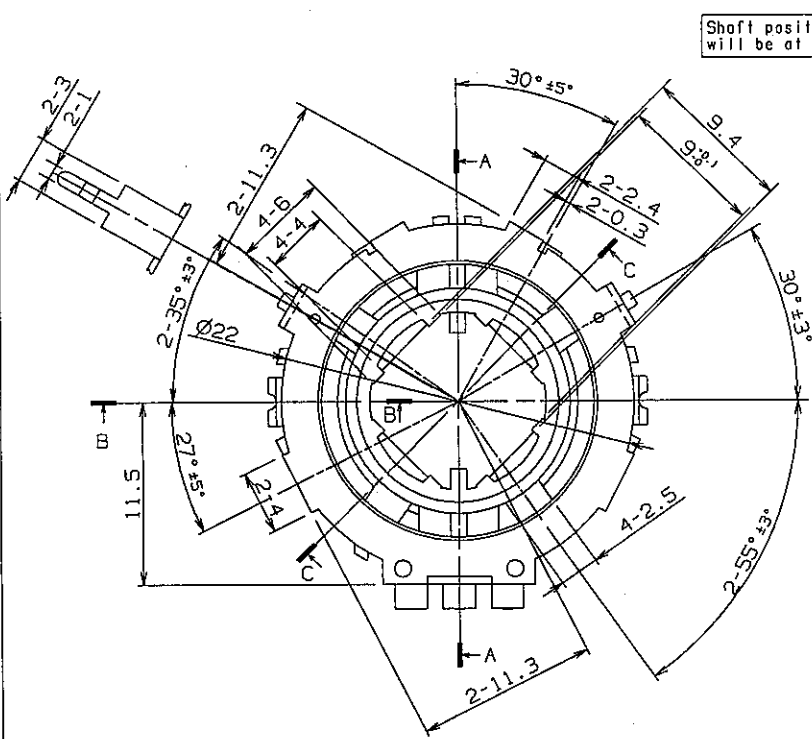
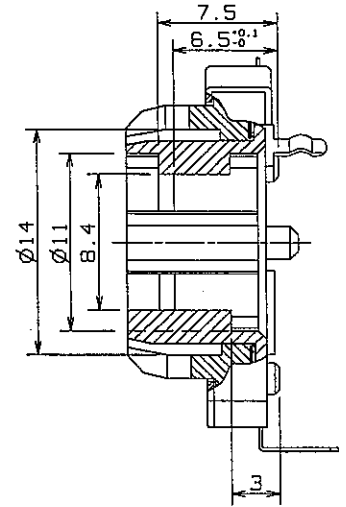

Section C-C

Section B-B

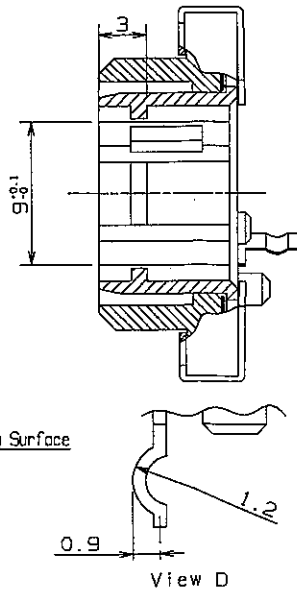
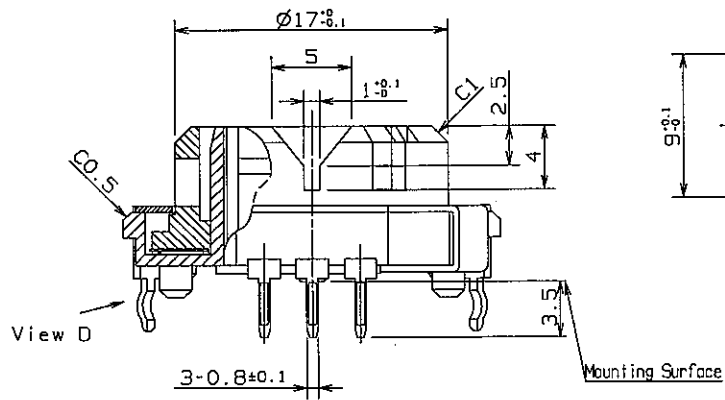

View from direction D

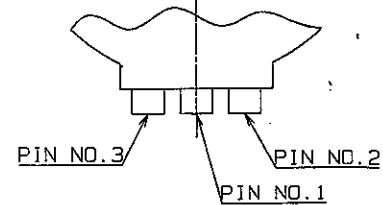

PIN NO.1 : COM.  
PIN NO.2 : Output signal A  
PIN NO.3 : Output signal B

P.C.B piercing plan

View from mounting side  
Tolerance= $\pm 0.05$   
P.C.B thickness  $t=1.6$

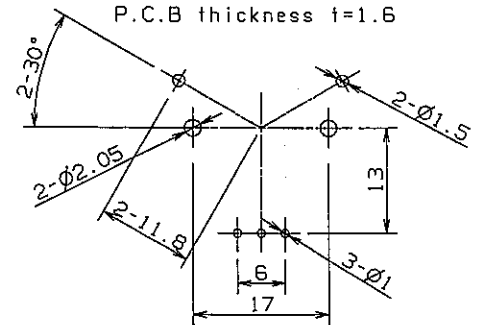

DESIGN	JARIAH	14.2.03	NAME		
DRAW	JARIAH	14.2.03	CENTER SPACE ENCODER	ISSUE	REVISIONS
CHECK			TYPE NO.	DRAWING NO.	
APPROVAL			EVQ 1WF 002 10B	REFERENCE ONLY	1/8

**THIRD ANGLE PROJECTION**

ALL DIMENSIONS ARE IN MILLIMETERS.

DO NOT SCALE DRAWING

General dimension tolerance : ±

General :

- 1) Operating temperature range : -40° - +85°C
- 2) Storage temperature range : -40° - +85°C
- 3) Application : This application is applied to low current circuit of electrical equipment
- 4) Outline and Dimension : See attached product drawing
- 5) Power rating : DC10V : 1mA

1 Electrical Specification :

- 1.1) Output signal : A,B 2 signals.(Output of phase difference)
- 1.2) Output resolution : 10 Pulse / 360°
- 1.3) Contact resistance between terminals : 1 Ω max.
- 1.4) Detent position : Output between Com. and A is stable ON or OFF. Output between Com. and B is stable ON or OFF.
- 1.5) Insulation resistance : 50 MΩ min. (At D.C.250V)  
(Between all terminals and bracket)
- 1.6) Withstand voltage : A.C 300V, 1 min.  
(Between all terminals and bracket)
- 1.7) Bouncing noise t1,t2 : 8 ms max.(Passing time between 3.5V and 1.5V)  
(Measurement circuit diagram 1.)  
(At rotation speed 20r/min)
- 1.8) Chattering noise t3 : 3 ms max. (Passing time over 3.5V.)

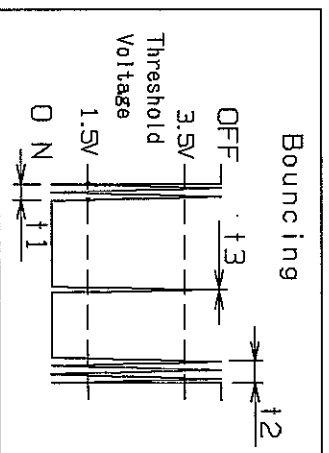

NAME	CENTER SPACE ENCODER		ISSUE	REVISIONS	DATE
TYPE NO.	EVD 1WF 002 10B	DRAWING NO.	REFERENCE ONLY		2/8

THIRD ANGLE PROJECTION

ALL DIMENSIONS ARE IN MILLIMETERS.

DO NOT SCALE DRAWING

General dimension tolerance : ±

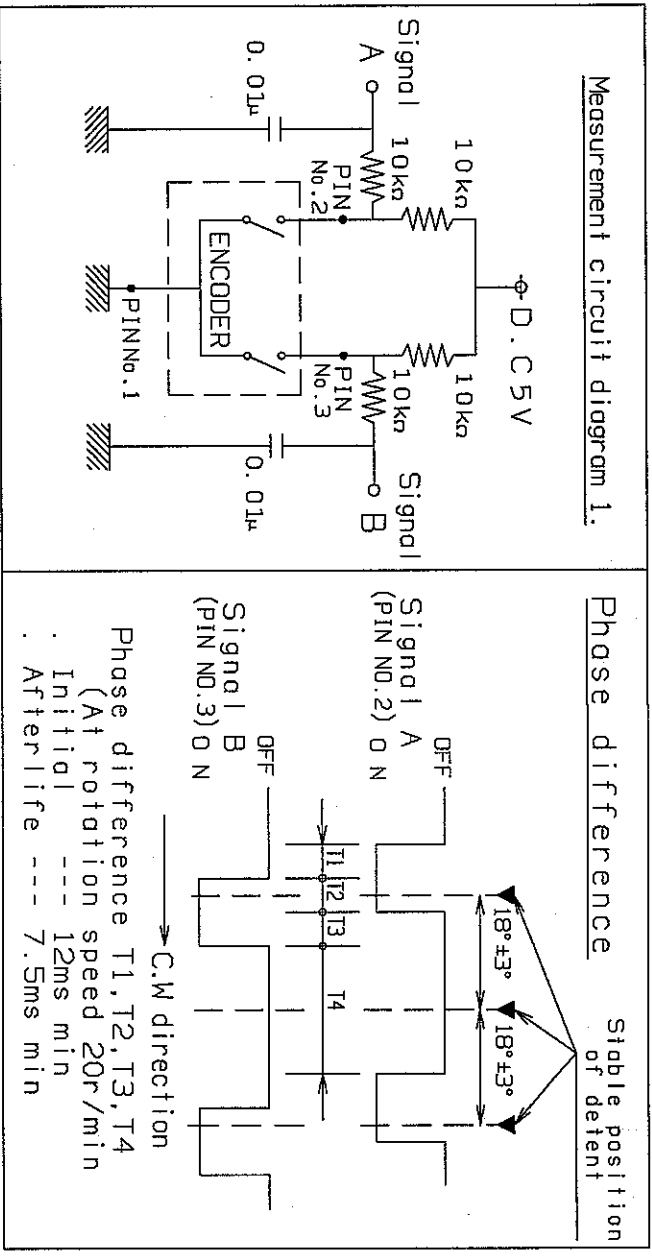

2) Mechanical Specification:

- 2.1) Shaft rotation angle : 360° (Endless)
- 2.2) Shaft pull-push strength : 40 N (4kgf) for 15s
- 2.3) Shaft play
  - Radial play : ±0.3mm max. <3mN.m(300gf.cm) weighting>
  - Thrust play : ±0.4mm max. <3N(300gf) weighting.>
- 2.4) Shaft rotation torque (Detent torque) : 3.0 to 9.0mN.m(30 to 90gf.cm)(at 5-35°C)
- 2.5) Detent point : 20detent points.  
 (Each detent angle : 18°±3° Excepting shaft rotation play.)

NAME	CENTER SPACE ENCODER	
	ISSUE	REVISIONS
TYPE NO.	EVO 1WF 002 10B	DRAWING NO.
		REFERENCE ONLY
		DATE
		3/8

THIRD ANGLE PROJECTION

ALL DIMENSIONS ARE IN MILLIMETERS.

DO NOT SCALE DRAWING

General dimension tolerance :  $\pm$ 

3 Environmental Specification:

ITEM	TEST CONDITION	SPECIFICATION
B.1 Operation life without load	50,000 cycles shall be performed continuously at speed rate 10 rpm  (One rotation in CW direction and one direction in CCW direction are counted as 1 cycle)	The product shall satisfy item 1.3, 1.5 and 1.6  No abnormality shall be found by appearance
B.2 Operation life with load	50,000 cycles shall be performed continuously at speed rate 10 rpm with load of 10MDC 1mA  (One rotation in CW direction and one direction in CCW direction are counted as 1 cycle)	
B.3 High temp.	85°C $\pm$ 2°c for 96 hours  After testing, the product shall be remained under normal room temperature and humidity for 1 hour before measuring	The product shall satisfy item 1.3, 1.5 and 1.6  No abnormality shall be found by appearance
B.4 Low temp.	-40°C $\pm$ 2°C for 96 hours  After testing, the product shall be remained under normal room temperature and humidity for 1 hour before measuring	The product shall satisfy item 1.3, 1.5 and 1.6  No abnormality shall be found by appearance
B.5 Humidity	40°C $\pm$ 2°C, 90-95%RH for 96 hours  After testing, the product shall be remained under normal room temperature and humidity for 1 hour before measuring	The product shall satisfy item 1.3, 1.5 and 1.6  No abnormality shall be found by appearance

NAME	CENTER SPACE ENCODER		ISSUE		REVISIONS		DATE
TYPE NO.	EVD 1WF 002 10B		DRAWING NO.				
			REFERENCE ONLY				4/8

THIRD ANGLE PROJECTION

ALL DIMENSIONS ARE IN MILLIMETERS.

DO NOT SCALE DRAWING

General dimension tolerance : ±

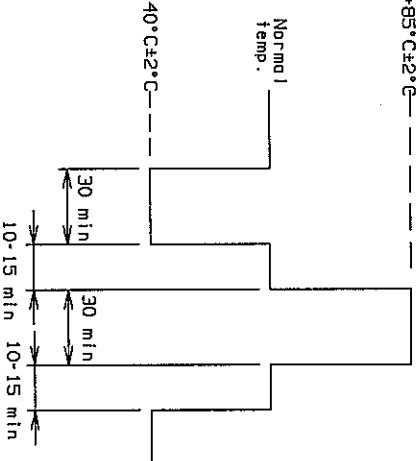
ITEM	TEST CONDITION	SPECIFICATION
3.6	<p>Temp. cycling</p> <p>5 cycles of below sequence shall be performed:</p> <p>+85°C±2°C-----</p>  <p>Normal temp.</p> <p>-40°C±2°C-----</p> <p>30 min</p> <p>30 min</p> <p>30 min</p> <p>10-15 min</p> <p>10-15 min</p> <p>After testing, the product shall be remained under normal room temperature and humidity for 1 hour before measuring</p>	<p>The product shall satisfy item 1.3, 1.5 and 1.6</p> <p>No abnormality shall be found by appearance</p>
3.7	<p>Humidity with load</p> <p>DC voltage 1.5 times as much as rated voltage shall be applied continuously between terminals at 60°C±2°C, 90-95RH% for 500 hrs</p> <p>After testing, the product shall be remained under normal room temperature and humidity for 1 hour before measuring</p>	<p>The product shall satisfy item 1.3, 1.5 and 1.6</p> <p>No abnormality shall be found by appearance</p>
3.8	<p>Vibration</p> <p>The product shall be tested as under following condition and measure after testing:</p>	<p>The product shall satisfy item 1.3, 1.5 and 1.6</p> <p>No abnormality shall be found by appearance</p>

- 1) Vibration frequency range : 10-55Hz
- 2) Total amplitude : 10mm
- 3) Sweep ratio : 5mm/10Hz
- 4) Method of changing sweeping : logarithmic/linear
- 5) Vibration frequency : approx. 1 min
- 6) Direction of vibration : 3 directions
- 7) Time : 2 hours each (total 6 hours)

NAME	CENTER SPACE ENCODER	
TYPE NO.	EVD 1WF 002 10B	DRAWING NO. REFERENCE ONLY
	REVISIONS	DATE
		5/8

THIRD ANGLE PROJECTION

ALL DIMENSIONS ARE IN MILLIMETERS.

DO NOT SCALE DRAWING

General dimension tolerance : ±

< Application Notes >

- 1 Avoid storing the products in a place at high temperature, high humidity and in corrosive gases. The storage period shall be 6 months and must be sealed in plastic bag
- 2 Be careful to avoid excessive force when handling products, especially when inserting into P.C.B so as to avoid deformation of terminals.
- 3 The encoder's pulse count method should be designed with taking operating speed, sampling time, and the design of the micro computer software, etc. into consideration.
- 4 Prohibited items on fire and smoking
  - Absolutely void use of a encoder beyond its rated range because it may cause a fire. If misuse or abnormal use may result in conditions which the encoder is used out of its rated range, take proper measures such as current interruption using a protective circuit.
  - The grade of nonflammability for resin used in encoders is "94HB," which is based on UL94 Standards (flammability test for plastic materials).
  - Prohibit use in a location where a spreading fire may be generated or prepare against a spreading fire.
- 5 For use in equipment for which safety is requested

Although care is taken to ensure encoder quality, inferior characteristics, short circuits, open circuits are some problems that might be generated. To design a set which places maximum emphasis on safety, review the effect of any single fault of a encoder in advance and perform virtually fail-safe design to ensure maximum safety by:

  - preparing a protective circuit or a protective device to improve system safety, and
  - preparing a redundant circuit to improve system safety so that the single fault of encoder dose not cause a dangerous situation.
- 6 If the load is applied to the terminals during soldering it might cause failure in electrical performance.

NAME	ISSUE		REVISIONS		DATE
	TYPE NO.	DRAWING NO.			
CENTER SPACE ENCODER	EVD 1WF 002 10B	REFERENCE ONLY			6/8

General dimension tolerance : ±

Soldering conditions

- 1) When dipping in solder, apply the flux by the foaming method under the conditions mentioned below.  
 Specific gravity of flux --- 0.83±0.005  
 Flux foaming time ----- Within 5 s  
 Flux foaming level ----- 1/2t or less

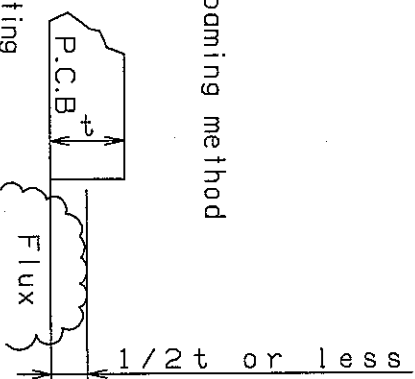

- 2) After flux application, sufficiently dry the flux by preheating under the conditions mentioned below.  
 Temperature ----- 90 ~ 100 °C (Ambient temp.)  
 Time ----- 50 ~ 70s
- 3) Soldering should be performed at 250°C or less within 3 sec. Soldering can be allowed twice only.
- 4) Conditions of P.C.B  
 Thickness ----- t=1.6  
 Material ----- Single side copper clad phenolic resin Laminates. \*  
 Mounting terminal hole ----- P.C.B. piercing plan.  
 \*) If you use Double side copper clad phenolic resin laminates, we would like to negotiate with you for the soldering conditions.
- 5) If the conditions (1)-(4) are satisfied, there will be no problems such as flux sucked up from terminals and electrical contact.  
 The product is open-type, being defenseless against spattered flux, and therefore special care should be taken when dipping in solder.  
 Particularly, care should be taken in the case of wiring such as jumper wire near the encoder body where flux is remaining. If flux is spattered to the product body, it may cause electrical contact or mechanical trouble.
- 6) When soldering by hand, the job should be performed at 350°C within 3 sec.

Notes :

- 1) Marking : (1) Our identification mark  (2) Date code

Handling of approval specification :

- 1 This specification specify for this item only. Please perform your approval testing in the actual application conditions beforehand.
- 2 Please return one copy of this specification with your approval stamp or signature to us. Otherwise, it might be happened that the item can not be supplied.
- 3 Writings in this specification are subject to change through precautions.

NAME	CENTER SPACE ENCODER		ISSUE		REVISIONS		DATE
TYPE NO.	EVQ 1WF 002 10B		DRAWING NO.		REFERENCE ONLY		7/8

THIRD ANGLE PROJECTION

ALL DIMENSIONS ARE IN MILLIMETERS.

DO NOT SCALE DRAWING

General dimension tolerance :  $\pm$

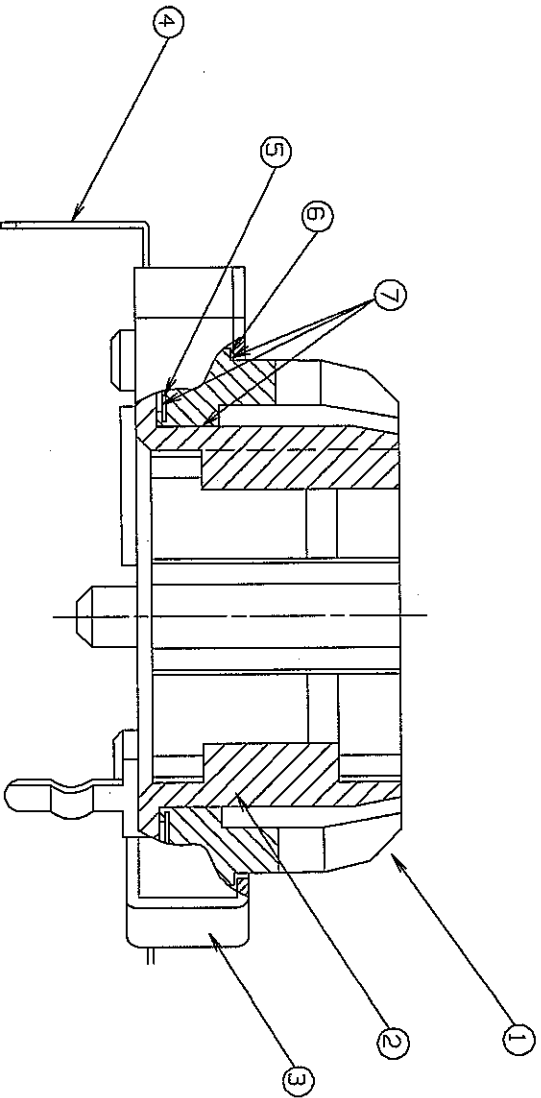

No.	Part Name	Material	Treatment
1	Shaft	Polycarbonate (Transparent)	_____
2	Case	PBT	_____
3	Cover	Steel Sheet	Zn-Ni plating
4	Terminal & Brush	Ni. Silver Strip	Ag Plating
5	Contact Plate	Brass	Ag Plating
6	Spring	Phosphor Bronze	_____
7	Grease	Silicon oil	_____

NAME		CENTER SPACE ENCODER	
TYPE NO.		EVD 1WF 002 10B	
ISSUE	DRAWING NO.	REVISIONS	DATE
	REFERENCE ONLY		8/8