

PROTECTION PRODUCTS

Description

TClamp[®]xx82S are specifically designed to provide secondary surge and ESD protection for G.Fast and other DSL circuit line drivers. These devices integrate low capacitance, surge-rated steering diodes with a high power transient voltage suppressor (TVS). The TVS utilizes snap-back or "crow-bar" technology to minimize device clamping voltage and features high surge current capability of 30A ($t_p=8/20\mu s$).

TClampxx82S capacitance is limited to 2.5pF maximum with a low typical capacitance variation over the operating voltage range. This ensures correct signal transmission on DSL lines. The biased bridge structure allows the device to be used in G.Fast, ADSL, and VDSL applications with with operating voltages of 8, 12, 20, and 24Vp-p.

TClampxx82S is in a 6-pin SOT-23 package. The leads are finished with lead-free matte tin. The flow-through package design simplifies PCB layout.

Circuit Diagram

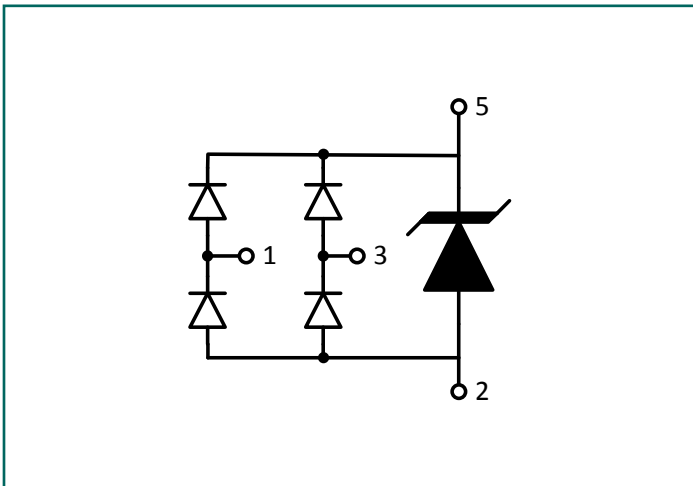

Features

- Transient Protection to
 - ♦ IEC 61000-4-2 (ESD) 30kV (Air), 30kV (Contact)
 - ♦ IEC 61000-4-4 (EFT) 2kV (5/50ns)
 - ♦ IEC 61000-4-5 (Lightning) 30A (8/20 μs)
- Bias diodes prevent charging of TVS capacitance
- Working Voltage Options: 8V, 12V, 20V, 24V
- Low Capacitance: 2.5pF Maximum
- Low Capacitance Variation (1V to V_{RWM})
- Solid-State Silicon-Avalanche Technology

Mechanical Characteristics

- JEDEC SOT-23 6L package
- Pb-Free, Halogen Free, RoHS/WEEE Compliant
- Lead Finish: Matte Tin
- Molding Compound Flammability Rating: UL 94V-0
- Marking : Marking Code + Date Code
- Packaging : Tape and Reel

Applications

- ADSLx / VDSLx Secondary Protection
- G.Fast Line Driver Secondary Protection
- VDSL2 Class-H Line Driver Secondary Protection
- Modems
- Access Equipment
- Central Office Equipment
- Customer Premise Equipment

Pin Configuration

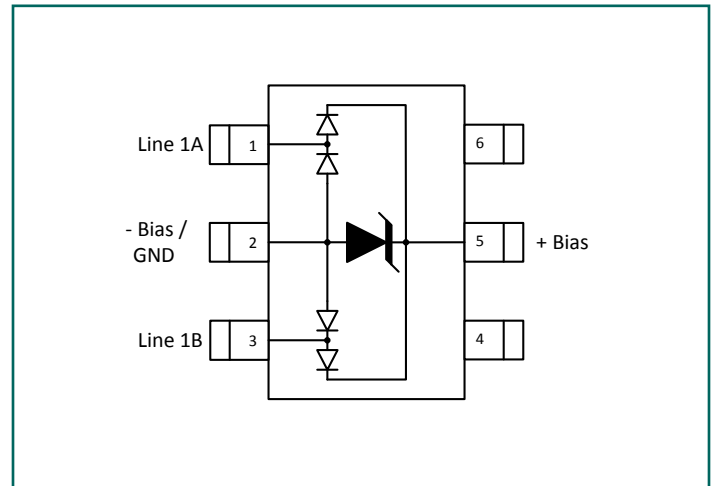

Absolute Maximum Ratings

Rating	Symbol	Value	Units
Peak Pulse Power (tp = 8/20μs)	P _{PK}	300	W
Peak Pulse Current (tp = 8/20μs)	I _{PP}	30	A
ESD per IEC 61000-4-2 (Contact) ^{(1), (3)}	V _{ESD}	±30	kV
Operating Temperature	T _J	-40 to +85	°C
Storage Temperature	T _{STG}	-55 to +150	°C

Electrical Characteristics (T=25°C unless otherwise specified)

TClamp0882S							
Parameter	Symbol	Conditions	Min.	Typ.	Max.	Units	
Reverse Stand-Off Voltage	V _{RWM}	-40°C to 85°C Pin 1 or 3 to Pin 2, Pin 1 to Pin 3			8	V	
Reverse Breakdown Voltage	V _{BR}	I _{BR} = 10mA, T = -40°C to 85°C Pin 1 to Pin 3	13.5	15.5	18	V	
Reverse Leakage Current	I _R	V _{RWM} = 8V	T = 25°C		0.01	0.100	μA
			T = 85°C		0.02	0.100	μA
Holding Current ⁽³⁾	I _H		50	125		mA	
Clamping Voltage ^{(2), (3)}	V _C	I _{PP} = 30A, tp = 1.2/50μs, 8/20μs Combination Waveform Pin 1 to Pin 3		9.5		V	
Breakover Voltage ⁽³⁾	V _{BO}	I _{BO} = 50mA Pin 1 to Pin 3			23	V	
Junction Capacitance	C _J	V _R = 0V, f = 1MHz Pin 1 to 3		1.2	2.5	pF	
Variation in Junction Capacitance ⁽³⁾	ΔC _J	V _R = 1V - 8V, f = 1MHz Pin 1 to Pin 3		0.15		pF	

Notes:

(1): ESD Gun return path to Ground Reference Plane (GRP)

(2): Measured using a 1.2/50us voltage, 8/20us current combination waveform, RS = 2 Ohms. Clamping is defined as the peak voltage across the device after the device snaps back to a conducting state.

(3): Guaranteed by design. Not production tested

Absolute Maximum Ratings

Electrical Characteristics (T=25°C unless otherwise specified)

TClamp1282S							
Parameter	Symbol	Conditions	Min.	Typ.	Max.	Units	
Reverse Stand-Off Voltage	V_{RWM}	-40°C to 85°C Pin 1 or 3 to Pin 2, Pin 1 to Pin 3			12	V	
Reverse Breakdown Voltage	V_{BR}	$I_{BR} = 10\text{mA}$, T = -40°C to 85°C Pin 1 to Pin 3	15.5	18.5	22	V	
Reverse Leakage Current	I_R	$V_{RWM} = 12\text{V}$	T = 25°C		0.01	0.100	μA
			T = 85°C		0.02	0.100	μA
Holding Current ⁽³⁾	I_H		50	125		mA	
Clamping Voltage ^{(2), (3)}	V_C	$I_{pp} = 30\text{A}$, $t_p = 1.2/50\mu\text{s}$, $8/20\mu\text{s}$ Combination Waveform Pin 1 to Pin 3		9.5		V	
Junction Capacitance	C_J	$V_R = 0\text{V}$, $f = 1\text{MHz}$ Pin 1 to 3	T = 25°C		1.2	2.5	pF
Variation in Junction Capacitance ⁽³⁾	ΔC_J	$V_R = 1\text{V} - 12\text{V}$, $f = 1\text{MHz}$ Pin 1 to Pin 3		0.15		pF	

Notes:

(1): ESD Gun return path to Ground Reference Plane (GRP)

(2): Measured using a 1.2/50us voltage, 8/20us current combination waveform, RS = 2 Ohms. Clamping is defined as the peak voltage across the device after the device snaps back to a conducting state.

(3): Guaranteed by design. Not production tested

Absolute Maximum Ratings

Electrical Characteristics (T=25°C unless otherwise specified)

TClamp2082S							
Parameter	Symbol	Conditions	Min.	Typ.	Max.	Units	
Reverse Stand-Off Voltage	V_{RWM}	-40°C to 85°C Pin 1 or 3 to Pin 2, Pin 1 to Pin 3			20	V	
Reverse Breakdown Voltage	V_{BR}	$I_{BR} = 10\text{mA}$, T = -40°C to 85°C Pin 1 to Pin 3	23	26.5	30	V	
Reverse Leakage Current	I_R	$V_{RWM} = 20\text{V}$	T = 25°C		0.01	0.100	μA
			T = 85°C		0.02	0.100	μA
Holding Current ⁽³⁾	I_H		50	125		mA	
Clamping Voltage ^{(2), (3)}	V_C	$I_{PP} = 30\text{A}$, $t_p = 1.2/50\mu\text{s}$, $8/20\mu\text{s}$ Combination Waveform Pin 1 to Pin 3		9.5		V	
Breakover Voltage ⁽³⁾	V_{BO}	$I_{BO} = 50\text{mA}$ Pin 1 to Pin 3			23	V	
Junction Capacitance	C_J	$V_R = 0\text{V}$, $f = 1\text{MHz}$ Pin 1 to 3					
			T = 25°C		1.2	2.5	pF
Variation in Junction Capacitance ⁽³⁾	ΔC_J	$V_R = 1\text{V} - 20\text{V}$, $f = 1\text{MHz}$ Pin 1 to Pin 3		0.4		pF	

Notes:

(1): ESD Gun return path to Ground Reference Plane (GRP)

(2): Measured using a 1.2/50us voltage, 8/20us current combination waveform, RS = 2 Ohms. Clamping is defined as the peak voltage across the device after the device snaps back to a conducting state.

(3): Guaranteed by design. Not production tested

Absolute Maximum Ratings

Electrical Characteristics (T=25°C unless otherwise specified)

TClamp2482S							
Parameter	Symbol	Conditions	Min.	Typ.	Max.	Units	
Reverse Stand-Off Voltage	V_{RWM}	-40°C to 85°C Pin 1 or 3 to Pin 2, Pin 1 to Pin 3			24	V	
Reverse Breakdown Voltage	V_{BR}	$I_{BR} = 10\text{mA}$, T = -40°C to 85°C Pin 1 to Pin 3	27	31	35	V	
Reverse Leakage Current	I_R	$V_{RWM} = 24\text{V}$	T = 25°C		0.01	0.100	μA
			T = 85°C		0.02	0.100	μA
Holding Current ⁽³⁾	I_H		50	125		mA	
Clamping Voltage ^{(2), (3)}	V_C	$I_{PP} = 30\text{A}$, $t_p = 1.2/50\mu\text{s}$, $8/20\mu\text{s}$ Combination Waveform Pin 1 to Pin 3		9.5		V	
Breakover Voltage ⁽³⁾	V_{BO}	$I_{BO} = 50\text{mA}$ Pin 1 to Pin 3			35	V	
Junction Capacitance	C_J	$V_R = 0\text{V}$, $f = 1\text{MHz}$ Pin 1 to 3					
Variation in Junction Capacitance ⁽³⁾	ΔC_J	$V_R = 1\text{V} - 24\text{V}$, $f = 1\text{MHz}$ Pin 1 to Pin 3			0.4	pF	

Notes:

(1): ESD Gun return path to Ground Reference Plane (GRP)

(2): Measured using a 1.2/50us voltage, 8/20us current combination waveform, RS = 2 Ohms. Clamping is defined as the peak voltage across the device after the device snaps back to a conducting state.

(3): Guaranteed by design. Not production tested

Typical Characteristics

Non-Repetitive Peak Pulse Power vs. Pulse Time

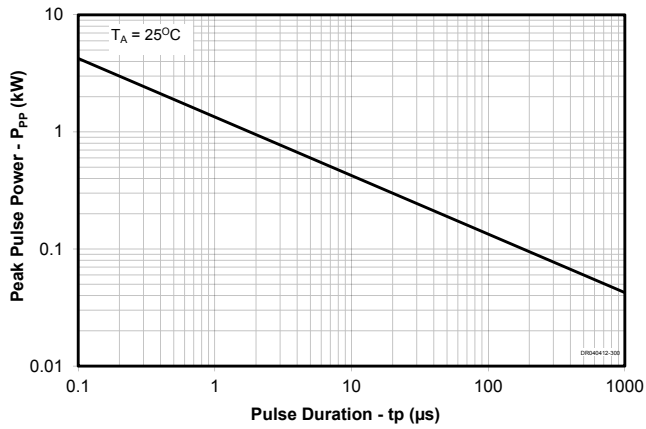

Power Derating Curve

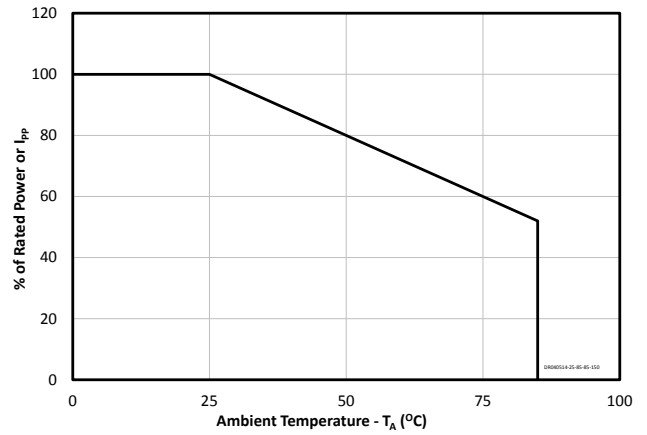

Clamping Characteristic (I/O to I/O, Pin 1-3)

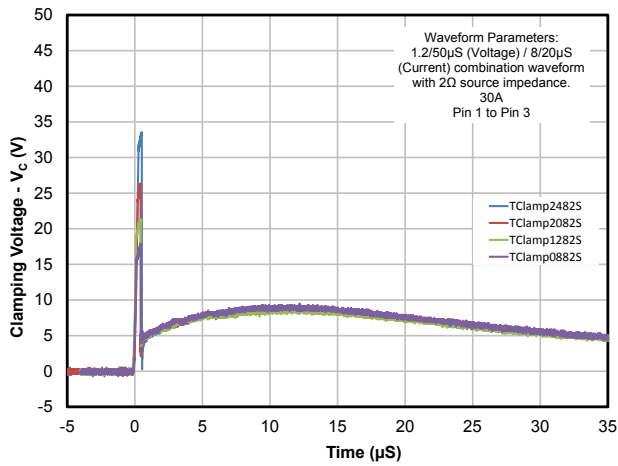

Clamping Characteristic (I/O to GND, Pin 1 or 3 to 2)

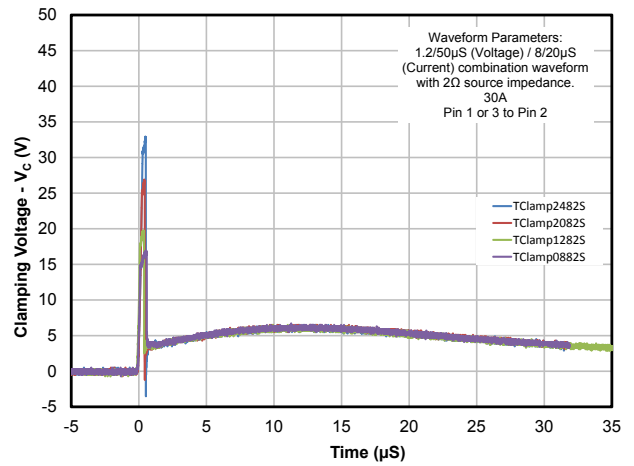

ESD Clamping (+8kV Contact per IEC 61000-4-2)

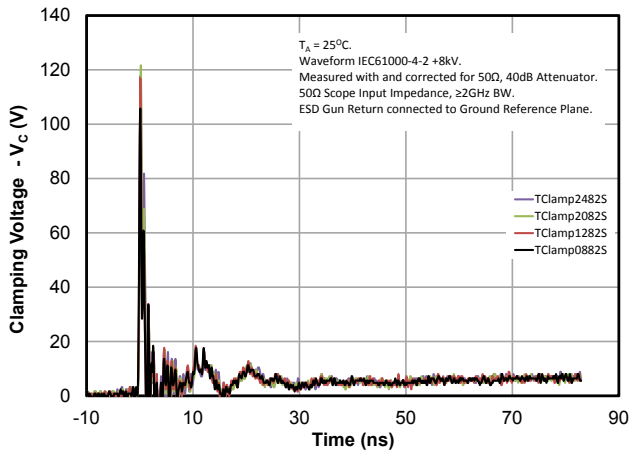

ESD Clamping (-8kV Contact per IEC 61000-4-2)

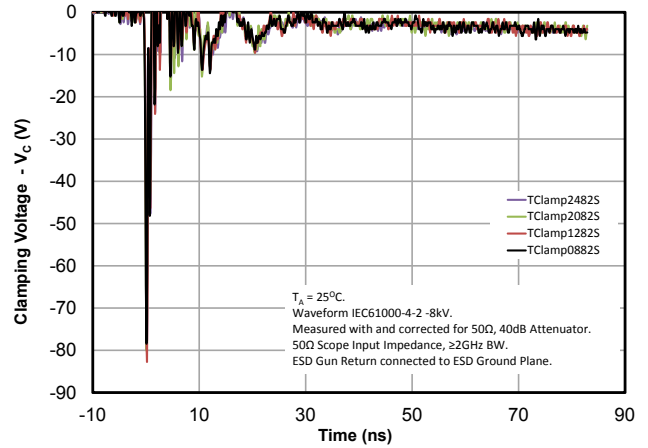

Typical Characteristics

TLP Characteristic

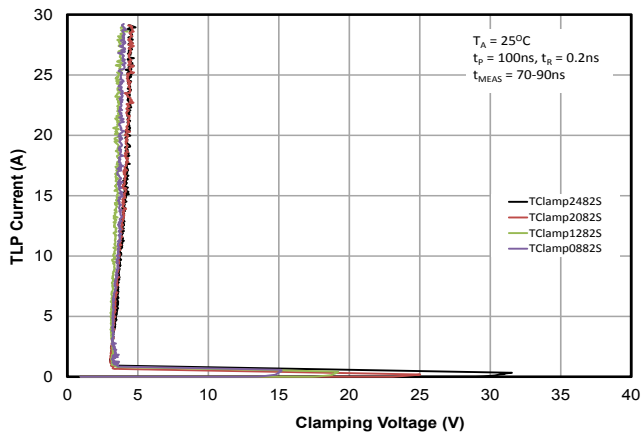

Capacitance vs. Reverse Voltage (Pin 1 to 3)

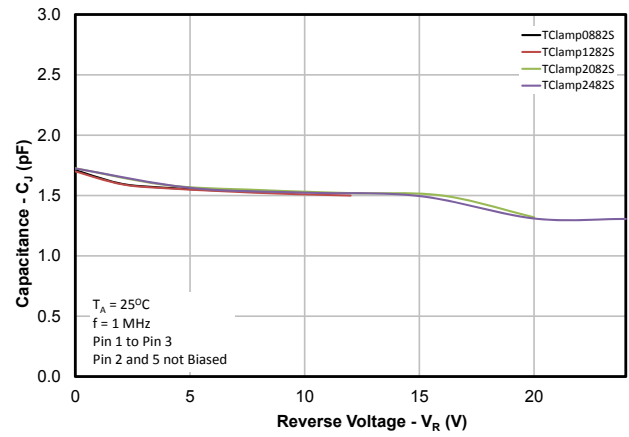

Capacitance vs. Reverse Voltage (Pin 1 or 3 to Pin 2)

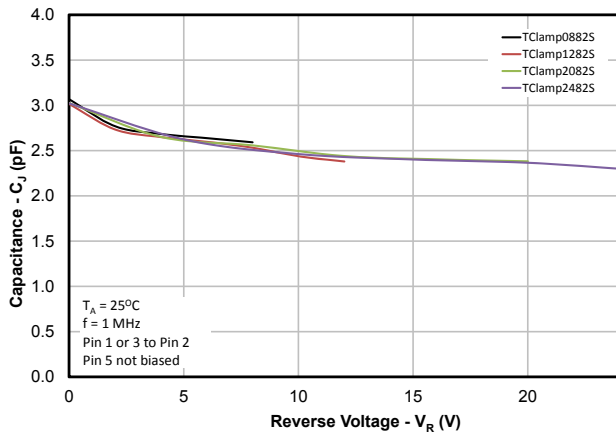

Applications Information

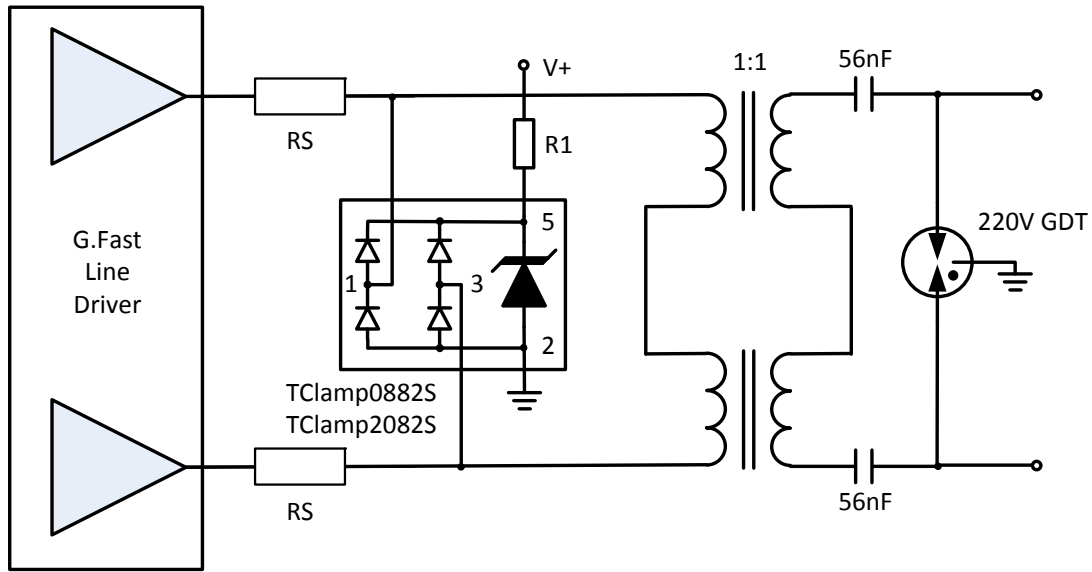

Figure 1 - Typical G.Fast Protection Circuit

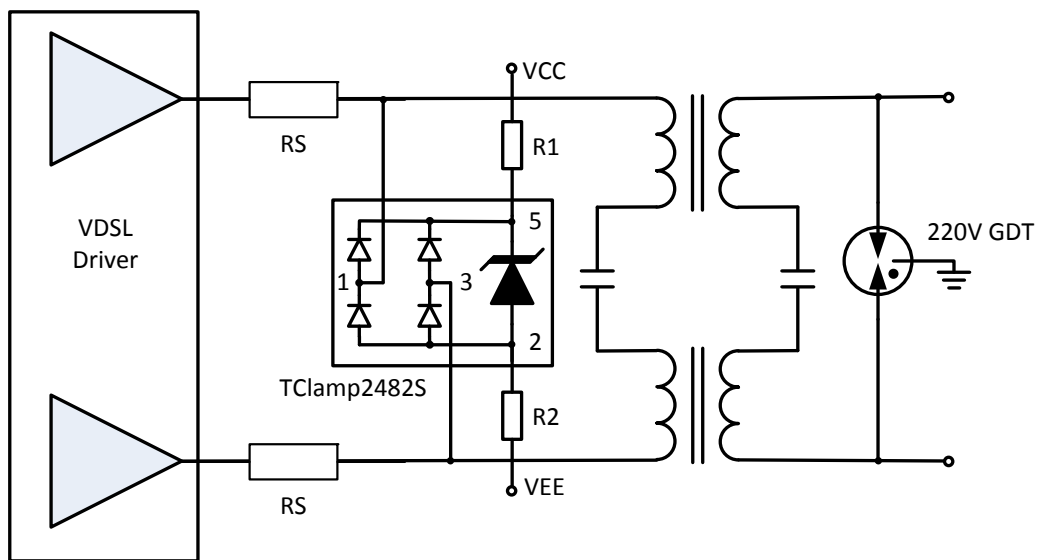

Figure 2 - Typical VDSL Class-H Protection Circuit

Applications Information

Device Connection and PCB Routing

The flow-through design of TClampxx82S simplifies board layout and PCB trace routing. The device can be configured for single ended applications such as G.Fast CPE (Figure 3) or dual voltage applications such as VDSL (Figure 4). Line 1A is connected at pin1 and its trace can continue under the part and connect to pin 6, which is not connected internally to the part. A similar connection can be made for Line 1B. This layout makes it easy to keep the differential signal traces symmetrical.

Bias

The device uses an internal bridge structure to effectively hide the capacitance of the TVS diode. However, in high voltage applications such as DSL, the initial signal will charge the capacitance of the TVS causing signal distortion and transmission errors. This distortion is only present until the TVS capacitance becomes charged and stabilizes. The solution is to pre-bias the TVS capacitance by connecting it to the external supply voltage (Figure 5). In the case of TClampxx82s, positive bias voltage should be connected at pin 5. For single ended applications, pin 2 is connected to ground (as shown in Figure 3). For dual voltage applications, pin 2 should be connected to negative polarity bias voltage. The bias resistors (R1, R2) should be large enough value as to minimize leakage current and minimize voltage drop over temperature (typically 100K Ohms to 1 Meg Ohm).

Surge and Power Induction Testing

DSL interfaces are wired telecom networks which are exposed to EOS from lightning surges and AC power line induction. DSL circuits are normally tested to the immunity requirements of ITU-T K.20, K.21, and K.44. TClampxx82S is designed to provide secondary protection to xDSL and G.Fast line drivers. They have been tested and passed the above requirements when used in conjunction with 220V gas discharge tubes (GDT). For more details, reference Semtech application note SI16-03 "Protecting G.Fast Circuits from Power Induction and Lightning Surges".

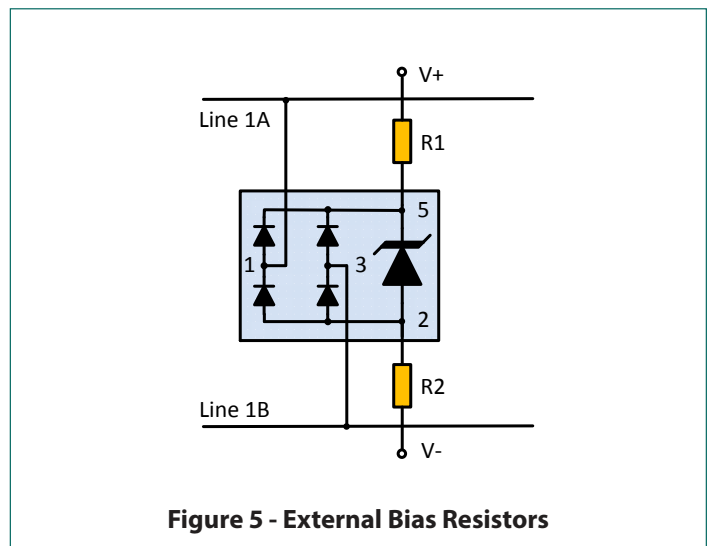
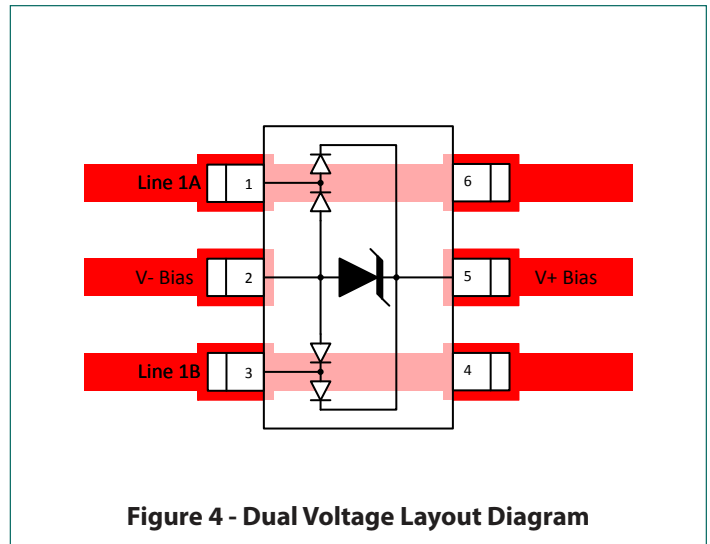
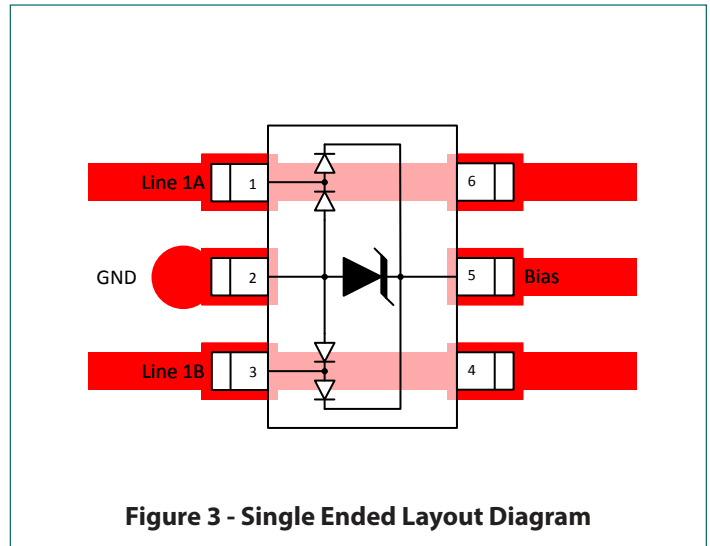

Outline Drawing - SOT-23 6L

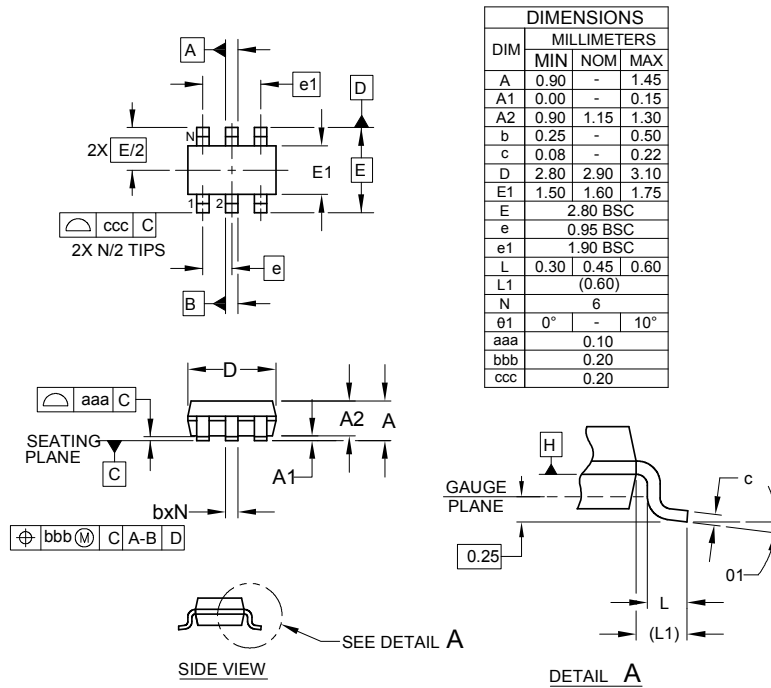

NOTES:

1. CONTROLLING DIMENSIONS ARE IN MILLIMETERS (ANGLES IN DEGREES).
2. DATUMS **-A-** AND **-B-** TO BE DETERMINED AT DATUM PLANE **-H-**
3. DIMENSIONS "E1" AND "D" DO NOT INCLUDE MOLD FLASH, PROTRUSIONS OR GATE BURRS.

Land Pattern - SOT-23 6L

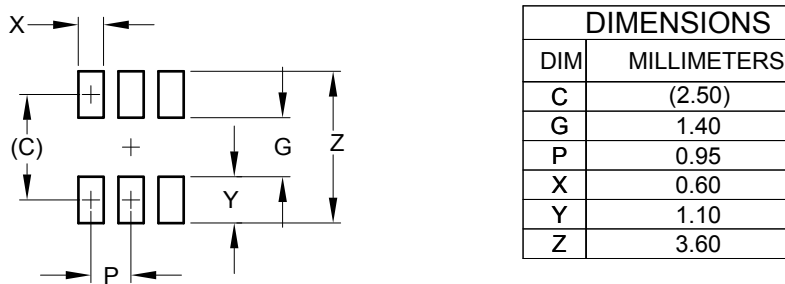

NOTES:

1. CONTROLLING DIMENSIONS ARE IN MILLIMETERS (ANGLES IN DEGREES).
2. THIS LAND PATTERN IS FOR REFERENCE PURPOSES ONLY. CONSULT YOUR MANUFACTURING GROUP TO ENSURE YOUR COMPANY'S MANUFACTURING GUIDELINES ARE MET.

Marking Example

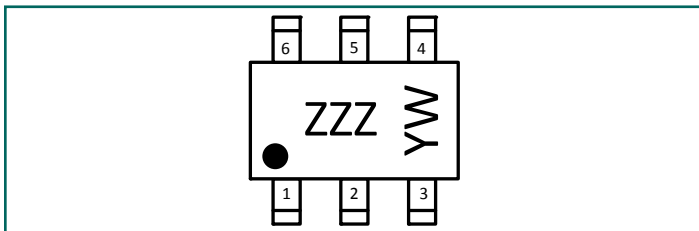

Notes:

ZZZ = Marking Code

YW = Alphanumeric character Date Code

See ordering information for part specific marking codes

Tape and Reel Specification

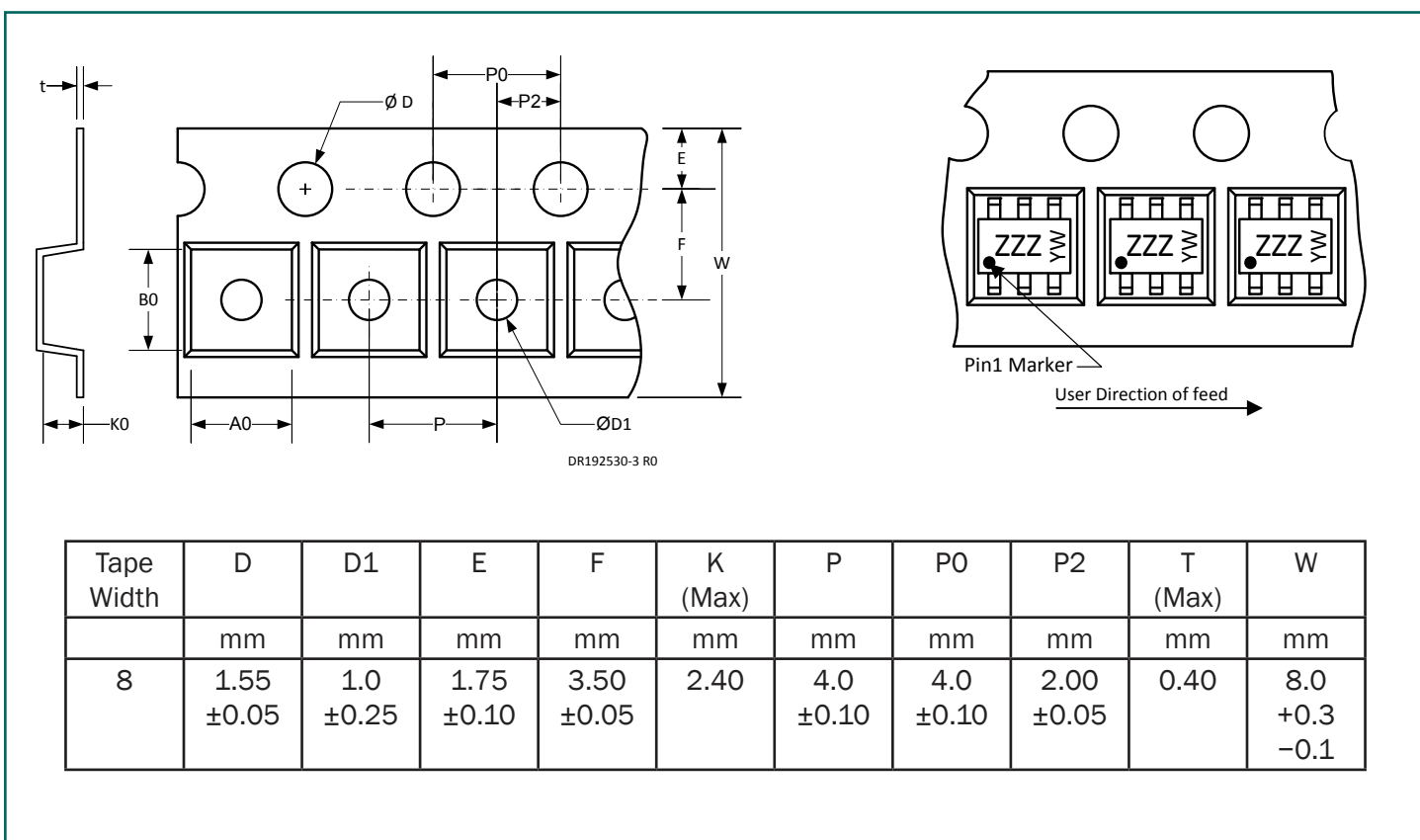

Ordering Information

Part Number	Working Voltage	Marking Code	Qty per 7 Inch Reel
TClamp0882S.TCT	8V	088	3000
TClamp1282S.TCT	12V	128	3000
TClamp2082S.TCT	20V	208	3000
TClamp2482S.TCT	24V	248	3000

TransClamp and TClamp are registered trademarks of Semtech Corporation.



IMPORTANT NOTICE

Information relating to this product and the application or design described herein is believed to be reliable, however such information is provided as a guide only and Semtech assumes no liability for any errors in this document, or for the application or design described herein. Semtech reserves the right to make changes to the product or this document at any time without notice. Buyers should obtain the latest relevant information before placing orders and should verify that such information is current and complete. Semtech warrants performance of its products to the specifications applicable at the time of sale, and all sales are made in accordance with Semtech's standard terms and conditions of sale.

SEMTECH PRODUCTS ARE NOT DESIGNED, INTENDED, AUTHORIZED OR WARRANTED TO BE SUITABLE FOR USE IN LIFE-SUPPORT APPLICATIONS, DEVICES OR SYSTEMS, OR IN NUCLEAR APPLICATIONS IN WHICH THE FAILURE COULD BE REASONABLY EXPECTED TO RESULT IN PERSONAL INJURY, LOSS OF LIFE OR SEVERE PROPERTY OR ENVIRONMENTAL DAMAGE. INCLUSION OF SEMTECH PRODUCTS IN SUCH APPLICATIONS IS UNDERSTOOD TO BE UNDERTAKEN SOLELY AT THE CUSTOMER'S OWN RISK. Should a customer purchase or use Semtech products for any such unauthorized application, the customer shall indemnify and hold Semtech and its officers, employees, subsidiaries, affiliates, and distributors harmless against all claims, costs damages and attorney fees which could arise.

The Semtech name and logo are registered trademarks of the Semtech Corporation. All other trademarks and trade names mentioned may be marks and names of Semtech or their respective companies. Semtech reserves the right to make changes to, or discontinue any products described in this document without further notice. Semtech makes no warranty, representation or guarantee, express or implied, regarding the suitability of its products for any particular purpose. All rights reserved.

© Semtech 2015

Contact Information

Semtech Corporation
200 Flynn Road, Camarillo, CA 93012
Phone: (805) 498-2111, Fax: (805) 498-3804
www.semtech.com