



MAX13042E Evaluation Kit

General Description

The MAX13042E evaluation kit (EV kit) demonstrates the MAX13042E 4-channel, bidirectional logic-level translator, featured in a tiny 12-bump UCSP™ package. The MAX13042E translates between V_L and V_{CC} logic levels and guarantees data rates up to 100Mbps.

As configured, the EV kit dedicates two channels for translation between V_L to V_{CC} and two channels for translation between V_{CC} to V_L . The EV kit gives the option of using SMA connectors or test points at the input signal lines, while providing scope probe jacks for monitoring the outputs. The V_L range is 1.62V to 3.2V and the ± 15 kV ESD-protected V_{CC} range is 2.2V to 3.6V.

Component List

DESIGNATION	QTY	DESCRIPTION
C1, C2	2	0.1 μ F $\pm 10\%$, 16V X7R ceramic capacitors (0402) Murata GRM155R71C104K TDK C1005X7R1C104K
C3	1	1 μ F $\pm 10\%$, 6.3V X5R ceramic capacitors (0402) Murata GRM155R60J105K TDK C1005X5R0J105K
IVL1, IVL2, IVCC3, IVCC4	4	SMA PCB vertical mounts
JU1	1	3-pin header
JU2–JU5	4	2-pin headers
OVCC1, OVCC2, OVL3, OVL4	4	5mm scope probe jacks
R1–R8	8	0 Ω resistors (0603)
R9–R12	4	49.9 Ω $\pm 1\%$ resistors (0402)
TP1–TP4	0	Not installed, test points
U1	1	4-channel, bidirectional logic-level translator (12-bump UCSP, 1.54mm x 2.12mm) Maxim MAX13042EEBC+ (Top Mark: ADQ)
—	5	Shunts
—	1	PCB: MAX13042E EV Kit+

UCSP is a trademark of Maxim Integrated Products, Inc.

Features

- ◆ Supply Voltage Ranges
1.62V to 3.2V (V_L)
2.2V to 3.6V (V_{CC})
- ◆ ± 15 kV ESD Protection on I/O V_{CC} Lines
- ◆ Two Dedicated Channels to Allow Translation from V_L to V_{CC}
- ◆ Two Dedicated Channels to Allow Translation from V_{CC} to V_L
- ◆ 100Mbps Guaranteed Data Rates
- ◆ Enable Input
- ◆ SMA Inputs and 5mm Scope Probe Jack Outputs
- ◆ 12-Bump UCSP (1.54mm x 2.12mm) Package
- ◆ Fully Assembled and Tested

Ordering Information

PART	TYPE
MAX13042EEVKIT+	EV Kit

+Denotes lead-free and RoHS-compliant.

Component Suppliers

SUPPLIER	PHONE	WEBSITE
Murata Mfg. Co., Ltd.	770-436-1300	www.murata.com
TDK Corp.	847-803-6100	www.component.tdk.com

Note: Indicate that you are using the MAX13042E when contacting these component suppliers.

Evaluates: MAX13042E

MAX13042E Evaluation Kit

Quick Start

Recommended Equipment

Before beginning, the following equipment is needed:

- 1.62V to 3.2V DC power supply
- 2.2V to 3.6V DC power supply
- Logic function generator
- Oscilloscope
- Standard 5mm scope probe

Procedure

The MAX13042E EV kit is fully assembled and tested. Follow the steps below to verify board operation. **Caution: Do not turn on the power supply until all connections are completed.**

- 1) Verify that a shunt is installed on jumper JU1 between pins 1-2 (normal operation).
- 2) Set the logic function generator to produce a 1MHz, 2V_{P-P}, 1V offset square wave. Disable the logic function generator output.
- 3) Connect the logic function generator to SMA input IVL1. Terminate function generator as necessary.
- 4) Connect the positive terminal of the 2V supply to the VL PCB pad and the ground terminal to the GND PCB pad.
- 5) Connect the positive terminal of the 3V supply to the VCC PCB pad and the ground terminal to the GND PCB pad.
- 6) Place an oscilloscope probe at scope jack output OVCC1.
- 7) Enable the power supplies and the logic function generator output.
- 8) Verify that OVCC1 shows a 1MHz, 3V_{P-P} square wave with a 1.5V offset.

Detailed Description

The MAX13042E EV kit demonstrates the MAX13042E 4-channel, bidirectional logic-level translator, featured in a tiny 12-bump UCSP package. The MAX13042E translates between V_L (1.62V to 3.2V) and V_{CC} (2.2V to 3.6V) logic levels and guarantees data rates up to 100Mbps. The MAX13042E also features ±15kV ESD protection on all I/O V_{CC} lines.

The MAX13042E EV kit circuit features I/O traces of matched length (within 5 mils) to maintain propagation-time uniformity. The EV kit dedicates two channels for translation between V_L to V_{CC} and two channels for translation between V_{CC} to V_L. Input signals can either be applied using SMA connectors IVL1, IVL2, IVCC3, and IVCC4 or at test points TP1–TP4. Output signals are monitored using oscilloscope probe jacks OVCC1, OVCC2, OVL3, and OVL4. The EV kit also utilizes the MAX13042E's enable function through configuration of jumper JU1.

Enable Input

Jumper JU1 controls the enable input of the MAX13042E. See Table 1 for JU1 jumper selection.

Table 1. Enable (EN) Pin Setting (Jumper JU1)

SHUNT POSITION	ENABLE PIN (EN)	EV KIT FUNCTION
1-2*	Connected to V _L	Enabled (normal operation)
2-3	Connected to GND	Disabled (tri-state operation)

*Default position.

SMA Inputs (IVL1, IVL2, IVCC3, and IVCC4)

To utilize the SMA connectors to apply input signals to the EV kit, these connections must be appropriately terminated. See Table 2 for SMA input termination settings. Signal traces will remain of matched length in this configuration.

Table 2. SMA Input Termination (Jumpers JU2–JU5)

SHUNT POSITION	INPUT TERMINATION
Installed	49.9Ω termination
Not installed*	None**

*Default position.

**Must configure signal generator for high-impedance output.

Test Point Input Option (TP1–TP4)

To implement use of the test point inputs, remove the appropriate resistor (R1, R2, R7, or R8) and apply a signal to the corresponding test point. Signal traces will remain of matched length in this configuration. GND pads are conveniently located on the EV kit to ground the input signal. **Note:** The input signal is not as well matched as it is with the SMA inputs.

MAX13042E Evaluation Kit

Evaluates: MAX13042E

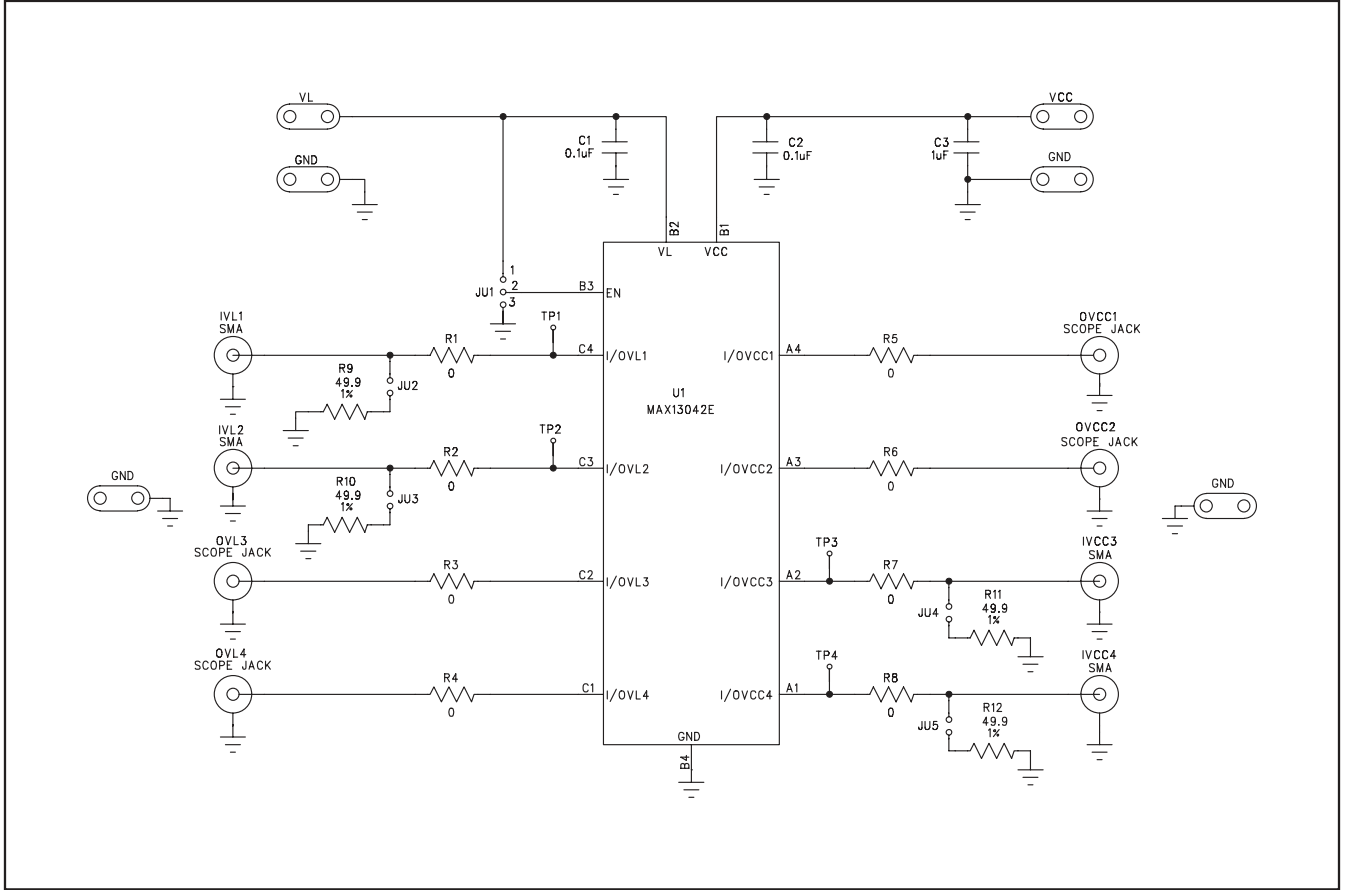

Figure 1. MAX13042E EV Kit Schematic

MAX13042E Evaluation Kit

Evaluates: MAX13042E

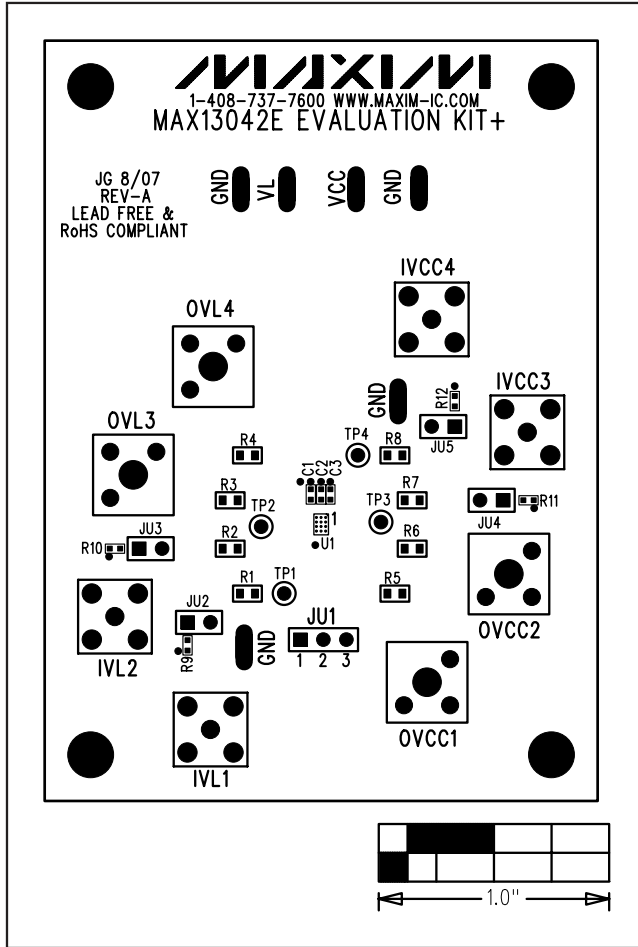

Figure 2. MAX13042E EV Kit Component Placement Guide—Component Side

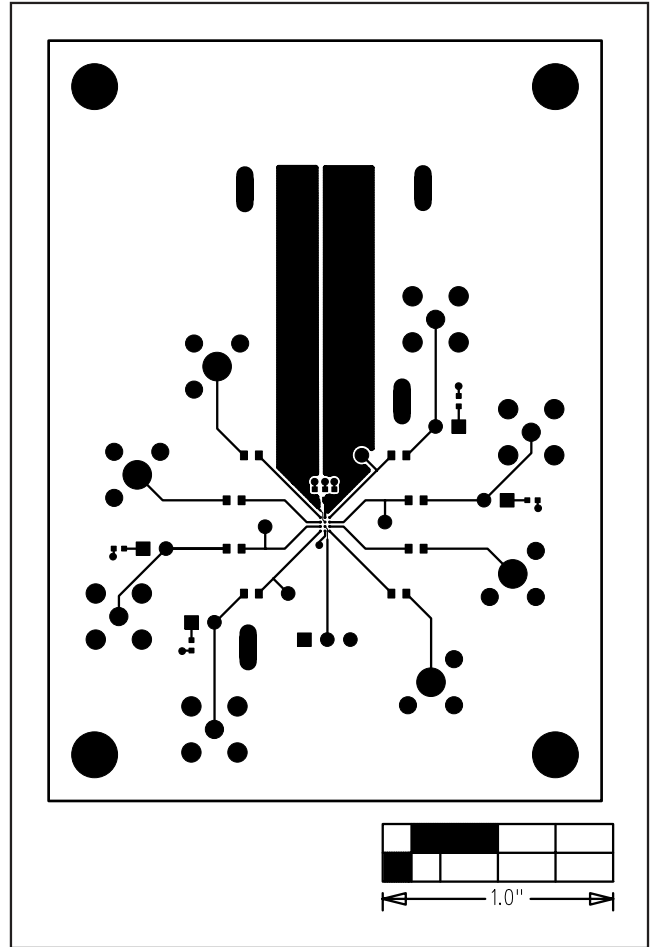

Figure 3. MAX13042E EV Kit PCB Layout—Component Side

MAX13042E Evaluation Kit

Evaluates: MAX13042E

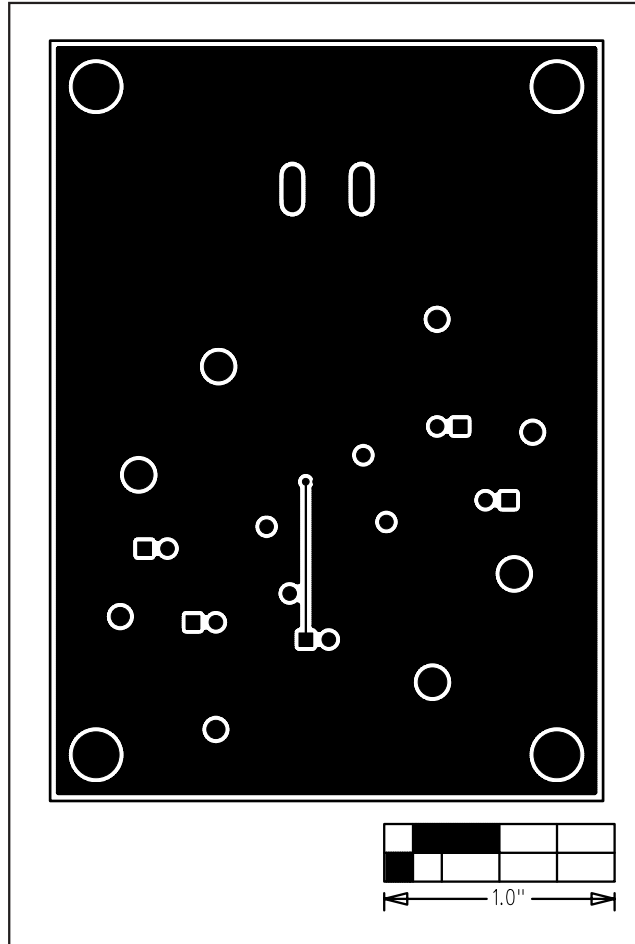

Figure 4. MAX13042E EV Kit PCB Layout—Solder Side

MAX13042E Evaluation Kit

Revision History

REVISION NUMBER	REVISION DATE	DESCRIPTION	PAGES CHANGED
0	10/07	Initial release	—
1	2/08	Corrected labeling on schematic.	3

Maxim cannot assume responsibility for use of any circuitry other than circuitry entirely embodied in a Maxim product. No circuit patent licenses are implied. Maxim reserves the right to change the circuitry and specifications without notice at any time.

6 **Maxim Integrated Products, 120 San Gabriel Drive, Sunnyvale, CA 94086 408-737-7600**