

THIS DRAWING IS UNPUBLISHED.	RELEASED FOR PUBLICATION	20	
COPYRIGHT © BY TYCO ELECTRONICS CORPORATION. ALL RIGHTS RESERVED.			
PART NUMBER	REVISION	DESCRIPTION	FEED TYPE
2150464-2	C	FINE CRIMP HEIGHT ADJUST	PNEUMATIC
7-2150464-2	C	PNEUMATIC AND CRIMP TOOLING KIT	PNEUMATIC
7-2150464-7	A	CRIMP TOOLING KIT	-

ATLANTIC VERSION TERMINATOR INTERFACE ADAPTER

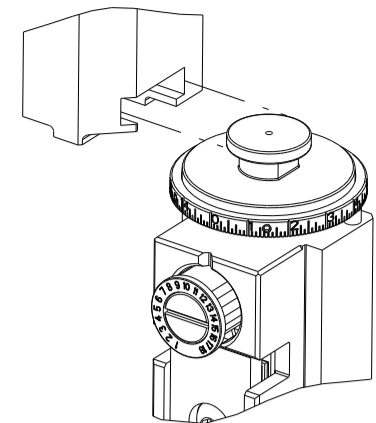

APPLICATOR DATA		
CRIMP	SIZE	TYPE
WIRE	2.79 mm [.110]	F
INSUL	4.57 mm [.180]	F
APPL INSTRUCTIONS 408-35043		

TERMINAL DATA: TE TERMINAL		TE CRIMP SPECIFICATION	
TERMINAL NAME: GROUNDING CLIP			
WIRE STRIP LENGTH		INSULATION DIAMETER RANGE	
5.16-5.92 mm [.203-.233 IN]		∅2.29-3.18 mm [.090-.125 IN]	
TERMINAL APPLICATION SPECIFICATION	114-13095	-	-
TERMINALS APPLIED			
TE TERMINAL	TE TERMINAL	TE TERMINAL	TE TERMINAL
63895-1	1217012-1	1217005-1	1742906-1

WIRE SIZE	CRIMP HEIGHT mm [INCH]	CRIMP HEIGHT REFERENCE SETTING
14 AWG	2.31+/-0.05 [.091+/- .002]	2.6
(2)18	2.16+/-0.05 [.085+/- .002]	5.4
16 AWG	2.11+/-0.05 [.083+/- .002]	5.7
18 AWG	1.91+/-0.05 [.075+/- .002]	8.7

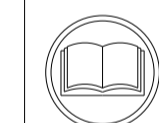

- 1 RECOMMENDED SPARE PARTS
- 2 REFER TO SUPPLIED INSTRUCTION SHEET FOR CLEANING, LUBRICATION AND STORAGE OF APPLICATOR.
- 3 APPLY PART NUMBER 1-23419-5 LOCTITE TO THREADS OF ITEM 180. APPLY PART NUMBER 2-23419-6 LOCTITE TO THREADS OF ITEM 242.
- 4 CRIMP HEIGHT REFERENCE SETTING WAS THE SETTING USED WHEN THE APPLICATOR WAS QUALIFIED AT THE FACTORY. ADJUSTMENT MAY BE NECESSARY WHEN RUNNING APPLICATOR IN THE FIELD.
- 5. UNLESS SPECIFIED OTHERWISE TORQUE VALUES SHALL BE USED PER DOCUMENT, 101-35000.
- 6 TERMINAL PITCH NOT COMPATIBLE WITH MECHANICAL FEED.
- 7 TERMINAL LUBRICANT IS RECOMMENDED.

***WARNING**
ON INSTALLATION, SET WIRE DISC TO CRIMP HEIGHT REFERENCE SETTING FOR LARGEST WIRE SIZE. CRIMP HEIGHT REFERENCE SETTINGS GREATER THAN THE VALUE SHOWN MAY CAUSE DAMAGE TO THE CRIMP TOOLING, REFER TO THE INSTRUCTION SHEET FOR PROPER SETUP AND ADJUSTMENTS.

LOC	DIST	REVISIONS					
A	66	P	LTN	DESCRIPTION	DATE	OWN	APVD
		A		RELEASE	17OCT2014	XZ	TE
		B		ECR-18-019463	13DEC2018	FL	CT
		C		ECR-21-007021	26JUL2021	FZ	TE

-	1	1	2119641-1	FEED CAM, AIR FEED	248	
-	1	1	2119082-4	CAM, SNAIL, INSULATION ADJUSTMENT	244	
-	1	1	2079764-1	WASHER, WAVE SPRING, CREST-TO-CREST	243	
3	-	1	1	2119083-1	RETAINER, INSULATION DIAL	242
-	1	1	2844940-3	AIR FEED MODULE	238	
-	1	1	1-18028-0	WASHER, FLAT, REG M8	192	
3	-	1	1	1-1752354-5	STANDOFF, HOLD-DOWN	180
-	1	1	6-993111-6	PIN, SLOTTED SPRING 3.0 X 14.0	177	
-	1	1	8-22280-7	SPRING, COMPRESSION	176	
-	1	1	1752353-2	GUIDE PIN, HOLDDOWN	175	
-	1	1	1901680-2	GUIDE PIN, HOLDDOWN	174	
-	REF	REF	994970-2	COUNTER, MAGNETIC	164	
7	-	1	1	2119955-2	ASSY, LUBRICATOR, END FEED	84
-	1	1	455888-5	SPACER, CRIMPER	82	
-	1	1	1803607-4	DOCUMENTATION PACKAGE	71	
-	2	2	2-18032-2	SCR, SET, FLT PNT, M3 X 10.0	70	
-	1	1	2119740-1	TAG, IDENTIFICATION	67	
-	2	2	2168078-1	SCREW, DRIVE, RH, RoHS, 2 x .188	66	
-	1	1	1901681-2	HOLDDOWN, TERMINAL	65	
-	1	1	2168083-2	SCR, SKT HD CAP, RoHS, M4 X 8.0	60	
-	1	1	5-18022-5	SCR, HEX HD CAP, M4 X 6.0	59	
-	4	4	2168400-8	SHCS, LOW HEAD, RoHS, M4 X 16	57	
-	2	2	2168083-3	SCR, SKT HD CAP, RoHS, M4 X 12.0	56	
-	2	2	5018030-1	NUT, HEX, REG, RoHS, M3	54	
-	2	2	986965-8	NUT, LOCK, HEX, TORQUE (M4)	53	
-	1	1	1-5018030-0	NUT, HEX, REG, RoHS, M3.5	52	
-	1	1	2063961-1	FEED FINGER	51	
-	1	1	18023-9	SCR, SKT HD CAP M4 X 6.0	49	
-	1	1	2119655-5	APPLICATOR BASIC ASSEMBLY, EF	46	
-	1	1	1803517-1	RAM ASSEMBLY, EF ATLANTIC	44	
-	1	1	1803602-1	SCR, BHSC, RoHS (M8 X 25)	41	
-	8	8	1-18028-2	WASHER, FLAT, REG M4	33	
-	2	2	2168083-9	SCR, SKT HD CAP, RoHS, M4 X 20	31	
-	2	2	2168083-2	SCR, SKT HD CAP, RoHS, M4 X 8.0	29	
-	1	1	690455-1	STRIPPER, FRONT CASTING	27	
-	2	2	1-2168083-5	SCR, SKT HD CAP, RoHS, M4 X 30	25	
-	1	1	1752371-5	PLATE, STRIP GUIDE	24	
-	2	2	2-22281-3	SPRING, COMPRESSION	22	
-	1	1	1803292-4	DRAG	20	
-	1	1	7-1901696-2	STRIP GUIDE, REAR	19	
-	1	1	7-1901695-2	STRIP GUIDE, FRONT	18	
-	4	4	1-2079383-1	SCR, BHSC, RoHS (M6 X 12)	17	
-	1	1	1752360-2	SPACER, HOLD-DOWN	13	
1	-	1	1	240644-1	PLATE, REAR SHEAR	11
-	-	-	-	-	10	
1	-	1	1	690482-7	PLATE, FRONT SHEAR	9
1	1	2	1	5-1803001-5	ANVIL, COMBINATION, END FEED	8
1	-	1	1	1-2217206-6	BLADE, SLUG	7
-	-	-	-	-	6	
-	1	1	1	4-240641-5	SPACER	5
-	1	1	1	238011-4	BLOCK, CRIMPER SPACER	4
1	1	2	1	2-1633961-7	CRIMPER, INSULATION F PREMIUM	3
-	1	1	1	455888-5	SPACER, CRIMPER	2
1	1	2	1	3-1633730-8	CRIMPER, WIRE	1
-	77	72	-2	PART NO	DESCRIPTION	ITEM NO

ATLANTIC VERSION
Shown on sheets 1 of 4 & 2 of 4
(Pacific version shown on sheets 3 of 4 & 4 of 4)

THIS DRAWING IS UNPUBLISHED. RELEASED FOR PUBLICATION. ALL RIGHTS RESERVED.		OWN	X. ZHAO	24JUL2014	TE Connectivity Harrisburg, PA 17105-3608
DIMENSIONS: mm		CHK	L. ZHANG	24JUL2014	
TOLERANCES UNLESS OTHERWISE SPECIFIED:		APVD	T. ELBIN	24JUL2014	NAME
0 PLC ±		PRODUCT SPEC		Ocean End Feed Applicator	
1 PLC ±		APPLICATION SPEC		-	
2 PLC ±		WEIGHT		-	
3 PLC ±		MATERIAL		-	
4 PLC ±		FINISH		-	
ANGLES		SCALE		1:1	
FINISH		SHEET		1 of 4	
-		REV		C	

LOC	DIST	REVISIONS			
P	LTN	DESCRIPTION	DATE	OWN	APVD
A	66	SEE SHEET 1			

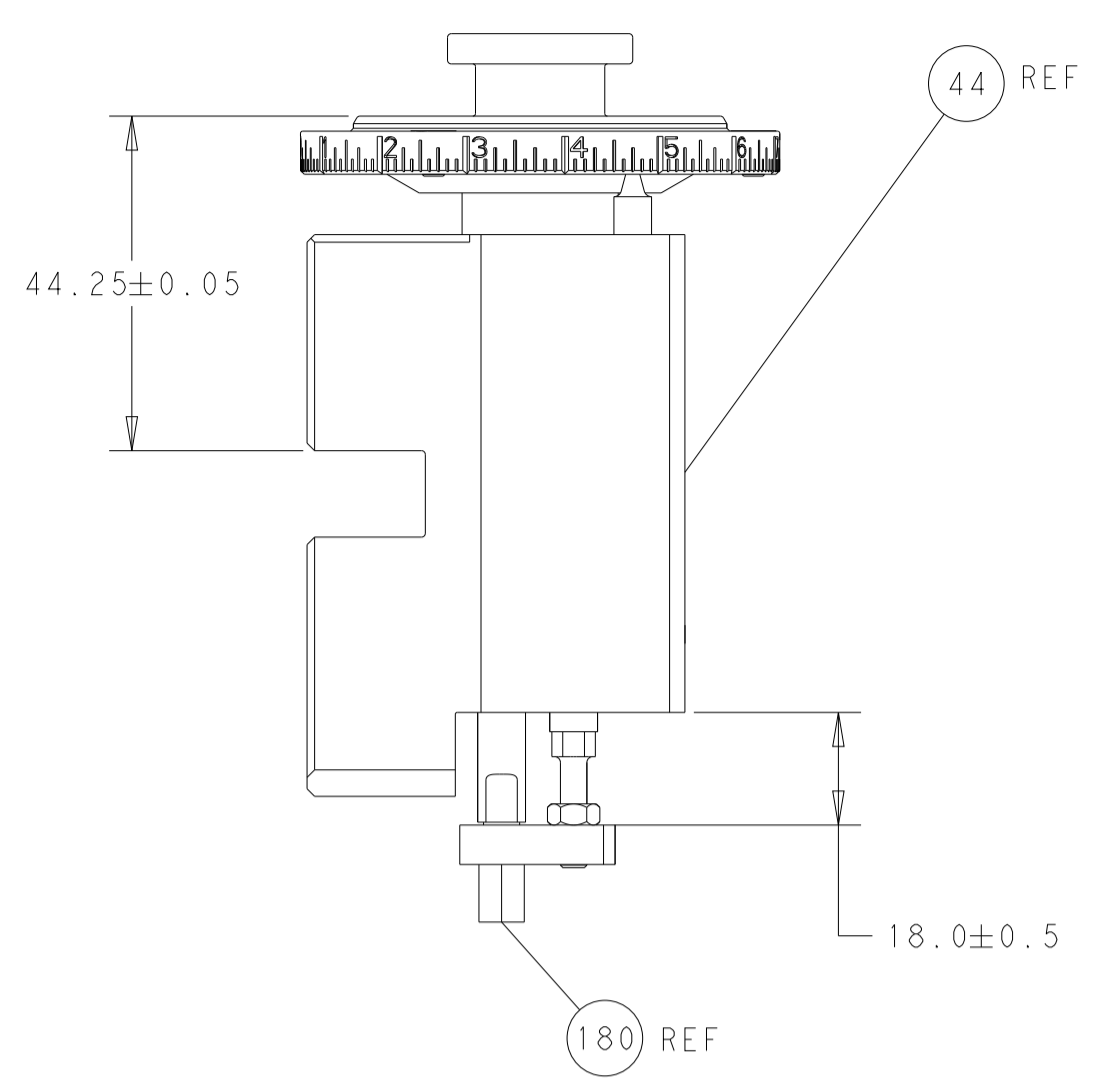

RAM AND HOLDDOWN SET-UP

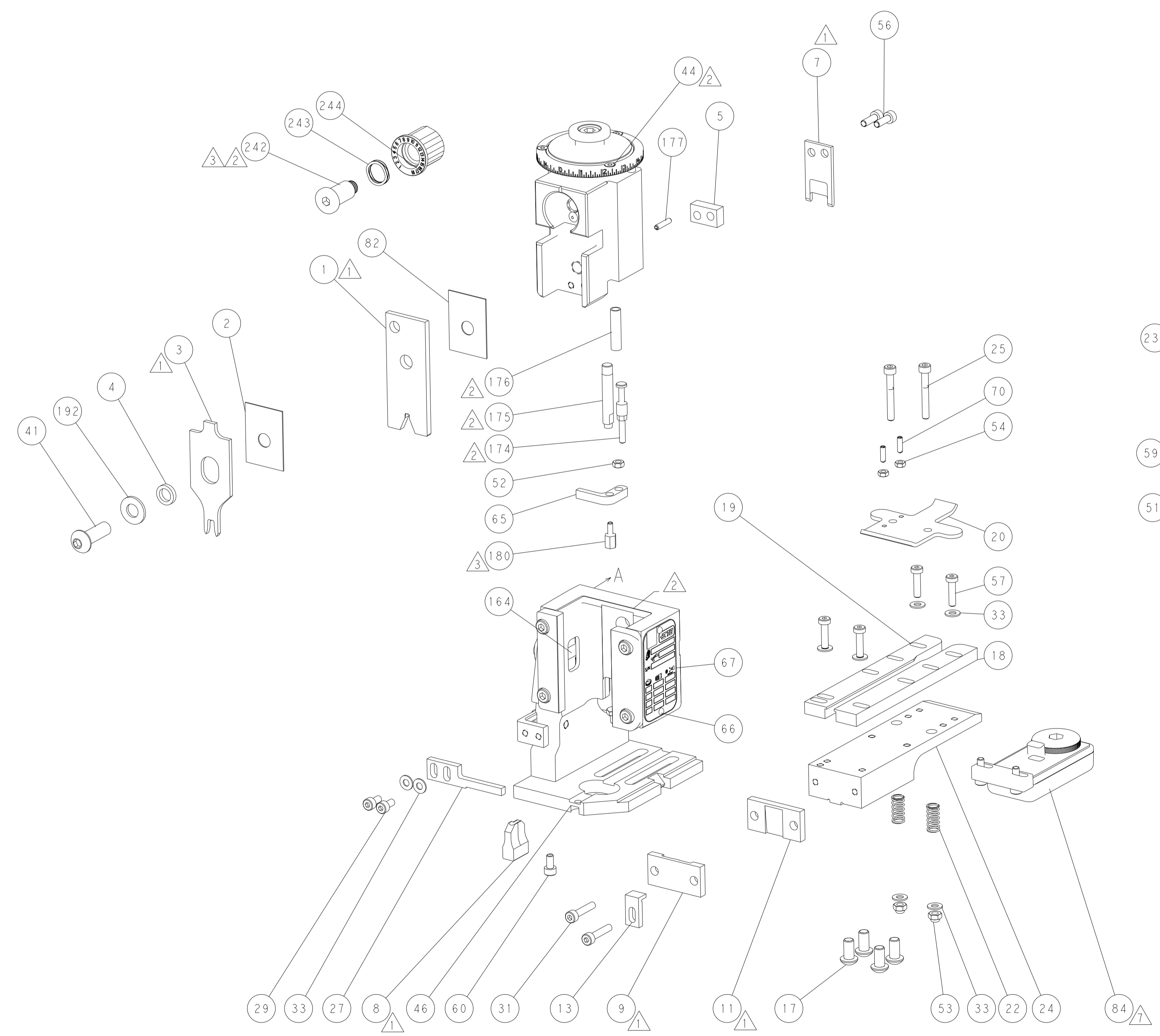

FEED TYPE

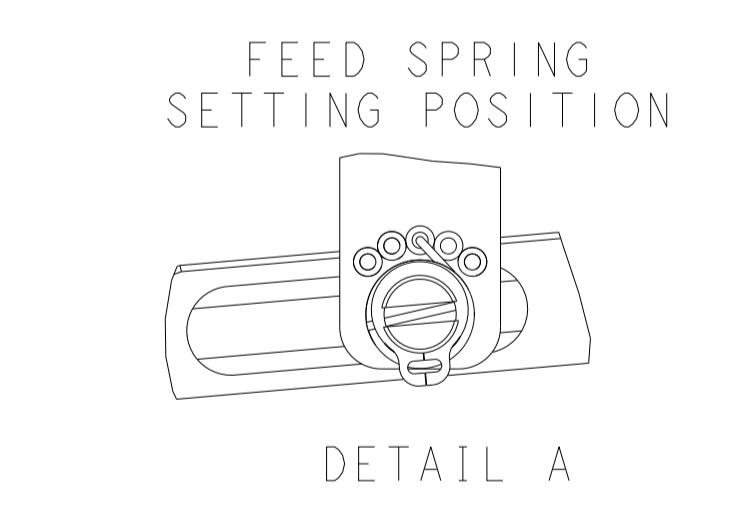
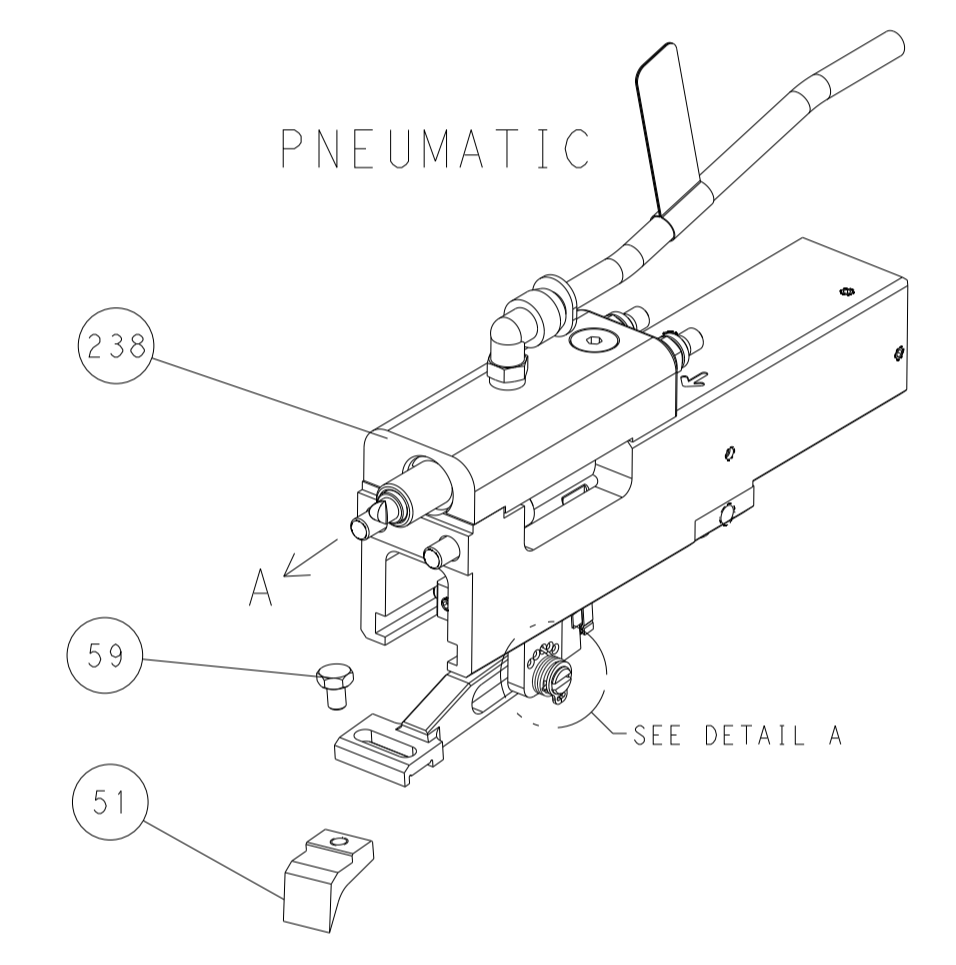

CAM POSITION

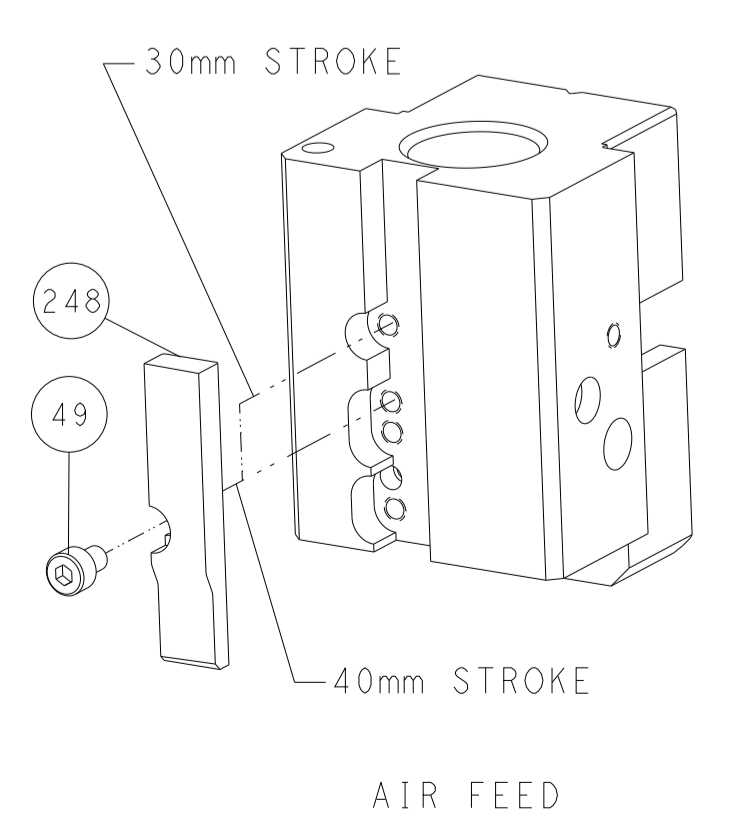

ATLANTIC VERSION
 Shown on sheets 1 of 4 & 2 of 4
 (Pacific version shown on sheets 3 of 4 & 4 of 4)

DIMENSIONS: mm 		TOLERANCES UNLESS OTHERWISE SPECIFIED: 0 PLC ± 1 PLC ± 2 PLC ± 3 PLC ± 4 PLC ± ANGLES ± MATERIAL - FINISH -		DWN X.ZHAO 24JUL2014 CHK L.ZHANG 24JUL2014 APVD T.ELBIN 24JUL2014 PRODUCT SPEC APPLICATION SPEC WEIGHT Customer Accessible Production Drawing		NAME Ocean End Feed Applier SIZE CAGE CODE DRAWING NO. A1 00779 C=2150464 SCALE 1:1 SHEET 2 OF 4 REV C		RESTRICTED TO TE Connectivity Harrisburg, PA 17105-3608	
-----------------------	--	---	--	---	--	--	--	---	--

PART NUMBER	REVISION	DESCRIPTION	FEED TYPE
2-2150464-2	C	FINE CRIMP HEIGHT ADJUST	PNEUMATIC
7-2150464-7	A	CRIMP TOOLING KIT	-

PACIFIC VERSION TERMINATOR
 INTERFACE ADAPTER

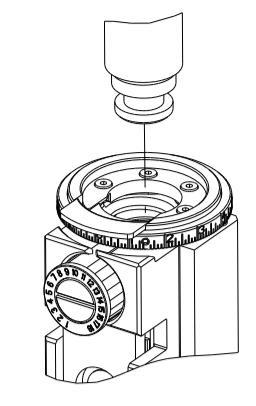

APPLICATOR DATA		
CRIMP	SIZE	TYPE
WIRE	2.79 mm (.110)	F
INSUL	4.57 mm (.180)	F
APPL INSTRUCTIONS 408-35043		

TERMINAL DATA: TE TERMINAL		TE CRIMP SPECIFICATION	
TERMINAL NAME: GROUNDING CLIP			
WIRE STRIP LENGTH 5.16-5.92 mm (.203-.233 IN)		INSULATION DIAMETER RANGE Ø2.29-3.18 mm (.090-.125 IN)	
TERMINAL APPLICATION SPECIFICATION 114-13095			
TERMINALS APPLIED			
TE TERMINAL 63895-1	TE TERMINAL 1217012-1	TE TERMINAL 1217005-1	TE TERMINAL 1742906-1

WIRE SIZE	CRIMP HEIGHT mm [INCH]	CRIMP HEIGHT REFERENCE SETTING
14 AWG	2.31+/-0.05 [.091+/-0.002]	2.6
(2)18	2.16+/-0.05 [.085+/-0.002]	5.4
16 AWG	2.11+/-0.05 [.083+/-0.002]	5.7
18 AWG	1.91+/-0.05 [.075+/-0.002]	8.7

- RECOMMENDED SPARE PARTS
- REFER TO SUPPLIED INSTRUCTION SHEET FOR CLEANING, LUBRICATION AND STORAGE OF APPLICATOR.
- APPLY PART NUMBER 1-23419-5 LOCTITE TO THREADS OF ITEM 180. APPLY PART NUMBER 2-23419-6 LOCTITE TO THREADS OF ITEM 242.
- CRIMP HEIGHT REFERENCE SETTING WAS THE SETTING USED WHEN THE APPLICATOR WAS QUALIFIED AT THE FACTORY. ADJUSTMENT MAY BE NECESSARY WHEN RUNNING APPLICATOR IN THE FIELD.
- UNLESS SPECIFIED OTHERWISE TORQUE VALUES SHALL BE USED PER DOCUMENT, 101-35000.
- TERMINAL PITCH NOT COMPATIBLE WITH MECHANICAL FEED.
- TERMINAL LUBRICANT IS RECOMMENDED.

***WARNING**
 ON INSTALLATION, SET WIRE DISC TO CRIMP HEIGHT REFERENCE SETTING FOR LARGEST WIRE SIZE. CRIMP HEIGHT REFERENCE SETTINGS GREATER THAN THE VALUE SHOWN MAY CAUSE DAMAGE TO THE CRIMP TOOLING, REFER TO THE INSTRUCTION SHEET FOR PROPER SETUP AND ADJUSTMENTS.

LOC	DIST	REVISIONS				
		P	LTN	DATE	OWN	APVD
A	66	-	-	SEE SHEET 1	-	-

-	1	2119082-4	CAM, SNAIL, INSULATION ADJUSTMENT	244
-	1	2079764-1	WASHER, WAVE SPRING, CREST-TO-CREST	243
-	1	2119083-1	RETAINER, INSULATION DIAL	242
-	1	2844940-3	AIR FEED MODULE	238
-	1	1-18028-0	WASHER, FLAT, REG M8	192
-	4	2079383-9	SCR, BHSC, RoHS (M6 X 20)	186
-	1	1-1752354-5	STANDOFF, HOLD-DOWN	180
-	1	6-993111-6	PIN, SLOTTED SPRING 3.0 X 14.0	177
-	1	8-22280-7	SPRING, COMPRESSION	176
-	1	1752353-2	GUIDE PIN, HOLDDOWN	175
-	1	1901680-2	GUIDE PIN, HOLDDOWN	174
-	REF	994970-2	COUNTER, MAGNETIC	164
-	1	2119641-2	FEED CAM, AIR FEED	152
-	1	2168083-8	SCR, SKT HD CAP, RoHS, M4 X 16	144
-	1	2119655-6	APPLICATOR BASIC ASSEMBLY, EF	141
-	1	1803518-1	RAM ASSEMBLY, EF PACIFIC	140
-	1	2119955-2	ASSY, LUBRICATOR, END FEED	84
-	1	455888-5	SPACER, CRIMPER	82
-	1	1803607-4	DOCUMENTATION PACKAGE	71
-	2	2-18032-2	SCR, SET, FLT PNT, M3 X 10.0	70
-	1	2119740-1	TAG, IDENTIFICATION	67
-	2	2168078-1	SCREW, DRIVE, RH, RoHS, 2 x .188	66
-	1	1901681-2	HOLDDOWN, TERMINAL	65
-	1	5-18022-5	SCR, HEX HD CAP, M4 X 6.0	59
-	4	2168400-8	SHCS, LOW HEAD, RoHS, M4 X 16	57
-	2	2168083-3	SCR, SKT HD CAP, RoHS, M4 X 12.0	56
-	2	5018030-1	NUT, HEX, REG, RoHS, M3	54
-	2	986965-8	NUT, LOCK, HEX, TORQUE (M4)	53
-	1	1-5018030-0	NUT, HEX, REG, RoHS, M3.5	52
-	1	2063961-1	FEED FINGER	51
-	1	18023-9	SCR, SKT HD CAP M4 X 6.0	49
-	1	1803602-1	SCR, BHSC, RoHS (M8 X 25)	41
-	8	1-18028-2	WASHER, FLAT, REG M4	33
-	2	2168083-9	SCR, SKT HD CAP, RoHS, M4 X 20	31
-	2	2168083-2	SCR, SKT HD CAP, RoHS, M4 X 8.0	29
-	1	690455-1	STRIPPER, FRONT CASTING	27
-	2	1-2168083-5	SCR, SKT HD CAP, RoHS, M4 X 30	25
-	1	1752371-5	PLATE, STRIP GUIDE	24
-	2	2-22281-3	SPRING, COMPRESSION	22
-	1	1803292-4	DRAG	20
-	1	7-1901696-2	STRIP GUIDE, REAR	19
-	1	7-1901695-2	STRIP GUIDE, FRONT	18
-	1	1752360-2	SPACER, HOLD-DOWN	13
-	1	240644-1	PLATE, REAR SHEAR	11
-	-	-	-	10
-	1	690482-7	PLATE, FRONT SHEAR	9
1	1	5-1803001-5	ANVIL, COMBINATION, END FEED	8
-	1	1-2217206-6	BLADE, SLUG	7
-	-	-	-	6
-	1	4-240641-5	SPACER	5
-	1	238011-4	BLOCK, CRIMPER SPACER	4
1	1	2-1633961-7	CRIMPER, INSULATION F PREMIUM	3
-	1	455888-5	SPACER, CRIMPER	2
1	1	3-1633730-8	CRIMPER, WIRE	1
-	77-22	PART NO	DESCRIPTION	ITEM NO

PACIFIC VERSION
 Shown on sheets 3 of 4 & 4 of 4
 (Atlantic version shown on sheets 1 of 4 & 2 of 4)

DIMENSIONS: mm 0 PLC ± 1 PLC ± 2 PLC ± 3 PLC ± 4 PLC ± ANGLES ± FINISH ±		TOLERANCES UNLESS OTHERWISE SPECIFIED: 0 PLC ± 1 PLC ± 2 PLC ± 3 PLC ± 4 PLC ± ANGLES ± FINISH ±		DWN X ZHAO 24JUL2014 CHK L ZHANG 24JUL2014 APVD T ELBIN 24JUL2014 PRODUCT SPEC APPLICATION SPEC WEIGHT SCALE 1:1 SHEET 3 OF 4 REV C		NAME Ocean End Feed Applicator SIZE CAGE CODE DRAWING NO RESTRICTED TO A1 00779 C=2150464 Customer Accessible Production Drawing	
---	--	---	--	---	--	---	--

LOC	DIST	REVISIONS			
P	LTN	DESCRIPTION	DATE	OWN	APVD
A	66	SEE SHEET 1	-	-	-

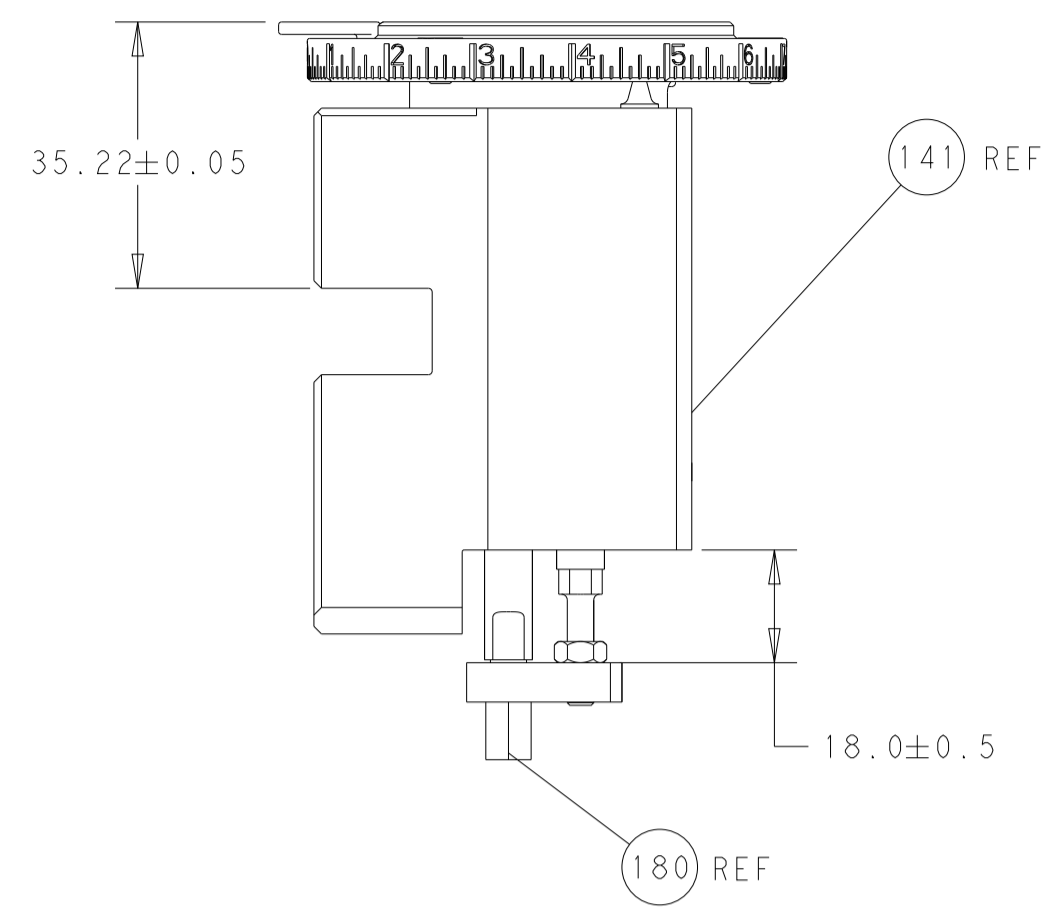

RAM AND HOLDDOWN SET-UP

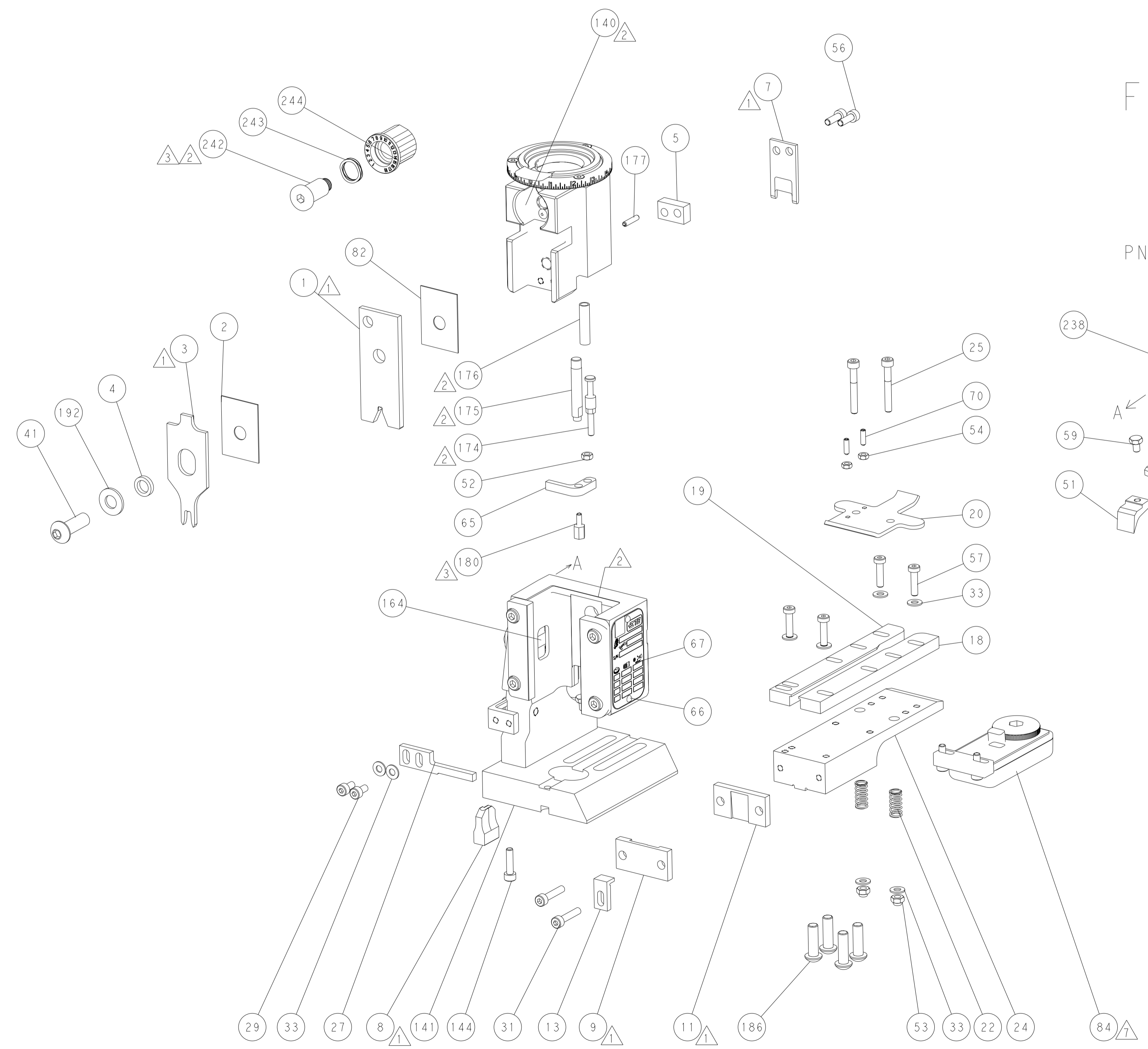

FEED TYPE

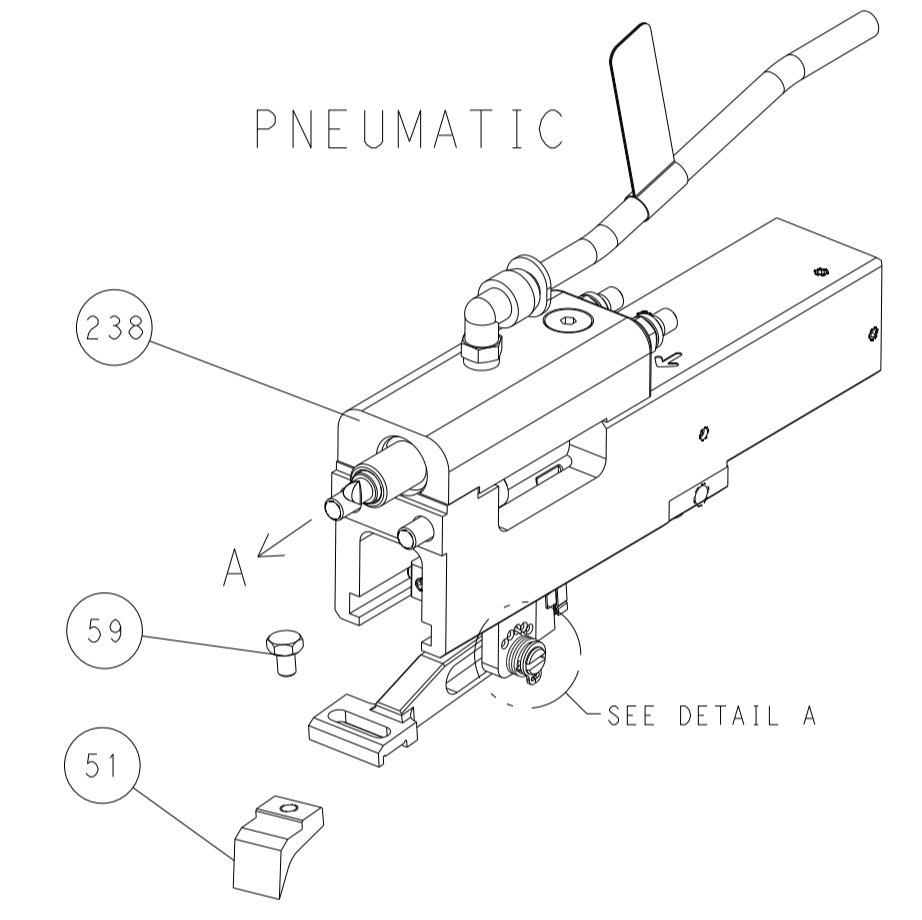

FEED SPRING SETTING POSITION

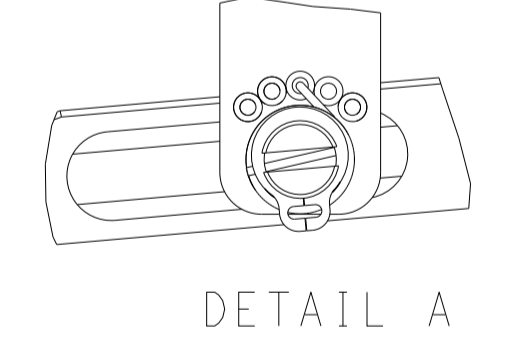

CAM POSITION

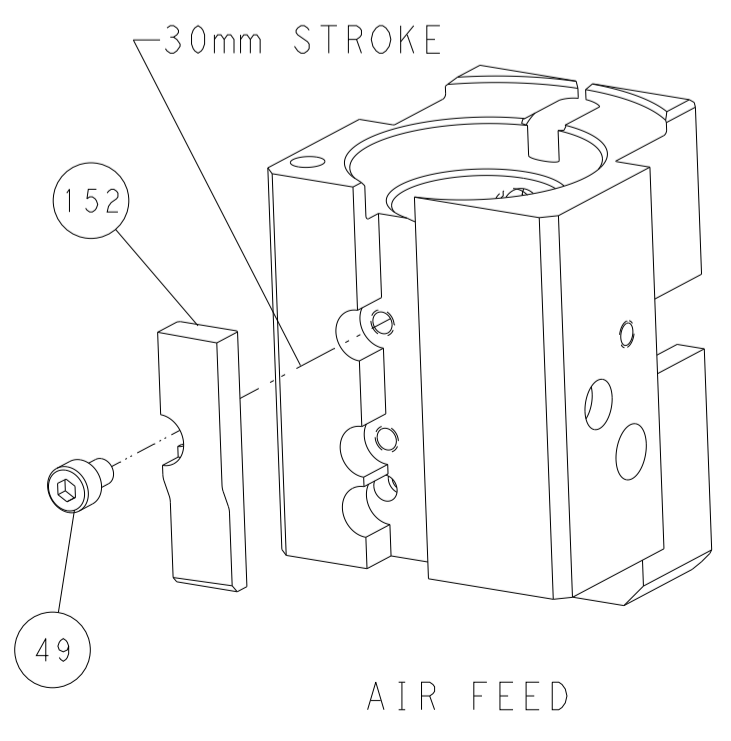

PACIFIC VERSION
 Shown on sheets 3 of 4 & 4 of 4
 (Atlantic version shown on sheets 1 of 4 & 2 of 4)

<small>THIS DRAWING IS UNPUBLISHED. RELEASED FOR PUBLICATION 20. COPYRIGHT 20 BY TYCO ELECTRONICS CORPORATION. ALL RIGHTS RESERVED.</small>		DWN X.ZHAO 24JUL2014 CHK L.ZHANG 24JUL2014 APVD T.ELBIN 24JUL2014	NAME Ocean End Feed Applier
DIMENSIONS: mm 	TOLERANCES UNLESS OTHERWISE SPECIFIED: 0 PLC ± 1 PLC ± 2 PLC ± 3 PLC ± 4 PLC ± ANGLES ± FINISH	SIZE CAGE CODE DRAWING NO A 00779 C=2150464	RESTRICTED TO -
MATERIAL:		WEIGHT:	SCALE 1:1 SHEET 4 OF 4 REV C