

**SPECIFICATION  
FOR  
LCD Module**

**Customer P/N:**

**Santek P/N: ST0430E3WY-RSLW-F**

**DOC. Revision: RS01**

**Customer Approval:**

--

	<b>SIGNATURE</b>	<b>DATE</b>
<b>PREPARED BY</b>	Aaron Lu	2018-08-09
<b>CHECKED BY</b>	Andy Song	2018-8-13
<b>APPROVED BY</b>	Natty Lee	2018-Aug-13

Document Revision History

Version	Revise Date	Description	Changed by
RS01	2018-08-09	First issue	Aaron Lu

Santek - CONFIDENTIAL

---

Table of Contents

1. GENERAL SPECIFICATION.....	4
2. BLOCK DIAGRAM .....	5
3. MECHANICAL DRAWING.....	6
4. INTERFACE ASSIGNMENT.....	7
5. ELECTRICAL SPECIFICATION.....	8
6. TOUCH PANEL SPECIFICATION.....	11
7. OPTICAL CHARACTERISTICS.....	16
8. RELIABILITY TESTS.....	21
9. INSPECTION CRITERION .....	22
10. PACKAGE DRAWING.....	25
11. PRECAUTIONS.....	26
12. LIMITED WARRANTY.....	26

Santek - CONFIDENTIAL

## 1. GENERAL SPECIFICATION

### 1.1. Description

The ST0430E3WY-RSLW-F is a color active matrix Thin Film Transistor (TFT) Liquid Crystal Display (LCD) that uses amorphous silicon (a-Si) TFT as a switching device. This model is composed of a single 4.3 inches transmissive type main TFT-LCD panel and touch panel. The resolution of the panel is 480(RGB) x 272 pixels and can display up to 16.7M color.

### 1.2. Feature

- TN type for main TFT-LCD panel
- Structure COG+FPC+BL+FRM+RTP

### 1.3. Application

- Display terminals for digital product

### 1.4. General Specification

No.	Item	Specification	Unit	Remark
1	LCD Size	4.3	inch	-
2	Panel Type	a-Si TFT active matrix	-	-
3	Resolution	480 x (RGB) x 272	pixel	-
4	Display Mode	Normally white, Transmissive	-	-
5	Display Number of Colors	16.7M	-	-
6	Viewing Direction	6 o'clock	-	Note
7	Contrast Ratio	500(Typ.)	-	-
8	Luminance	310(Typ.)	cd/m <sup>2</sup>	-
9	Module Size	105.4(W) x 67.1(H) x 4.38(T)	mm	Note
10	Active Area	95.04 (W) x 53.86(H)	mm	Note
11	Pixel Pitch	0.198 x 0.198	mm	-
12	Weight	TBD(Typ.)	g	-
13	Driver IC	HX8257-A	-	-
14	Light Source	10 LEDs White	-	-
15	Interface	RGB 24bit	-	-
16	Operating Temperature	-20~70	°C	-
17	Storage Temperature	-30~80	°C	-

Note: Please refer to the mechanical drawing.

**2.BLOCK DIAGRAM**

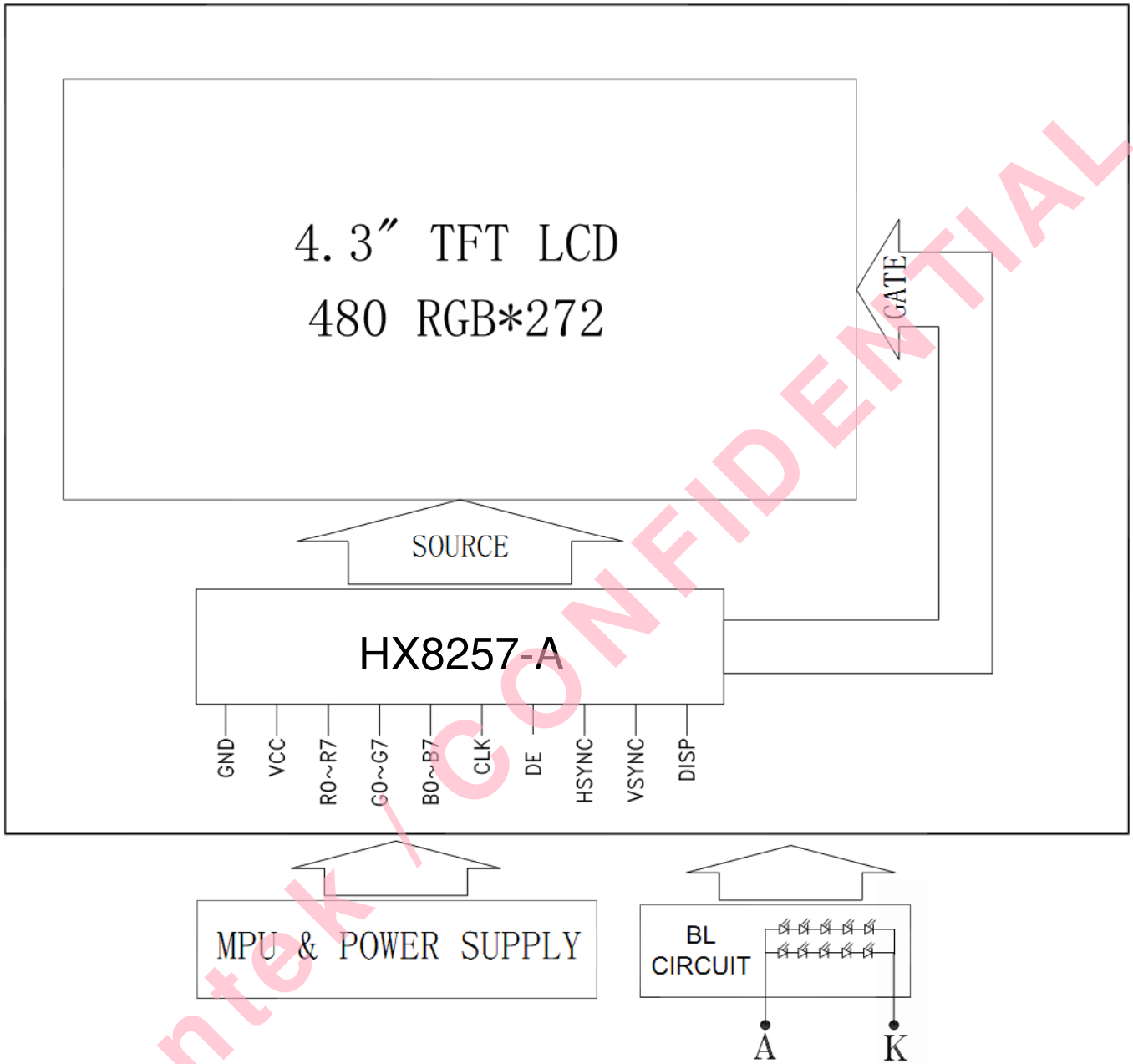

### 3. MECHANICAL DRAWING

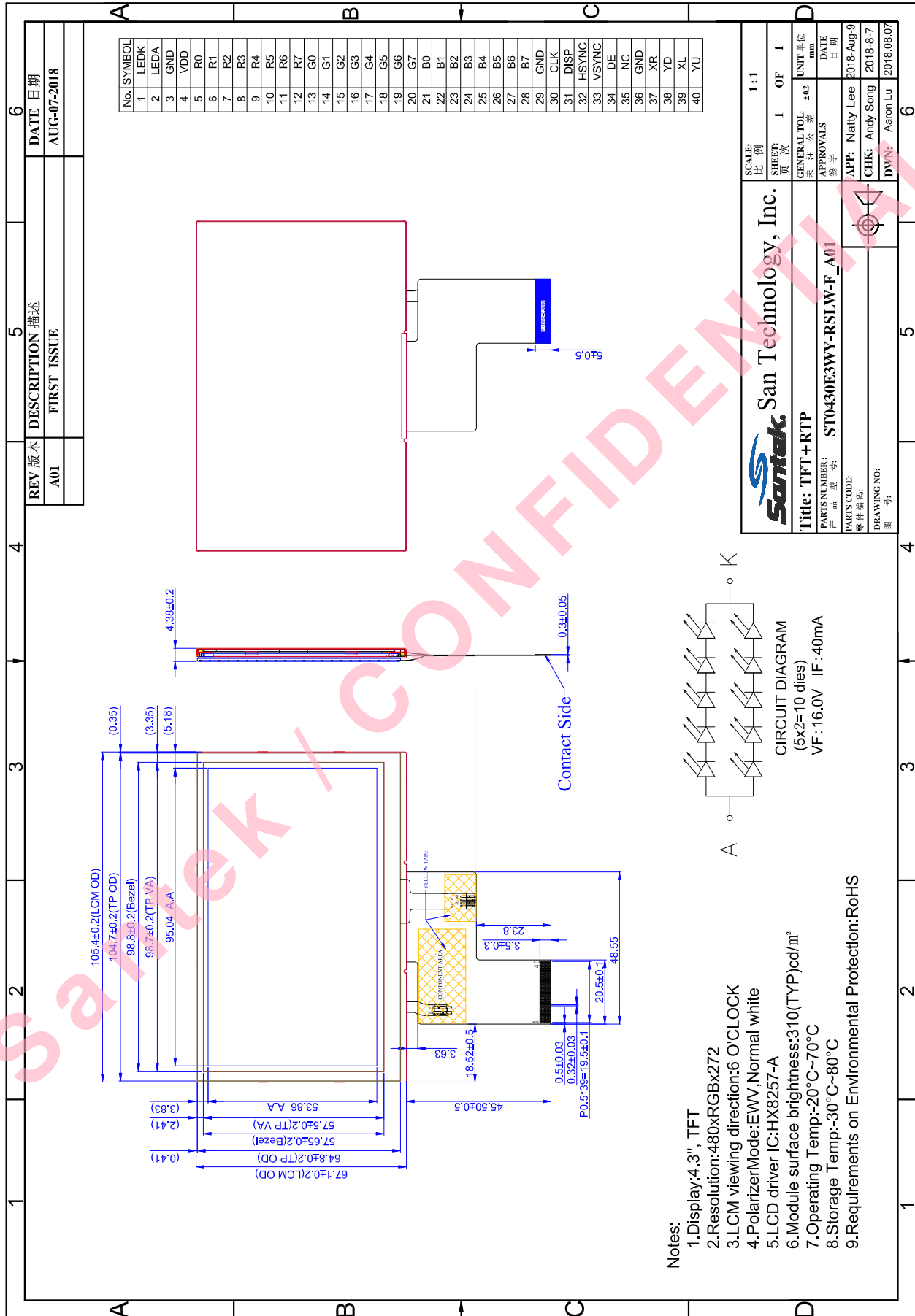

#### 4. INTERFACE ASSIGNMENT

PIN NO.	SYMBOL	I/O	FUNCTION DESCRIPTIONS
1	LEDK	P	Backlight Cathode
2	LEDA	P	Backlight Anode
3	GND	P	Ground
4	VDD	P	Digital Power
5	R0	I	Red data signal(LSB)
6	R1	I	Red data signal
7	R2	I	Red data signal
8	R3	I	Red data signal
9	R4	I	Red data signal
10	R5	I	Red data signal
11	R6	I	Red data signal
12	R7	I	Red data signal(MSB)
13	G0	I	Green data signal(LSB)
14	G1	I	Green data signal
15	G2	I	Green data signal
16	G3	I	Green data signal
17	G4	I	Green data signal
18	G5	I	Green data signal
19	G6	I	Green data signal
20	G7	I	Green data signal(MSB)
21	B0	I	Blue data signal(LSB)
22	B1	I	Blue data signal
23	B2	I	Blue data signal
24	B3	I	Blue data signal
25	B4	I	Blue data signal
26	B5	I	Blue data signal
27	B6	I	Blue data signal
28	B7	I	Blue data signal(MSB)
29	GND	I	Ground
30	CLK	I	Clock signal to sample each data
31	DISP	I	Display on/off signal (this pin is pulled high in internally)
32	HSYNC	I	Horizontal synchronizing signal
33	VSYNC	I	Vertical synchronizing signal
34	DE	I	Input data enable control. Internally pulled low.
35	NC	I	NC
36	GND	I	Ground
37	XR	I	Touch panel interface for XR
38	YD	I	Touch panel interface for YD
39	XL	I	Touch panel interface for XL
40	YU	I	Touch panel interface for YU

## 5. ELECTRICAL SPECIFICATION

### 5.1. APPLICATION CIRCUIT

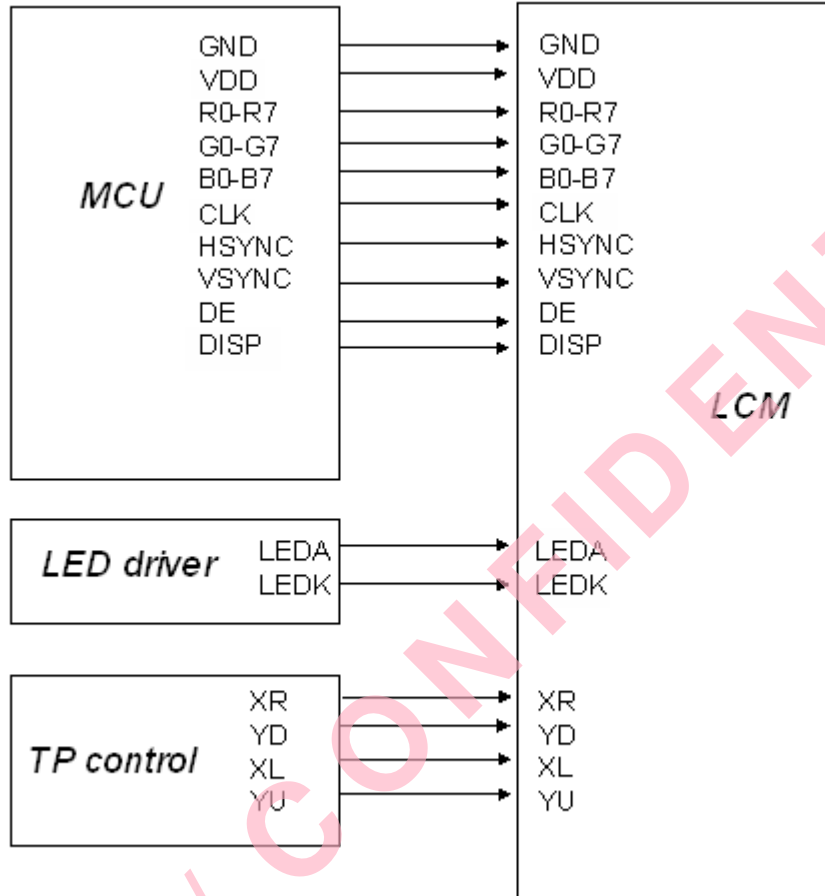

### 5.2. ABSOLUTE MAXIMUM RATINGS

ITEM	SYMBOL	CONDITION	STANDARD VALUE			UNIT
			MIN	TYP	MAX	
POWER SUPPLY FOR LOGIC	VDD	Ta=25°C	-0.3	-	+3.6	V
INPUT VOLTAGE	VCC	Ta=25°C	-0.3	-	+3.6	V
OPERATION TEMPERATURE	TOPR		-20		+70	°C
STORAGE TEMPERATURE	TSTG		-30		+80	°C



### 5.3. TYPICAL OPERATION CONDITION

#### 5.3.1. DC Characteristics

Item	Symbol	Condition	Min.	Typ.	Max.	Unit
POWER SUPPLY VOLTAGE	VDD-GND	Ta= +25°C	-	3.3	-	V
INPUT VOLTAGE "H" LEVEL	VIH	-	0.8VDD	-	VDD	V
INPUT VOLTAGE "L" LEVEL	VIL	-	GND	-	0.2VDD	V
OUTPUT VOLTAGE "H" LEVEL	VOH	IOH=200uA	VDD-0.3	-	VDD	V
OUTPUT VOLTAGE "L" LEVEL	VOL	IOL=200uA	GND	-	GND+0.3	V

#### 5.3.2. AC Characteristics

(480RGBx272, T<sub>A</sub>=25°C, VDDIO=1.8V to 3.6V, DVSS= 0V)

Parameter	Symbol	Spec.			Unit
		Min.	Typ.	Max.	
Clock cycle	f <sub>CLK</sub> <sup>(1)</sup>	-	9	15	MHz
Hsync cycle	1/th	-	17.14	-	KHz
Vsync cycle	1/tv	-	59.94	-	Hz
Horizontal signal					
Horizontal cycle	th	525	525	605	CLK
Horizontal display period	thd	480	480	480	CLK
Horizontal front porch	thf	2	2	82	CLK
Horizontal pulse width	thp <sup>(2)</sup>	2	41	41	CLK
Horizontal back porch	thb <sup>(2)</sup>	2	2	41	CLK
Vertical signal					
Vertical cycle	tv	285	286	399	H <sup>(1)</sup>
Vertical display period	tvd	272	272	272	H <sup>(1)</sup>
Vertical front porch	tvf	1	2	227	H <sup>(1)</sup>
Vertical pulse width	tvp <sup>(2)</sup>	1	10	11	H <sup>(1)</sup>
Vertical back porch	tvb <sup>(2)</sup>	1	2	11	H <sup>(1)</sup>

**Note:** (1) Unit: CLK=1/ f<sub>CLK</sub>, H= th,

(2) It is necessary to keep tvp+tvb=12 and thp+thb=43 in sync mode. DE mode is unnecessary to keep it.

5.4. INTERFACE TIMING CHARACTERISTICS

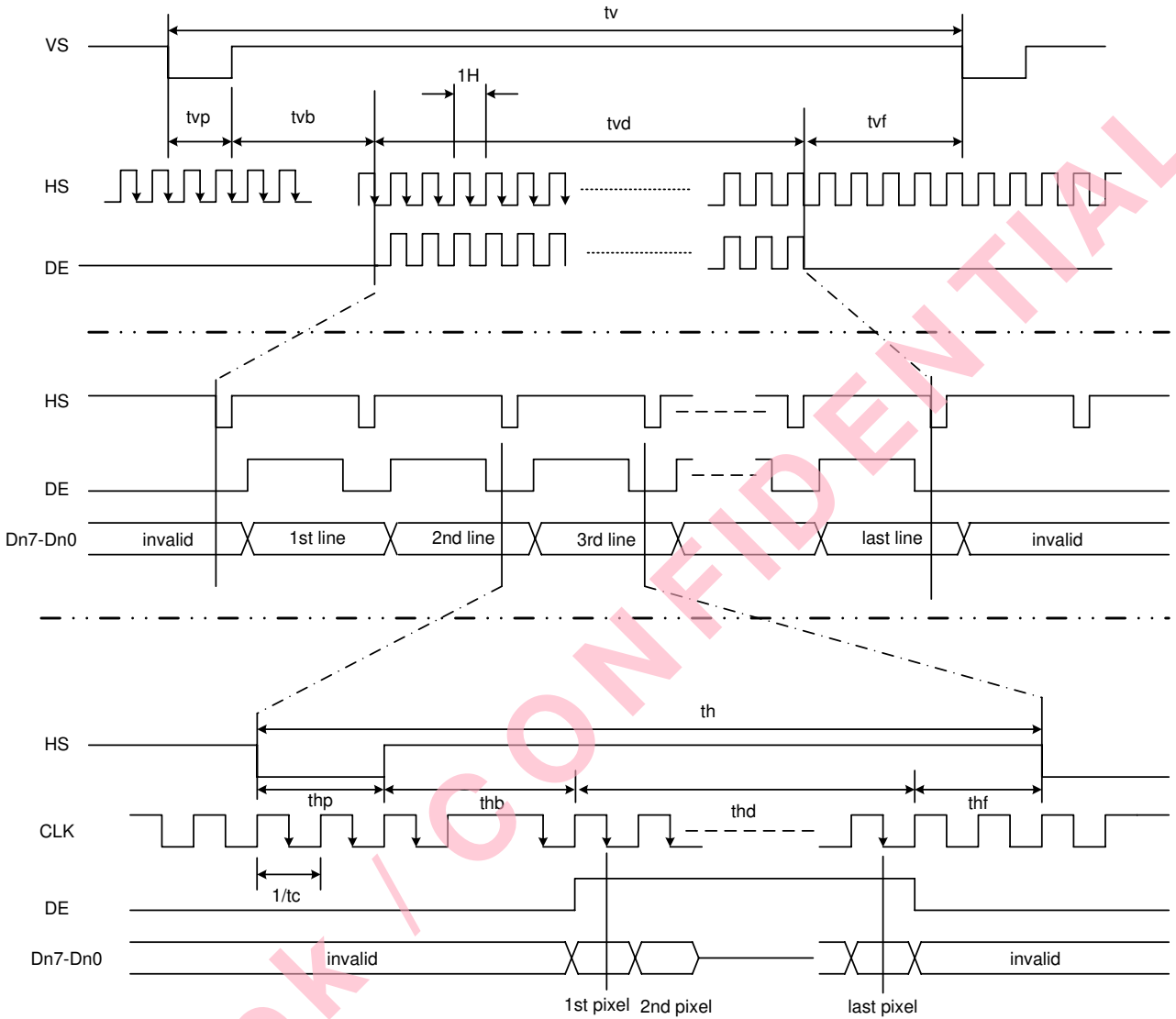

Parallel RGB Input Timing

### 5.6. POWER ON/OFF SEQUENCE

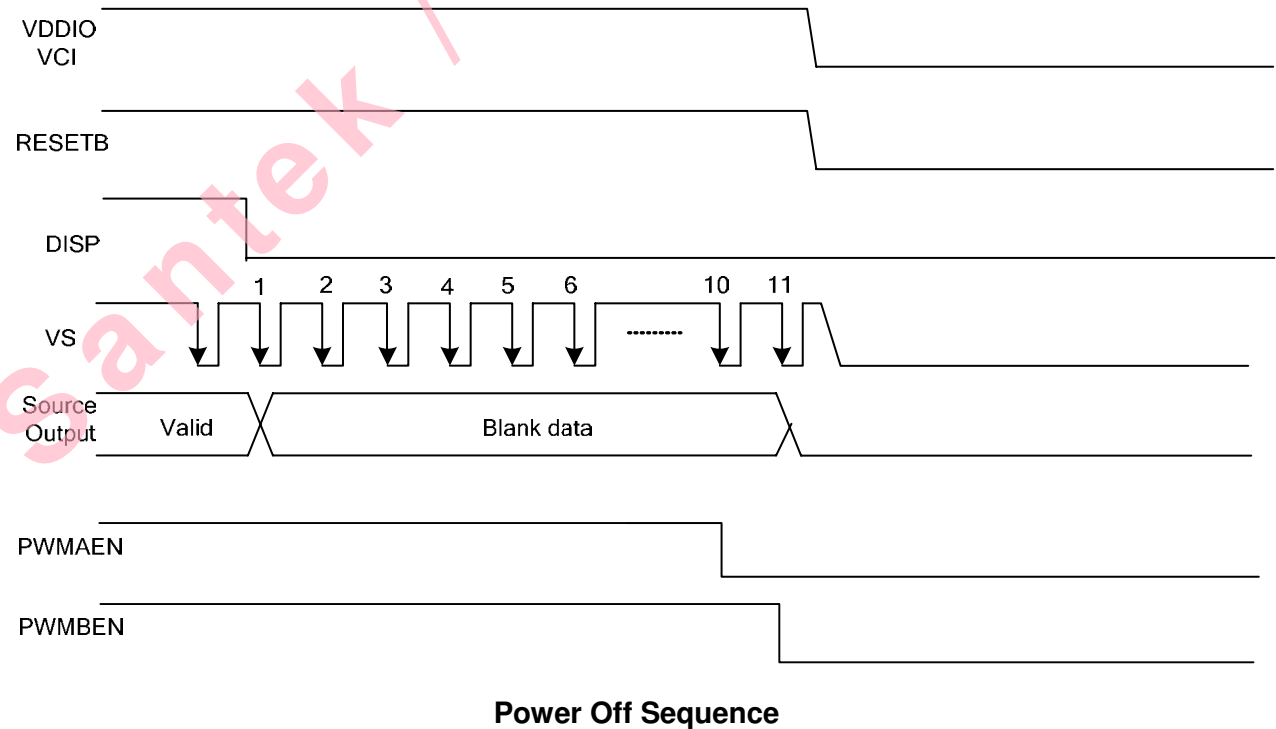
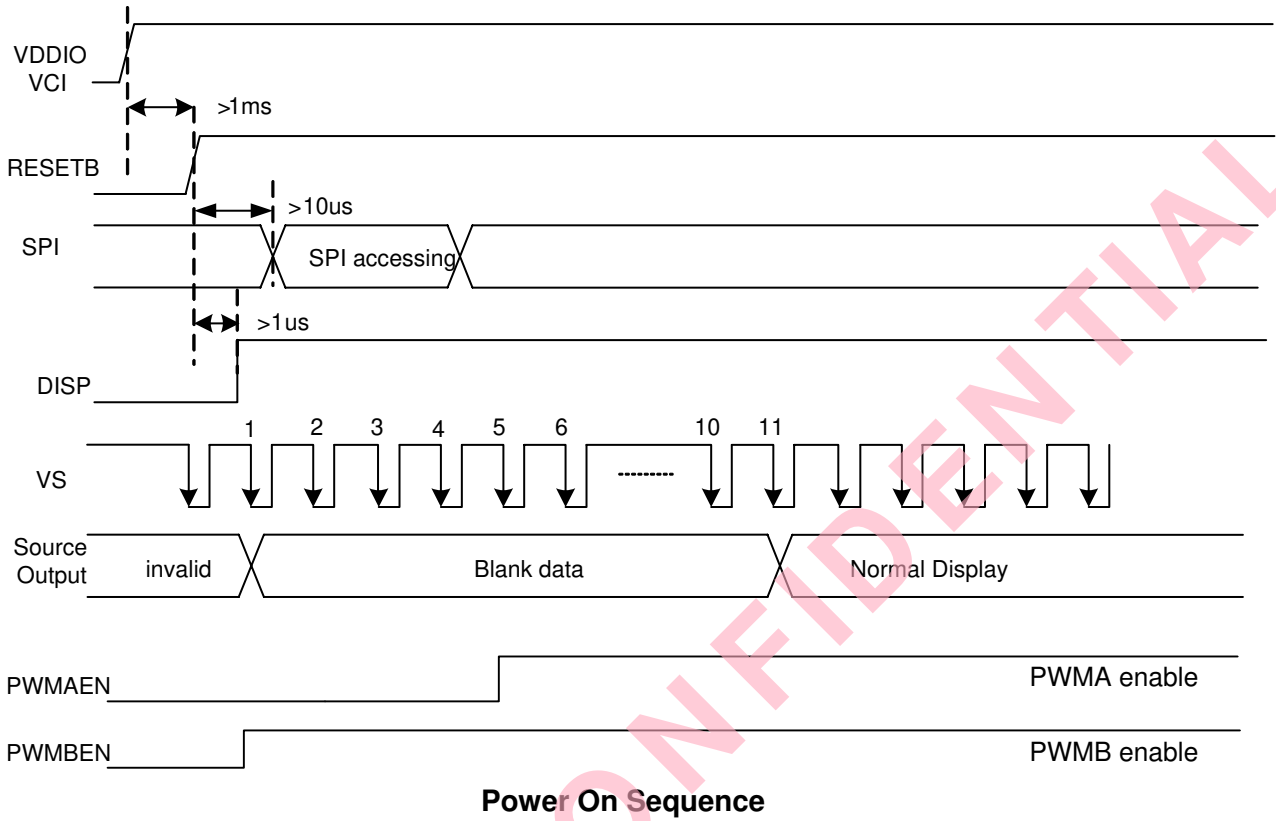

## 5.7. BACKLIGHT SPECIFICATION

### 5.7.1. Backlight Circuit

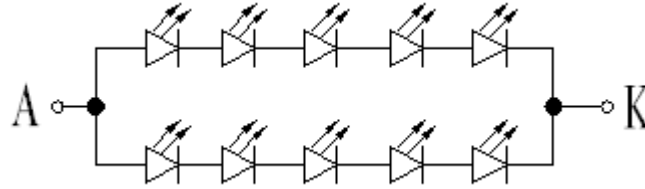

### 5.7.2. Absolute Ratings

PARAMETER	SYMBOL	SPECIFICATIONS	UNIT
POWER DISSIPATION	$P_D$	640	mW
FORWARD CURRENT (Single Chip)	$I_{Fm}$	20	mA
REVERSE VOLTAGE (Single Chip)	$V_R$	5	V

### 5.7.3. Electrical Characteristics

( $T=25^{\circ}C$ )

PARAMETER	SYMBOL	CONDITION	STANDARD VALUE			UNIT
			MIN	TYP	MAX	
FORWARD VOLTAGE	$V_F$	$I_F = 40mA$	15	16	17	V
OPERATING LED LIFE TIME (Single Chip)	Hr	$I_F = 20mA$	-	20,000	-	Hour

Note (1) LED life time (Hr) can be defined as the time in which it continues to operate under the condition:  $T_a = 25 \pm 3^{\circ}C$ , typical IL value indicated in the above table until the brightness becomes less than 50%.

## 6. TOUCH PANEL SPECIFICATION

### 6.1. ELECTRICAL CHARACTERISTICS

Item	Value			Unit	Remark
	Min.	Typ.	Max.		
Linearity	-1.5	-	+1.5	%	After environment and life test
Terminal Resistance	200	-	1000	Ω	X(Film side)
	200	-	800	Ω	Y(Glass side)
Insulation Resistance	20	-	-	MΩ	DC 25V 1min
Operating Voltage	-	-	7	V	DC

### 6.2. OPTICAL CHARACTERISTICS

Item	Value			Unit	Remark
	Min.	Typ.	Max.		
Response Time	-	-	10	ms	-
Light Transparency	76	-	-	%	-
Haze	6	-	12	%	-

### 6.3. MECHANICAL CHARACTERISTICS

Item	Value			Unit	Remark
	Min.	Typ.	Max.		
Active Force	70	-	120	g	Note 1
Surface Hardness	3	-	-	H	-
Pen Sliding Durability	100,000	-	-	time	Note 2
Hitting Durability	1,000,000	-	-	time	Note 3

Note 1: Do not operate it with a stylus other than a polyacetal pen (tip R0.8mm or less) or a finger, especially those with hard or sharp tips such as a ball point pen or a mechanical pencil.

Note 2: Test Condition:

End shape: R0.8mm and R8.0mm,

Resistance between X and Y axis must be equal or lower than 2KΩ, the test voltage =DC5V.

Note 3: Measurement For Linearity. (After environment and life test)

-Load: 150g with End shape R0.8 mm Polyacetal resin.

-Measuring area: 1.0mm inside the edge of touch panel active area, pitch 5mm. (Fig. 1)

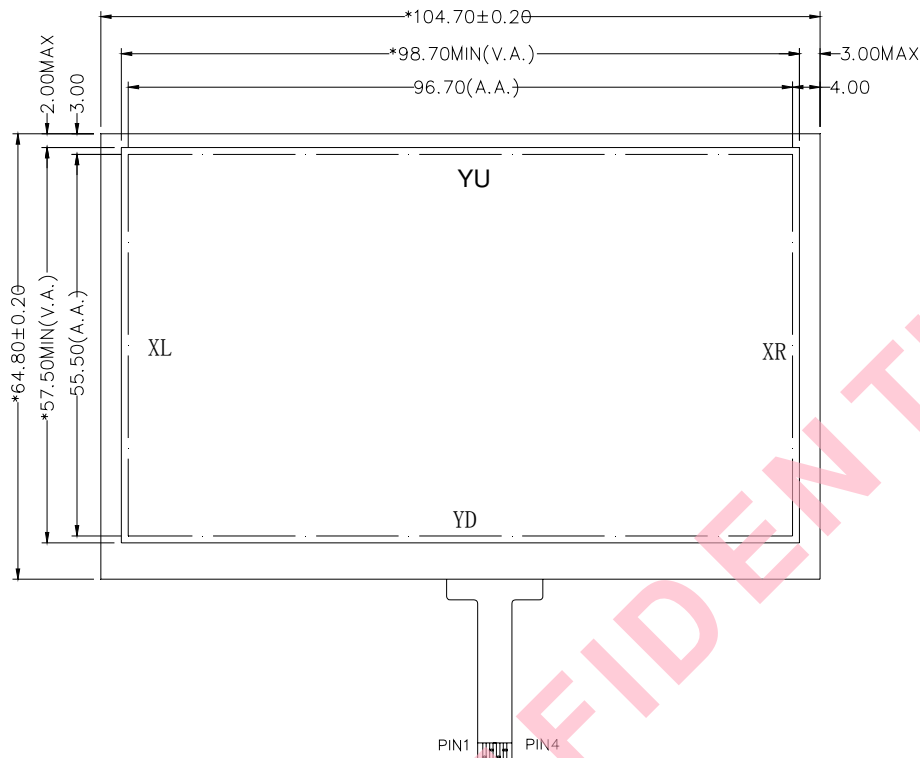

Fig. 1 Measuring area for Linearity

Note 4: Measurement for surface area.

- Scratch 100,000 times of straight line on the screen with a stylus which is changed every 20,000 times. One time is defined in one direction, strike one time, and then in the reverse direction strike one time that defined 2nd time.
- Force: 150gf.
- Speed: 150mm/sec.
- Writing Length: 25mm.
- Stylus: R0.8 polyacetal tip.
- Measuring area: 2.0mm inside the edge of touch panel active area, any line. (Fig. 2)
- Result: the SPEC of Electrical Characteristics pass.

Note 5: Hit 1,000,000 times on the screen with a R0.8mm Polyacetal resin By stylus tapping at same points.

- Force: 250gf.
- Speed: 5times/sec.
- Measuring area: 2.0mm inside the edge of touch panel active area, any point. (Fig. 2)
- Result: The SPEC of Electrical Characteristics pass.

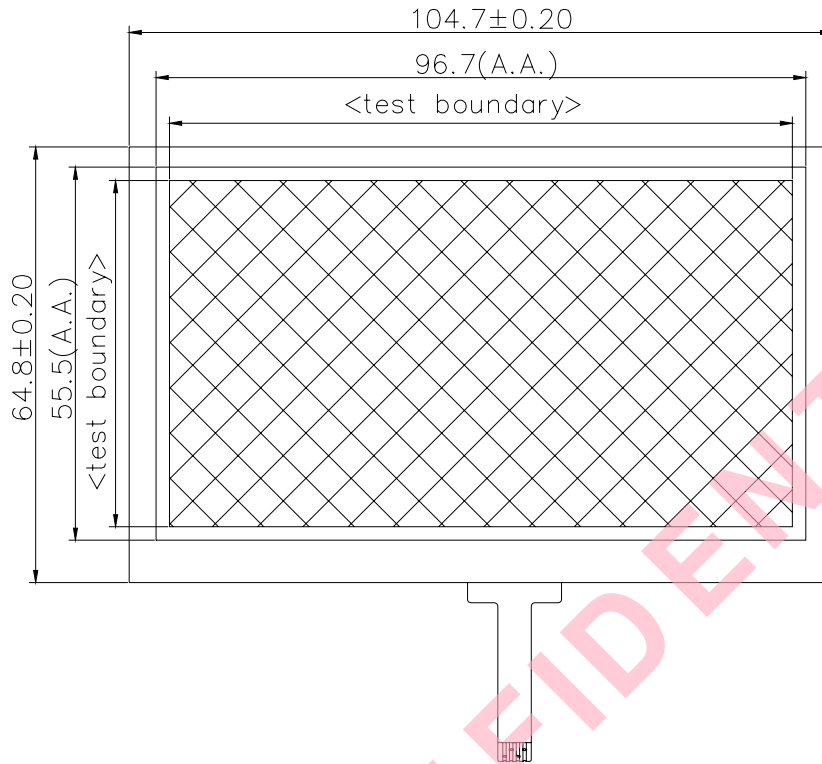
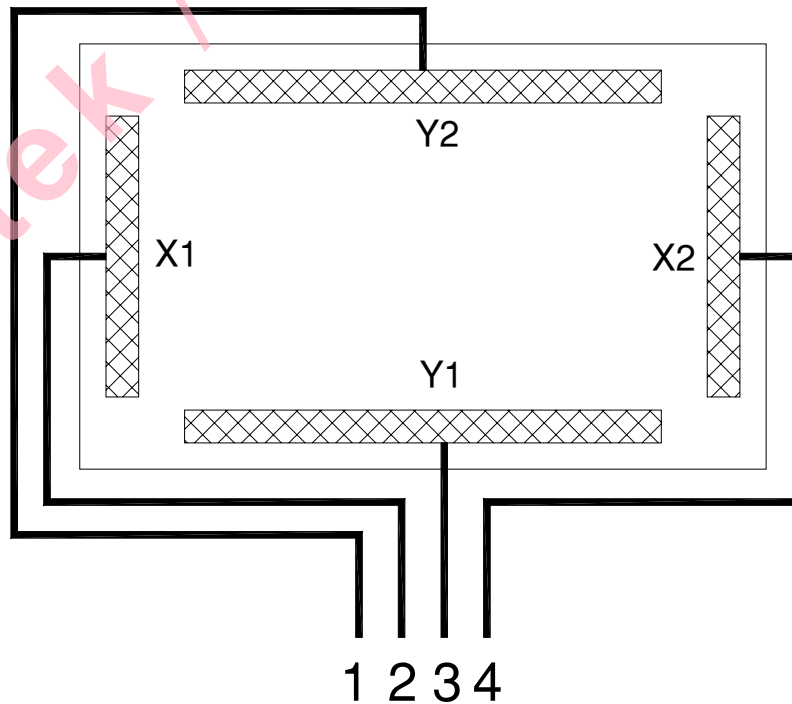

Fig. 2 Measuring area for Pen Sliding & Hitting Durability

#### 6.4. TOUCH PANEL CIRCUIT BLOCK



**7. OPTICAL CHARACTERISTICS**

( $T_a=+25$ ,  $VCC=+3.3V$ ,  $I_{BL}=40mA$ )

Item	Symbol	Condition	Values			Unit	Remark	
			Min.	Typ.	Max.			
Viewing Angle Range	Left	$\theta_L$	CR $\geq 10$	50	60	-	degree	Note 1,2
	Right	$\theta_R$		50	60	-		
	Top	$\Phi_T$		40	50	-		
	Botto	$\Phi_B$		55	65	-		
Response Time	$T_{on} + T_{off}$	Normal $\theta=\Phi=0^\circ$	-	30	50	ms	Note 2,3	
Contrast Ratio	CR	Normal $\theta=\Phi=0^\circ$	300	500	-	-	Note 2,4	
Luminance	L	Normal $\theta=\Phi=0^\circ$	280	310	-	cd/m <sup>2</sup>	Note 2,5	
Color Chromaticity (CIE1931)	White	$W_x$	Normal $\theta=\Phi=0^\circ$	0.2653	0.3153	0.3653	-	Note 2,6
		$W_y$		0.2909	0.3409	0.3909		
	Red	$R_x$		0.5562	0.6062	0.6562		
		$R_y$		0.3070	0.3570	0.4070		
	Green	$G_x$		0.3056	0.3556	0.4056		
		$G_y$		0.5346	0.5846	0.6346		
	Blue	$B_x$		0.0975	0.1475	0.1975		
		$B_y$		0.0553	0.1053	0.1553		
Color Gamut	NTSC	CIE1931	-	52	-	%	-	
Luminance Uniformity	$U_L$	Normal $\theta=\Phi=0^\circ$	75	80	-	%	Note 2,7	
Flicker		Normal $\theta=\Phi=0^\circ$	Not visible			-	Note 8	
Crosstalk		Normal $\theta=\Phi=0^\circ$	Not visible			-	Note 9	



Note 1: Definition of viewing angle range

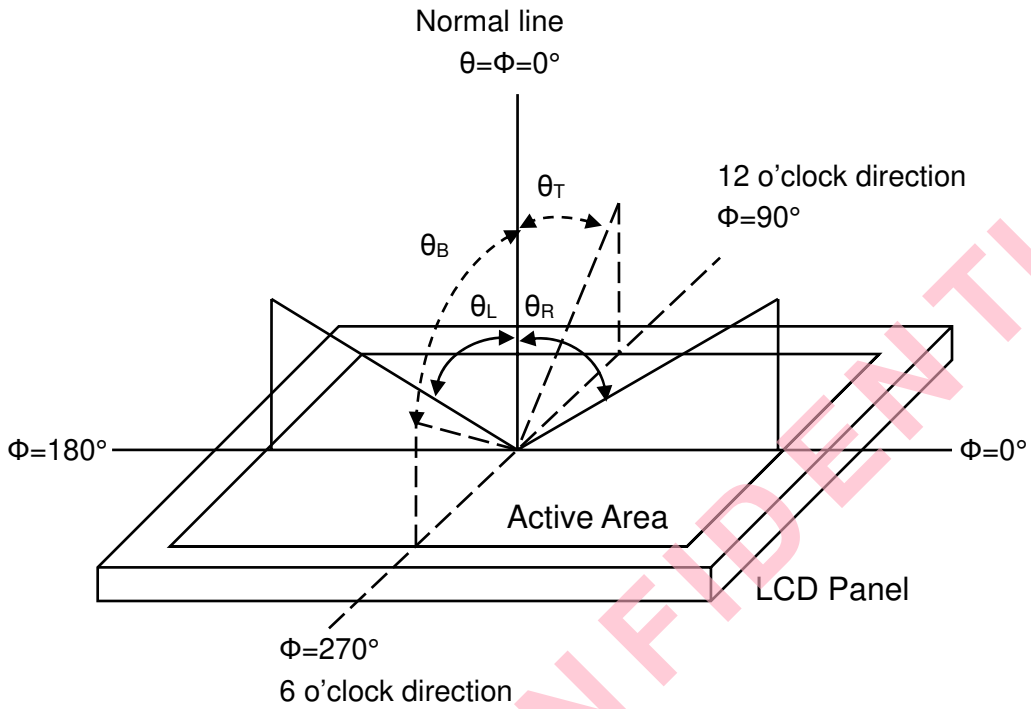

Fig. 1 Definition of viewing angle

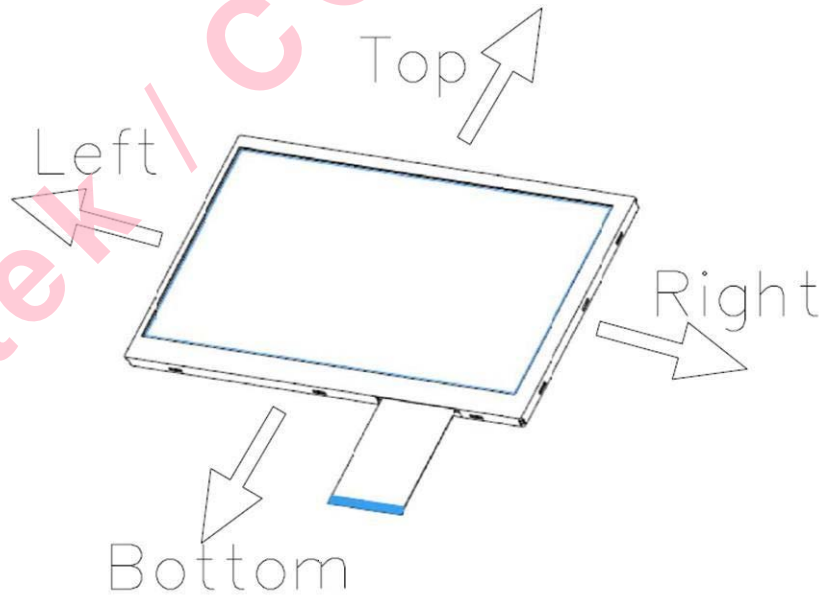

Fig. 2 Definition of viewing angle for display

Note 2: Definition of optical measurement system

The optical characteristics should be measured in a dark room with ambient temperature  $T_a=+25^{\circ}\text{C}$ . The optical properties are measured at the center point of the LCD screen after 5 minutes operation. (Equipment: Photo detector TOPCON BM-7 Field of view:  $1^{\circ}$ /Height: 500mm.)

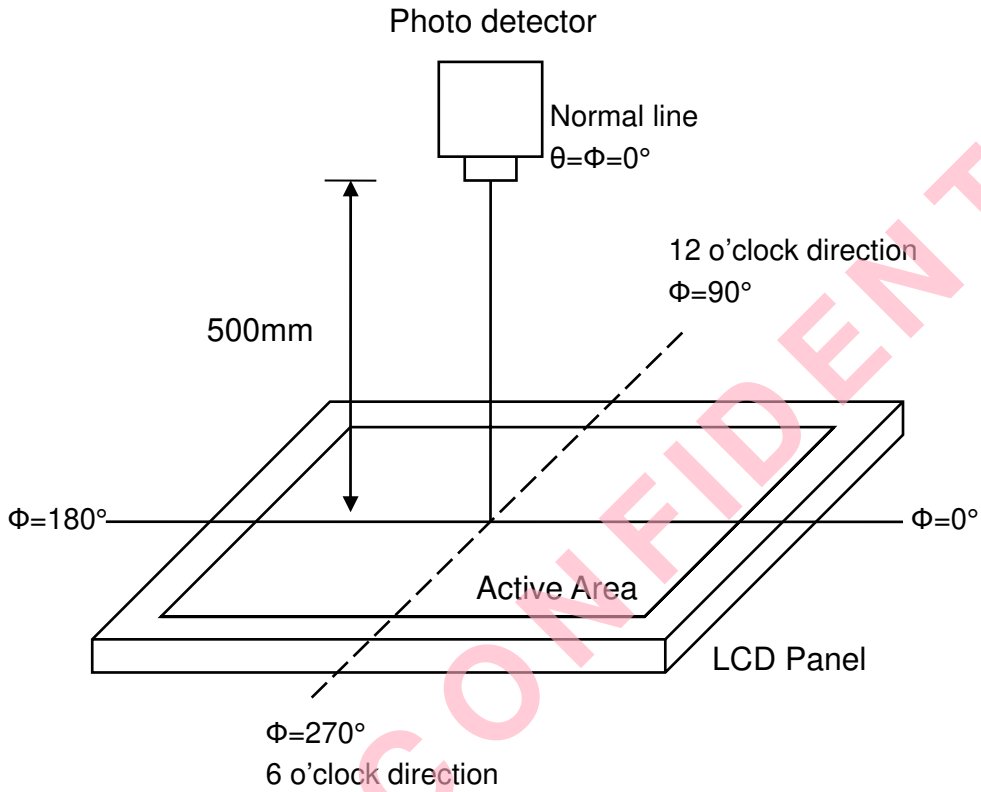

Fig. 3 Optical measurement system setup

Note 3: Definition of response time

The response time is defined as the LCD optical switching time interval between “White” state and “Black” state. Rise time ( $T_{on}$ ) is the time between photo detector output intensity changed from 90% to 10%, and fall time ( $T_{off}$ ) is the time between photo detector output intensity changed from 10% to 90%.

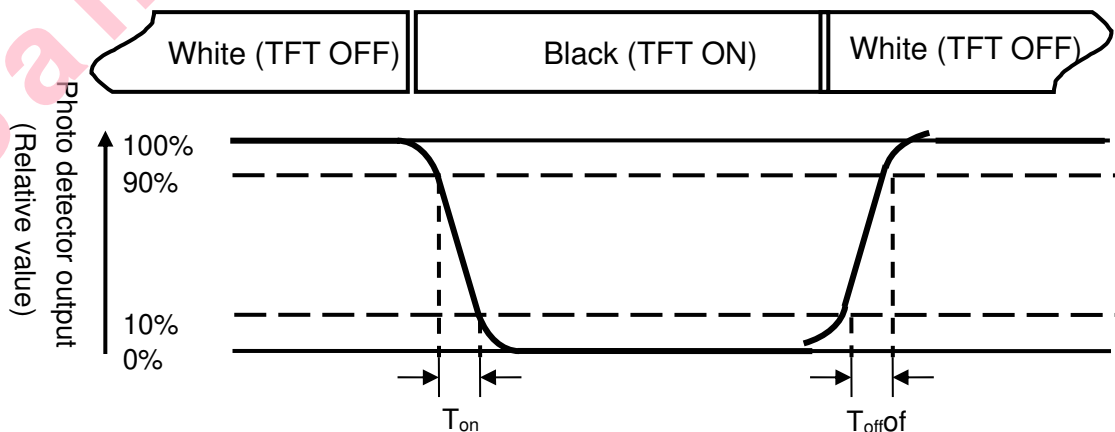

Fig. 4 Definition of response time

Note 4: Definition of contrast ratio

$$\text{Contrast ratio (CR)} = \frac{\text{Luminance measured when LCD on the "White" state}}{\text{Luminance measured when LCD on the "Black" state}}$$

Note 5: Definition of luminance

Measured at the center area of the panel when LCD panel is driven at "white" state.

Note 6: Definition of color chromaticity (CIE1931)

Color coordinates measured at the center point of LCD when panel is driven at "White", "Red", "Green" and "Blue" state respectively.

Note 7: Definition of luminance uniformity

To test for uniformity, the tested area is divided into 3 rows and 3 columns. The measurement spot is placed at the center of each circle as below.

$$\text{Luminance Uniformity (U}_L\text{)} = \frac{L_{\min}}{L_{\max}}$$

L-----Active area length      W----- Active area width

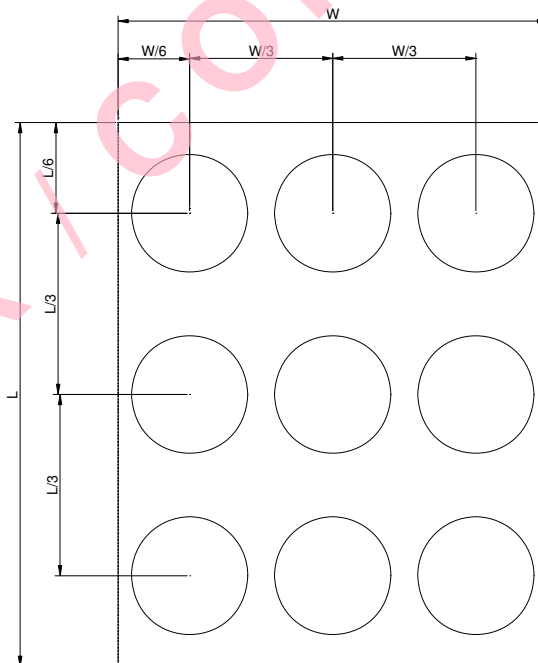

Fig. 5 Definition of luminance uniformity

$L_{\min}$  : The measured minimum luminance of all measurement position.

$L_{\max}$  : The measured maximum luminance of all measurement position.

Note 8: Definition of flicker

Flicker is the pattern usually used to describe the visual sensation produced by a rapidly varying light intensity. There should be no visible flicker in normal direction of the display when the following figure are loaded. The figure is composed of interlaced black and white lines.

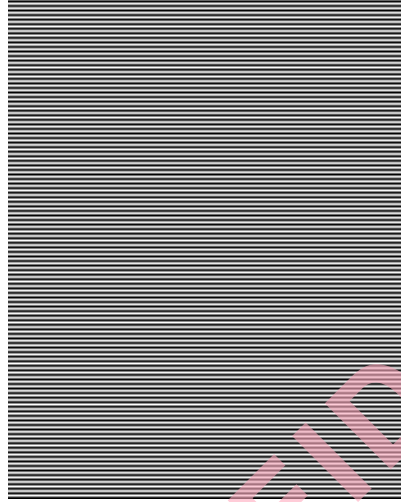

Fig.6 Flicker checker pattern

Note 9: Definition of crosstalk

There should be no visible in normal direction of the display when the following figures are loaded.

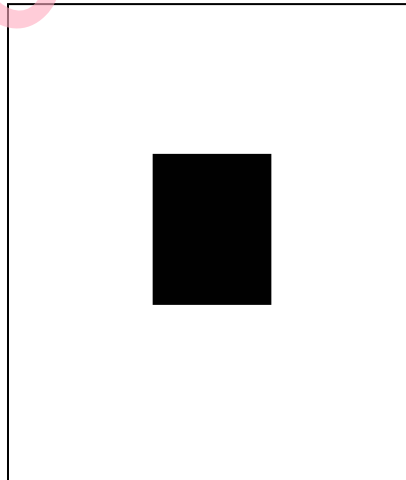

Fig.7 Crosstalk checker pattern

**8. RELIABILITY TESTS**

ITEM	CONDITION	CRITERION
Operating Temperature Test	High Temperature: +70 °C±2°C, 120hrs	No defects in display and operational functions
	Low Temperature: -20 °C±2°C, 120 hrs	
Storage Temperature Test	High Temperature: +80 °C±3°C, 120 hrs	No defects in display and operational functions
	Low Temperature: -30 °C±3°C, 120 hrs	
High Temp & High Humidity	60 °C, 90%RH, 120 hrs	No defects in display and operational functions
Thermal Shock Test	-30 °C (0.5 hrs) ↔ +80 °C(0.5 hrs) 50 cycles	No defects in display and operational functions
Vibration Test	Package Operating Time: 60 minutes exposure for each Y direction Sweep Frequency: 10~55Hz (1 min) Amplitude: 1.5mm Speed: 20m/s <sup>2</sup>	No defects in display and operational functions
Package Drop Test	Height : 1.0m (Weight ≤ 10kg); 60cm (Weight ≥ 10kg) 1 corner, 3 edges, 6 surfaces	No defects in display and operational functions
Electro Static Discharge	± 2KV, Human Body Mode, 100pF/1500Ω ± 8KV, Air Mode, 100pF/1500Ω	No defects in display and operational functions

NOTE:

- 1) The samples must be free from defect before test, must be restored at room condition at least for 2 hours after reliability test before any inspection.
- 2) After a long period of high temperature, the surrounding edge of the LCM all-black image will appear Mura phenomenon, which is a normal phenomenon.

## 9. INSPECTION CRITERION

### 9.1. SAMPLING METHOD

Unless otherwise agreed upon in writing, the sampling inspection shall be applied to the Customer's incoming inspection.

- 1) Lot size: Quantity per shipment lot
- 2) Sampling type: Normal inspection , single sampling
- 3) Inspection level: II
- 4) Sampling table: MIL-STD-105D
- 5) Acceptable Quality Level(AQL): Major=0.65 Minor=1.5

### 9.2. INSPECTION METHOD

- 1) Ambient Condition:
  - a. Temperature: Room temperature  $25 \pm 5^\circ\text{C}$
  - b. Illumination: Single fluorescent lamp non-directive(300 to 700 Lux)
- 2) Viewing distance  
The distance between the LCD and the inspector's eyes shall be at least 30-50cm.
- 3) Viewing Angle  
The inspection shall be conducted within normal viewing angle range.

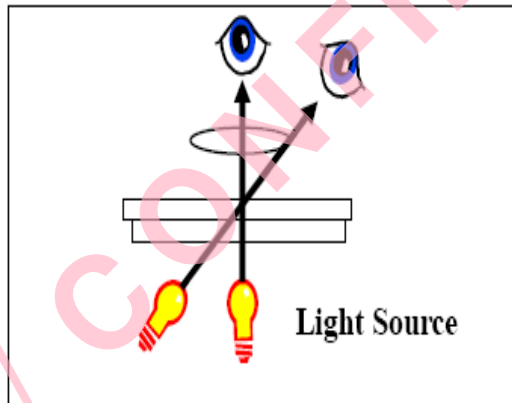



### 9.3. INSPECTION CRITERIA

#### 9.3.1. Major defect

No.	Item	Inspection Standard	Classification of defects
1	All functional defects	1) No display 2) Display abnormally 3) Open or missing segment 4) Short circuit 5) Excess power consumption 6) Backlight no lighting, flickering and abnormal lighting	Major
2	Missing	Missing component	Major
3	Outline dimension	Overall outline dimension beyond the drawing is not allowed	Major

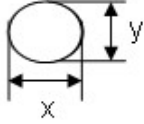
9.3.2. Cosmetic Defect

No.	Item	Inspection Standard		Classification of defects										
1	(spot defect) Black and White spot pinhole	For dark/white spot, size $\Phi$ is defined as $\Phi=(x+y)/2$		Minor										
		<table border="1"> <thead> <tr> <th>Size <math>\Phi</math> (mm)</th> <th>Acceptable Quantity</th> </tr> </thead> <tbody> <tr> <td><math>\Phi \leq 0.1</math></td> <td>Ignore</td> </tr> <tr> <td><math>0.10 \leq \Phi \leq 0.15</math></td> <td>2</td> </tr> <tr> <td><math>0.15 \leq \Phi \leq 0.2</math></td> <td>1</td> </tr> <tr> <td><math>0.2 &lt; \Phi</math></td> <td>0</td> </tr> </tbody> </table>	Size $\Phi$ (mm)		Acceptable Quantity	$\Phi \leq 0.1$	Ignore	$0.10 \leq \Phi \leq 0.15$	2	$0.15 \leq \Phi \leq 0.2$	1	$0.2 < \Phi$	0	
		Size $\Phi$ (mm)	Acceptable Quantity											
		$\Phi \leq 0.1$	Ignore											
		$0.10 \leq \Phi \leq 0.15$	2											
$0.15 \leq \Phi \leq 0.2$	1													
$0.2 < \Phi$	0													
2	(line defect) Black and White line Polarizer scratch	Define: 		Minor										
		<table border="1"> <thead> <tr> <th>Width(mm)</th> <th>Length(mm); Acceptable Qty</th> </tr> </thead> <tbody> <tr> <td><math>\Phi \leq 0.03</math></td> <td>Ignore</td> </tr> <tr> <td><math>0.03 &lt; W \leq 0.05</math></td> <td><math>L \leq 3.0</math>; <math>N \leq 2</math></td> </tr> <tr> <td><math>0.05 &lt; W \leq 0.1</math></td> <td><math>L \leq 2.0</math>; <math>N \leq 2</math></td> </tr> <tr> <td><math>0.1 &lt; W</math></td> <td>Define as spot defect</td> </tr> </tbody> </table>	Width(mm)		Length(mm); Acceptable Qty	$\Phi \leq 0.03$	Ignore	$0.03 < W \leq 0.05$	$L \leq 3.0$ ; $N \leq 2$	$0.05 < W \leq 0.1$	$L \leq 2.0$ ; $N \leq 2$	$0.1 < W$	Define as spot defect	
		Width(mm)	Length(mm); Acceptable Qty											
		$\Phi \leq 0.03$	Ignore											
		$0.03 < W \leq 0.05$	$L \leq 3.0$ ; $N \leq 2$											
$0.05 < W \leq 0.1$	$L \leq 2.0$ ; $N \leq 2$													
$0.1 < W$	Define as spot defect													
3	Polarizer defect	Dent or bubble (between the polarizer and glass)		Minor										
		<table border="1"> <thead> <tr> <th>Size <math>\Phi</math>(mm)</th> <th>Acceptable Qty</th> </tr> </thead> <tbody> <tr> <td><math>\Phi \leq 0.10</math></td> <td>Ignor</td> </tr> <tr> <td><math>0.10 &lt; \Phi \leq 0.20</math></td> <td>2</td> </tr> <tr> <td><math>0.20 &lt; \Phi \leq 0.30</math></td> <td>1</td> </tr> <tr> <td><math>0.30 &lt; \Phi</math></td> <td>0</td> </tr> </tbody> </table>	Size $\Phi$ (mm)		Acceptable Qty	$\Phi \leq 0.10$	Ignor	$0.10 < \Phi \leq 0.20$	2	$0.20 < \Phi \leq 0.30$	1	$0.30 < \Phi$	0	
		Size $\Phi$ (mm)	Acceptable Qty											
		$\Phi \leq 0.10$	Ignor											
		$0.10 < \Phi \leq 0.20$	2											
$0.20 < \Phi \leq 0.30$	1													
$0.30 < \Phi$	0													

9.3.3. Cosmetic Defect

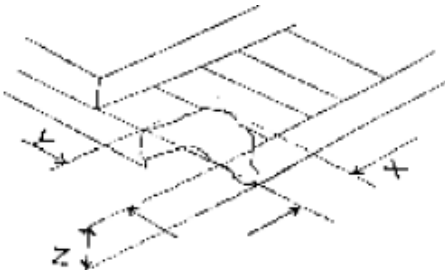
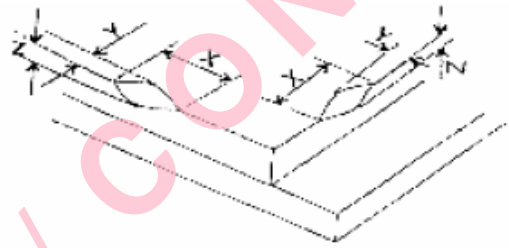
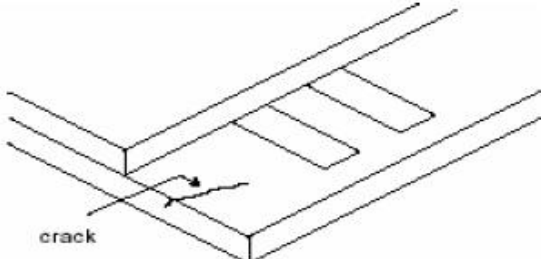
No.	Item	Inspection Standard	Classification of defects						
1	Glass defect	<p>1) Chip on the corner</p>  <table border="1" data-bbox="491 716 1129 813"> <tr> <td>X</td> <td>Y</td> <td>Z</td> </tr> <tr> <td>≤3.0</td> <td>≤S</td> <td>≤T</td> </tr> </table> <p>Remark: S=contact pad length; T=the thickness of glass Chips on the corner of terminal shall not be allowed to extend into the ITO pad or expose perimeter seal. Acceptable Quantity N≤2.</p>	X	Y	Z	≤3.0	≤S	≤T	Minor
		X	Y	Z					
		≤3.0	≤S	≤T					
<p>2) Chip on the edge of glass</p>  <table border="1" data-bbox="491 1310 1129 1417"> <tr> <td>X</td> <td>Y</td> <td>Z</td> </tr> <tr> <td>Ignore</td> <td>≤0.5</td> <td>≤T</td> </tr> </table> <p>Acceptable Quantity: N≤2</p>	X	Y	Z	Ignore	≤0.5	≤T	Minor		
X	Y	Z							
Ignore	≤0.5	≤T							
<p>3) Creak</p> <p>Creaks tend to break are not allowed.</p> 	Minor								



---

**10. PACKAGE DRAWING**

**Santek / CONFIDENTIAL**

## 11. PRECAUTIONS

### 11.1. HANDLING

11.1.1. Polarizer cleaning, Petroleum ether (or N-hexane) is recommended for cleaning the front/rear polarizers and reflectors, acetone, toluene and ethanol are not allowed to avoid damaging the surface.

11.1.2. Body grounding, must wear Anti-ESD wrist strap while pick up LCDs.

11.1.3. FPC soldering, less than 300 °C/3S, solder must be grounding on grounding bench.

11.1.4. If use electric Screwdriver to do assembly, screwdriver must be grounding.

### 11.2. STORAGE

11.2.1. Keep in a sealed polyethylene bag.

11.2.2. Keep in a dark place.

11.2.3. Keep in temperature between 0°C and 35°C.

NOT allowed at 70°C for more than 160 Hours, or at -20°C for more than 48 Hrs.

### 11.3. SAFETY

If liquid crystal leak out of a damaged glass cell, do not put it in your mouth or touch eyes, if the liquid crystal touch your skin or clothes, please wash it off immediately using soap and water.

## 12. LIMITED WARRANTY

Unless otherwise agreed between SANTEK and customer, SANTEK will replace or repair any of its LCD modules which are found to be functionally defective when inspected in accordance with SANTEK LCD acceptance standards (copies available upon request) for a period of one year from date of shipments. Cosmetic/visual defects over specs must be returned to SANTEK within 30 days of shipment. Confirmation of such date shall be based on freight documents. The warranty liability of SANTEK limited to repair and/or replacement on the terms set forth above. SANTEK shall not be responsible for any subsequent or consequential events.

### 12.1. RETURNING LCM UNDER WARRANTY – TERMS AND CONDITIONS

12.1.1. No warranty can be granted if the precautions stated above have been disregarded. The typical examples of violations are :

- Broken LCD glass.
- Circuit modified in any way, including addition of components.

12.1.2. Module repairs will be invoiced to the customer upon mutual agreement. Modules must be returned with sufficient description of the failures or defects. Any connectors or cable installed by the customer must be removed completely without damaging the PCB's eyelet, conductors and terminals.