



MICROCHIP

**MIC28514
Evaluation Board
User's Guide**

Note the following details of the code protection feature on Microchip devices:

- Microchip products meet the specification contained in their particular Microchip Data Sheet.
- Microchip believes that its family of products is one of the most secure families of its kind on the market today, when used in the intended manner and under normal conditions.
- There are dishonest and possibly illegal methods used to breach the code protection feature. All of these methods, to our knowledge, require using the Microchip products in a manner outside the operating specifications contained in Microchip's Data Sheets. Most likely, the person doing so is engaged in theft of intellectual property.
- Microchip is willing to work with the customer who is concerned about the integrity of their code.
- Neither Microchip nor any other semiconductor manufacturer can guarantee the security of their code. Code protection does not mean that we are guaranteeing the product as "unbreakable."

Code protection is constantly evolving. We at Microchip are committed to continuously improving the code protection features of our products. Attempts to break Microchip's code protection feature may be a violation of the Digital Millennium Copyright Act. If such acts allow unauthorized access to your software or other copyrighted work, you may have a right to sue for relief under that Act.

Information contained in this publication regarding device applications and the like is provided only for your convenience and may be superseded by updates. It is your responsibility to ensure that your application meets with your specifications. MICROCHIP MAKES NO REPRESENTATIONS OR WARRANTIES OF ANY KIND WHETHER EXPRESS OR IMPLIED, WRITTEN OR ORAL, STATUTORY OR OTHERWISE, RELATED TO THE INFORMATION, INCLUDING BUT NOT LIMITED TO ITS CONDITION, QUALITY, PERFORMANCE, MERCHANTABILITY OR FITNESS FOR PURPOSE. Microchip disclaims all liability arising from this information and its use. Use of Microchip devices in life support and/or safety applications is entirely at the buyer's risk, and the buyer agrees to defend, indemnify and hold harmless Microchip from any and all damages, claims, suits, or expenses resulting from such use. No licenses are conveyed, implicitly or otherwise, under any Microchip intellectual property rights unless otherwise stated.

Microchip received ISO/TS-16949:2009 certification for its worldwide headquarters, design and wafer fabrication facilities in Chandler and Tempe, Arizona; Gresham, Oregon and design centers in California and India. The Company's quality system processes and procedures are for its PIC® MCUs and dsPIC® DSCs, KEELOQ® code hopping devices, Serial EEPROMs, microperipherals, nonvolatile memory and analog products. In addition, Microchip's quality system for the design and manufacture of development systems is ISO 9001:2000 certified.

**QUALITY MANAGEMENT SYSTEM
CERTIFIED BY DNV
= ISO/TS 16949 =**

Trademarks

The Microchip name and logo, the Microchip logo, AnyRate, AVR, AVR logo, AVR Freaks, BeaconThings, BitCloud, CryptoMemory, CryptoRF, dsPIC, FlashFlex, flexPWR, Helder, JukeBlox, KEELOQ, KEELOQ logo, Klear, LANCheck, LINK MD, maXStylus, maXTouch, MediaLB, megaAVR, MOST, MOST logo, MPLAB, OptoLyzr, PIC, picoPower, PICSTART, PIC32 logo, Prochip Designer, QTouch, RightTouch, SAM-BA, SpyNIC, SST, SST Logo, SuperFlash, tinyAVR, UNI/O, and XMEGA are registered trademarks of Microchip Technology Incorporated in the U.S.A. and other countries.

ClockWorks, The Embedded Control Solutions Company, EtherSynch, Hyper Speed Control, HyperLight Load, IntelliMOS, mTouch, Precision Edge, and Quiet-Wire are registered trademarks of Microchip Technology Incorporated in the U.S.A.

Adjacent Key Suppression, AKS, Analog-for-the-Digital Age, Any Capacitor, AnyIn, AnyOut, BodyCom, chipKIT, chipKIT logo, CodeGuard, CryptoAuthentication, CryptoCompanion, CryptoController, dsPICDEM, dsPICDEM.net, Dynamic Average Matching, DAM, ECAN, EtherGREEN, In-Circuit Serial Programming, ICSP, Inter-Chip Connectivity, JitterBlocker, KlearNet, KlearNet logo, Mindi, MiWi, motorBench, MPASM, MPF, MPLAB Certified logo, MPLIB, MPLINK, MultiTRAK, NetDetach, Omniscient Code Generation, PICDEM, PICDEM.net, PICKit, PICtail, PureSilicon, QMatrix, RightTouch logo, REAL ICE, Ripple Blocker, SAM-ICE, Serial Quad I/O, SMART-I.S., SQI, SuperSwitcher, SuperSwitcher II, Total Endurance, TSHARC, USBCheck, VariSense, ViewSpan, WiperLock, Wireless DNA, and ZENA are trademarks of Microchip Technology Incorporated in the U.S.A. and other countries.

SQTP is a service mark of Microchip Technology Incorporated in the U.S.A.

Silicon Storage Technology is a registered trademark of Microchip Technology Inc. in other countries.

GestIC is a registered trademark of Microchip Technology Germany II GmbH & Co. KG, a subsidiary of Microchip Technology Inc., in other countries.

All other trademarks mentioned herein are property of their respective companies.

© 2017, Microchip Technology Incorporated, All Rights Reserved.
ISBN: 978-1-5224-1724-8

Object of Declaration: MIC28514 Evaluation Board User's Guide

EU Declaration of Conformity

This declaration of conformity is issued by the manufacturer.

The development/evaluation tool is designed to be used for research and development in a laboratory environment. This development/evaluation tool is not a Finished Appliance, nor is it intended for incorporation into Finished Appliances that are made commercially available as single functional units to end users under EU EMC Directive 2004/108/EC and as supported by the European Commission's Guide for the EMC Directive 2004/108/EC (8th February 2010).

This development/evaluation tool complies with EU RoHS2 Directive 2011/65/EU.

This development/evaluation tool, when incorporating wireless and radio-telecom functionality, is in compliance with the essential requirement and other relevant provisions of the R&TTE Directive 1999/5/EC and the FCC rules as stated in the declaration of conformity provided in the module datasheet and the module product page available at www.microchip.com.

For information regarding the exclusive, limited warranties applicable to Microchip products, please see Microchip's standard terms and conditions of sale, which are printed on our sales documentation and available at www.microchip.com.

Signed for and on behalf of Microchip Technology Inc. at Chandler, Arizona, USA.

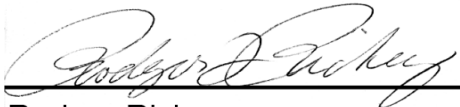

Rodger Richey
Director of Development Tools



Date

NOTES:



MIC28514 EVALUATION BOARD USER'S GUIDE

Table of Contents

Preface	7
Introduction.....	7
Document Layout	7
Conventions Used in this Guide	8
Recommended Reading.....	9
The Microchip Web Site	9
Customer Support	9
Document Revision History	9
Chapter 1. Product Overview	
1.1 Introduction	11
1.2 MIC28514 Evaluation Board Overview	11
1.3 MIC28514 Evaluation Board Features	12
1.4 What the MIC28514 Evaluation Board Kit Contains	12
Chapter 2. Installation and Operation	
2.1 System and Configuration Requirements	13
2.2 Board Setup	13
2.3 Circuit Description	14
2.3.1 Feedback Resistors	14
2.3.2 SW Node	15
2.3.3 Current Limit	15
2.3.4 Loop Gain Measurement	15
2.3.5 Setting the Switching Frequency	15
2.3.6 Setting the Soft Start Time	16
2.3.7 Auxiliary Bootstrap LDO (EXTVDD)	16
Appendix A. Schematic and Layouts	
A.1 Introduction	17
A.2 Board – Schematic	18
A.3 Board – Top Silk	19
A.4 Board – Top Copper and Silk	19
A.5 Board – Top Copper	20
A.6 Board – MID Copper Layer 1	20
A.7 Board – Mid Copper Layer 2	21
A.8 Board – Bottom Copper	21
A.9 Board – Bottom Copper and Silk	22
Appendix B. Bill of Materials (BOM)	23
Worldwide Sales and Service	26

MIC28514 Evaluation Board User's Guide



MIC28514 EVALUATION BOARD USER'S GUIDE

Preface

NOTICE TO CUSTOMERS

All documentation becomes dated, and this manual is no exception. Microchip tools and documentation are constantly evolving to meet customer needs, so some actual dialogs and/or tool descriptions may differ from those in this document. Please refer to our web site (www.microchip.com) to obtain the latest documentation available.

Documents are identified with a “DS” number. This number is located on the bottom of each page, in front of the page number. The numbering convention for the DS number is “DSXXXXXXXXA”, where “XXXXXXXX” is the document number and “A” is the revision level of the document.

For the most up-to-date information on development tools, see the MPLAB® IDE online help. Select the Help menu, and then Topics, to open a list of available online help files.

INTRODUCTION

This chapter contains general information that will be useful to know before using the MIC28514 Evaluation Board. Items discussed in this chapter include:

- [Document Layout](#)
- [Conventions Used in this Guide](#)
- [Recommended Reading](#)
- [The Microchip Website](#)
- [Customer Support](#)
- [Document Revision History](#)

DOCUMENT LAYOUT

This document describes how to use the MIC28514 Evaluation Board as a development tool to emulate and debug firmware on a target board. The manual layout is as follows:

- **Chapter 1. “Product Overview”** – Important information about the MIC28514 Evaluation Board.
- **Chapter 2. “Installation and Operation”** – Includes instructions on installing and starting the MIC28514 Evaluation Board.
- **Appendix A. “Schematic and Layouts”** – Shows the schematic and layout diagrams for the MIC28514 Evaluation Board.
- **Appendix B. “Bill of Materials (BOM)”** – Lists the parts used to build the MIC28514 Evaluation Board.

MIC28514 Evaluation Board User's Guide

CONVENTIONS USED IN THIS GUIDE

This manual uses the following documentation conventions:

DOCUMENTATION CONVENTIONS

Description	Represents	Examples
Arial font:		
Italic characters	Referenced books	<i>MPLAB® IDE User's Guide</i>
	Emphasized text	...is the <i>only</i> compiler...
Initial caps	A window	the Output window
	A dialog	the Settings dialog
	A menu selection	select Enable Programmer
Quotes	A field name in a window or dialog	"Save project before build"
Underlined, italic text with right angle bracket	A menu path	<u><i>File</i></u> >Save
Bold characters	A dialog button	Click OK
	A tab	Click the Power tab
N'Rnnnn	A number in verilog format, where N is the total number of digits, R is the radix and n is a digit.	4'b0010, 2'hF1
Text in angle brackets < >	A key on the keyboard	Press <Enter>, <F1>
Courier New font:		
Plain Courier New	Sample source code	#define START
	Filenames	autoexec.bat
	File paths	c:\mcc18\h
	Keywords	_asm, _endasm, static
	Command-line options	-Opa+, -Opa-
	Bit values	0, 1
	Constants	0xFF, 'A'
Italic Courier New	A variable argument	<i>file.o</i> , where <i>file</i> can be any valid filename
Square brackets []	Optional arguments	mcc18 [options] <i>file</i> [options]
Curly brackets and pipe character: { }	Choice of mutually exclusive arguments; an OR selection	errorlevel {0 1}
Ellipses...	Replaces repeated text	var_name [, var_name...]
	Represents code supplied by user	void main (void) { ... }

RECOMMENDED READING

This user's guide describes how to use the MIC28514 Evaluation Board. Another useful document is listed below. The following Microchip document is available and recommended as a supplemental reference resource:

- **MIC28514 Data Sheet – “75V/5A Hyper Speed Control® Synchronous DC/DC Buck Regulator with External Soft Start” (DS20005693)**

THE MICROCHIP WEBSITE

Microchip provides online support via our website at www.microchip.com. This website is used as a means to make files and information easily available to customers. Accessible by using your favorite Internet browser, the website contains the following information:

- **Product Support** – Data sheets and errata, application notes and sample programs, design resources, user's guides and hardware support documents, latest software releases and archived software
- **General Technical Support** – Frequently Asked Questions (FAQs), technical support requests, online discussion groups, Microchip consultant program member listing
- **Business of Microchip** – Product selector and ordering guides, latest Microchip press releases, listing of seminars and events, listings of Microchip sales offices, distributors and factory representatives

CUSTOMER SUPPORT

Users of Microchip products can receive assistance through several channels:

- Distributor or Representative
- Local Sales Office
- Field Application Engineer (FAE)
- Technical Support

Customers should contact their distributor, representative or field application engineer (FAE) for support. Local sales offices are also available to help customers. A listing of sales offices and locations is included in the back of this document.

Technical support is available through the website at:
<http://www.microchip.com/support>.

DOCUMENT REVISION HISTORY

Revision B (May 2017)

- Updated Figure 2-1.

Revision A (February 2017)

- Initial Release of this Document.

MIC28514 Evaluation Board User's Guide

NOTES:

Chapter 1. Product Overview

1.1 INTRODUCTION

This chapter provides an overview of the MIC28514 Evaluation Board and covers the following topics:

- [MIC28514 Evaluation Board Overview](#)
- [MIC28514 Evaluation Board Features](#)
- [What the MIC28514 Evaluation Board Kit Contains](#)

1.2 MIC28514 EVALUATION BOARD OVERVIEW

The MIC28514 Evaluation Board is a constant frequency, synchronous buck controller featuring a unique adaptive on-time control architecture. The MIC28514 operates over an input supply range of 4.5V to 75V. The output voltage is adjustable down to 0.6V with an ensured accuracy of $\pm 1\%$. The device operates with a programmable switching frequency from 270 kHz to 800 kHz.

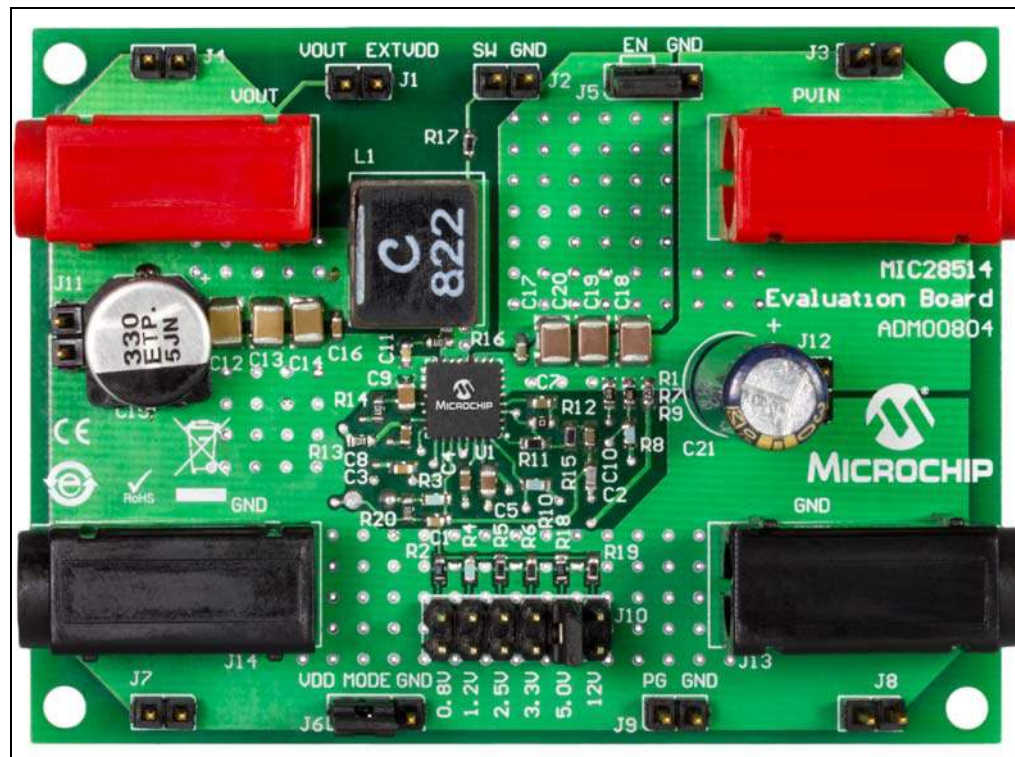

FIGURE 1-1: MIC28514 Evaluation Board.

MIC28514 Evaluation Board User's Guide

1.3 MIC28514 EVALUATION BOARD FEATURES

The MIC28514 Evaluation Board:

- Features a Soft Start (SS) time selection pin, which allows the user to adjust the output Soft Start time to reduce inrush current from mains during start-up.
- Features six selectable output voltages: 0.8V, 1.2V, 2.5V, 3.3V, 5V and 12V.
- Features an auxiliary bootstrap Low Dropout (LDO) which improves the system efficiency by supplying the internal bias power from the output of the converter.
- Features a logic level Enable (EN) signal that can be used to enable or disable the controller.
- Can start up monotonically into a pre-biased output.
- Features an open-drain Power Good signal (PG), which signals when the output is in regulation.

The basic parameters of the evaluation board are:

- Input: 10V to 75V (optimized for 48V)
- Output: 0.8V, 1.2V, 2.5V, 3.3V, 5V or 12V Selectable through jumper J10 at 5A (default option is set to 5V)
- 300 kHz Switching Frequency (adjustable from 270 kHz to 800 kHz)

1.4 WHAT THE MIC28514 EVALUATION BOARD KIT CONTAINS

The MIC28514 Evaluation Board includes the following items:

- MIC28514 Evaluation Board (ADM00804)
- Important Information Sheet

Chapter 2. Installation and Operation

2.1 SYSTEM AND CONFIGURATION REQUIREMENTS

The MIC28514 Evaluation Board requires only a single power supply with at least 5A current capability. The MIC28514 has an internal V_{DD} LDO so no external linear regulator is required to power the internal biasing of the IC. In applications with $V_{IN} < +5.5V$, PV_{DD} should be tied to V_{IN} to bypass the internal linear regulator. The output load can either be a passive or an active load.

Note: The MIC28514 Evaluation Board does not have reverse polarity protection. Applying a negative voltage to the V_{IN} and GND terminals may damage the device. The maximum V_{IN} of the board is rated at 75V. Exceeding 75V on the V_{IN} could damage the device.

2.2 BOARD SETUP

Follow these steps prior to using the MIC28514 Evaluation Board:

1. Connect a supply to the V_{IN} and GND terminals, paying attention to the polarity and the supply range ($10V < V_{IN} < 75V$). Monitor I_{IN} with a current meter, and the input voltage at the V_{IN} and GND terminals with a voltmeter. Do not apply power until Step 4.
2. Connect a load to the V_{OUT} and GND terminals. The load can be either a passive (resistive) or an active (electronic) type. A current meter may be placed between the V_{OUT} terminal and load to monitor the output current. Ensure the output voltage is monitored at the V_{OUT} terminal.
3. Enable input. An EN connector is provided on the evaluation board for users to easily access the enable feature. Applying an external logic signal on the EN pin to pull it low, or using a jumper to short the EN pin to GND, will shut off the output of the MIC28514 Evaluation Board.
4. Turn on the V_{IN} supply and verify that the output voltage is regulated to the specific selected voltage.

MIC28514 Evaluation Board User's Guide

2.3 CIRCUIT DESCRIPTION

This section describes the working principles and limitations that should be taken into account when using the MIC28514 Evaluation Board. The external components have been selected in order to optimize performance for the specific conditions of $V_{IN} = 48V$ and $V_{OUT} = 5V$. Although the application will behave correctly for other output and input voltages, further optimization (fine-tuning of the inductor, output capacitors and ripple injection components) can be done in order to improve efficiency and transient response.

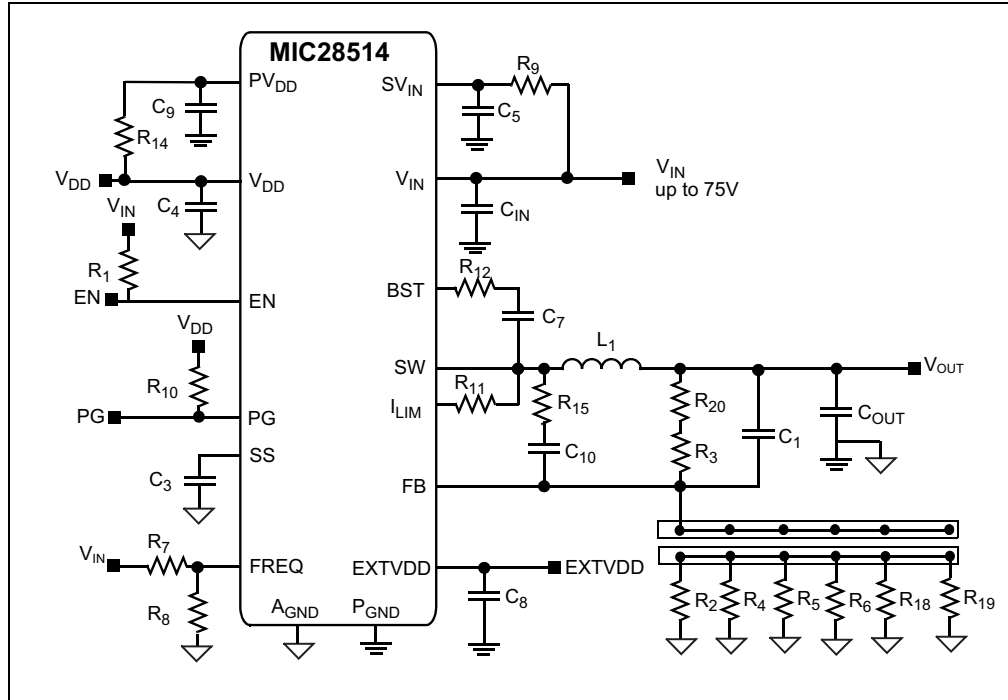

FIGURE 2-1: Evaluation Board Circuit Description.

2.3.1 Feedback Resistors

The output voltages available on the MIC28514 Evaluation Board are: 0.8V, 1.2V, 2.5V, 3.3V, 5V and 12V, which are selectable using jumper J10.

Voltages other than the ones already available can be set by modifying the R_{bot} resistors according to Equation 2-1.

EQUATION 2-1:

$$R_{bot} = \frac{R_3 \times V_{REF}}{V_{OUT} - V_{REF}}$$

Where:
 $V_{REF} = 0.6V$
 $R_3 = 10\text{ kOhm}$

Note that the output voltage should not be set to exceed 15V due to the 16V voltage rating on the output capacitors.

For output voltage higher than 15V, output capacitors of a voltage rating higher than the set output voltage should be used.

2.3.2 SW Node

Test point J2 (V_{SW}) is placed for monitoring the switching waveform, one of the most critical waveforms for the converter.

2.3.3 Current Limit

The MIC28514 Evaluation Board uses the low-side MOSFET $R_{DS(ON)}$ to sense inductor current. In each switching cycle of the MIC28514 converter, the inductor current is sensed by monitoring the voltage across the low-side MOSFET, during the off period of the switching cycle, during which the low-side MOSFET is on. An internal current source of 135 μA generates a voltage across the external Current-Limit Resistor, R_{CL} .

The I_{LIM} Pin Voltage (V_{ILIM}) is the difference of the voltage across the low-side MOSFET and the voltage across the resistor (V_{CL}). The sensed voltage, V_{ILIM} , is compared with the Power Ground (PGND) after a blanking time of 150 ns.

If the absolute value of the voltage drop across the low-side MOSFET is greater than the absolute value of the voltage across the current setting resistor (V_{CL}), the MIC28514 triggers the current-limit event. Consecutive eight current-limit events trigger the Hiccup mode. The hiccup sequence, including the Soft Start, reduces the stress on the internal MOSFETs, and protects the load and supply from severe short conditions.

The short-circuit current limit can be programmed by using the formula shown in [Equation 2-2](#).

EQUATION 2-2:

$$R_{II} = \frac{(I_{CLIM} + \Delta I_{LPP} \times 0.5) \times R_{DS(ON)}}{I_{CL}}$$

Where:

I_{CLIM} = Desired output current limit

ΔI_{LPP} = Inductor current peak-to-peak

$R_{DS(ON)}$ = On resistance of low-side power MOSFET(25 m Ω)

I_{CL} = Current-limit source current, the typical value is 135 μA

It is mandatory to make sure that the inductor current used to charge the output capacitance during Soft Start is under the current limit; otherwise, the supply will go into Hiccup mode and may not finish the Soft Start successfully.

The MOSFET $R_{DS(ON)}$ can vary up to 30%-40% with temperature. Therefore, it is recommended to add a 30% margin to the I_{CLIM} in the above equation to avoid false current limiting due to an increased MOSFET junction temperature rise.

2.3.4 Loop Gain Measurement

Resistor R20 is placed in series with the regulator feedback path. The control loop gain can be measured by connecting an impedance analyzer across the resistor and selecting the resistor value between 10 Ω to 50 Ω .

2.3.5 Setting the Switching Frequency

The MIC28514 Evaluation Board is an adjustable frequency, synchronous buck converter featuring a unique adaptive on-time control architecture. The switching frequency can be adjusted between 270 kHz and 800 kHz by changing the resistor divider network consisting of R_7 and R_8 .

MIC28514 Evaluation Board User's Guide

Equation 2-3 shows the estimated switching frequency:

EQUATION 2-3:

$$f_{SW} = f_0 \times \frac{R_8}{R_7 + R_8}$$

Where:

f_0 = Switching Frequency when FREQ pin is connected to the input voltage, f_0 is typically 800 kHz

The evaluation board design is optimized for a switching frequency of 300 kHz. If the switching frequency is programmed to either lower end or higher end, the design needs optimization.

2.3.6 Setting the Soft Start Time

The output voltage Soft Start time can be set by connecting a capacitor from SS to A_{GND} .

The value of the capacitor can be calculated using Equation 2-4:

EQUATION 2-4:

$$C_3 = \frac{I_{SS} \times t_{SS}}{V_{REF}}$$

Where:

C_3 = Capacitor from SS pin to A_{GND}

I_{SS} = Internal Soft Start current (1.4 μ A typical)

t_{SS} = Output Soft Start time

V_{REF} = Reference voltage (0.6V)

2.3.7 Auxiliary Bootstrap LDO (EXTVDD)

The MIC28514 Evaluation Board features an auxiliary bootstrap LDO which improves the system efficiency by supplying the MIC28514 internal circuit bias power from the converter output voltage. This LDO is enabled when the voltage on the EXTVDD pin is above 4.6V (typical), and at the same time, the main LDO, which operates from V_{IN} , is disabled to reduce power consumption. If the regulator output voltage is $\geq 5V$ and $\leq 12V$, use the output voltage to power the MIC28514, which will increase system efficiency. The J1 jumper can be shorted to use the output voltage as EXTVDD.



MIC28514 EVALUATION BOARD USER'S GUIDE

Appendix A. Schematic and Layouts

A.1 INTRODUCTION

This appendix contains the following schematics and layouts for the MIC28514 Evaluation Board:

- [Board – Schematic](#)
- [Board – Top Silk](#)
- [Board – Top Copper and Silk](#)
- [Board – Top Copper](#)
- [Board – MID Copper Layer 1](#)
- [Board – Mid Copper Layer 2](#)
- [Board – Bottom Copper](#)
- [Board – Bottom Copper and Silk](#)

A.3 BOARD – TOP SILK

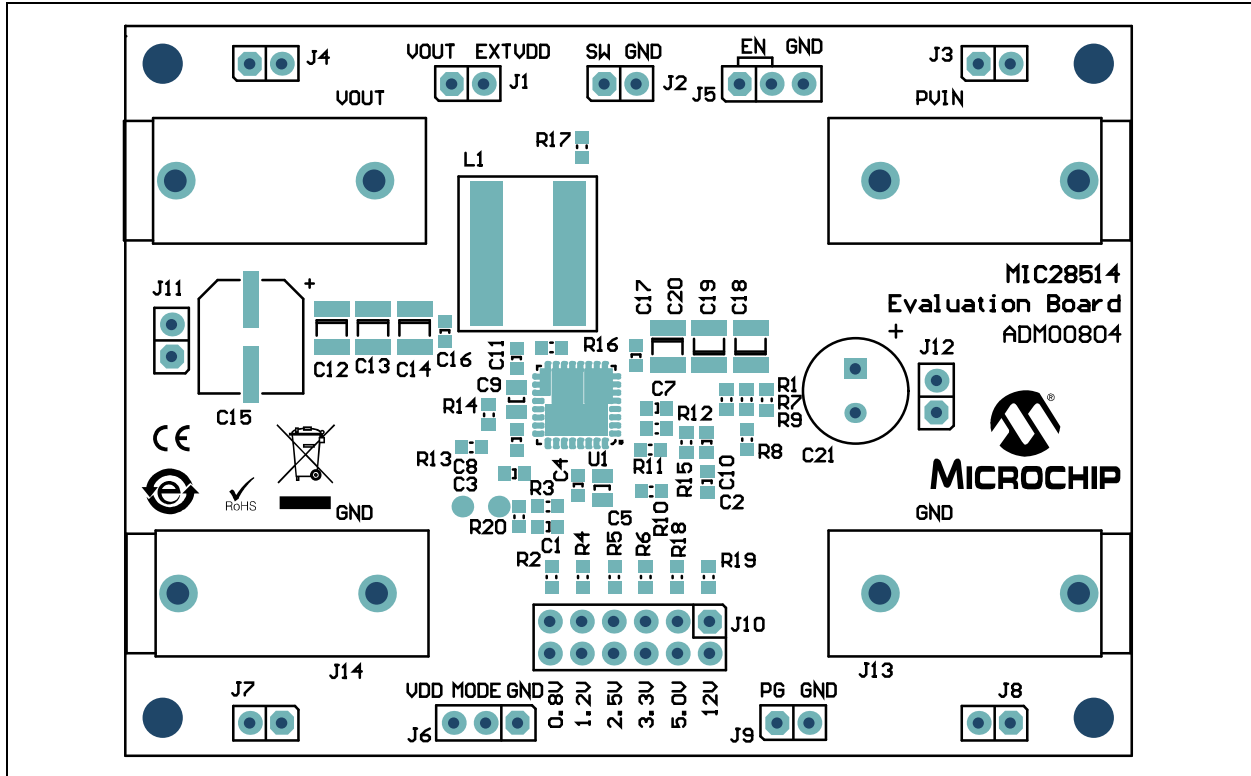

A.4 BOARD – TOP COPPER AND SILK

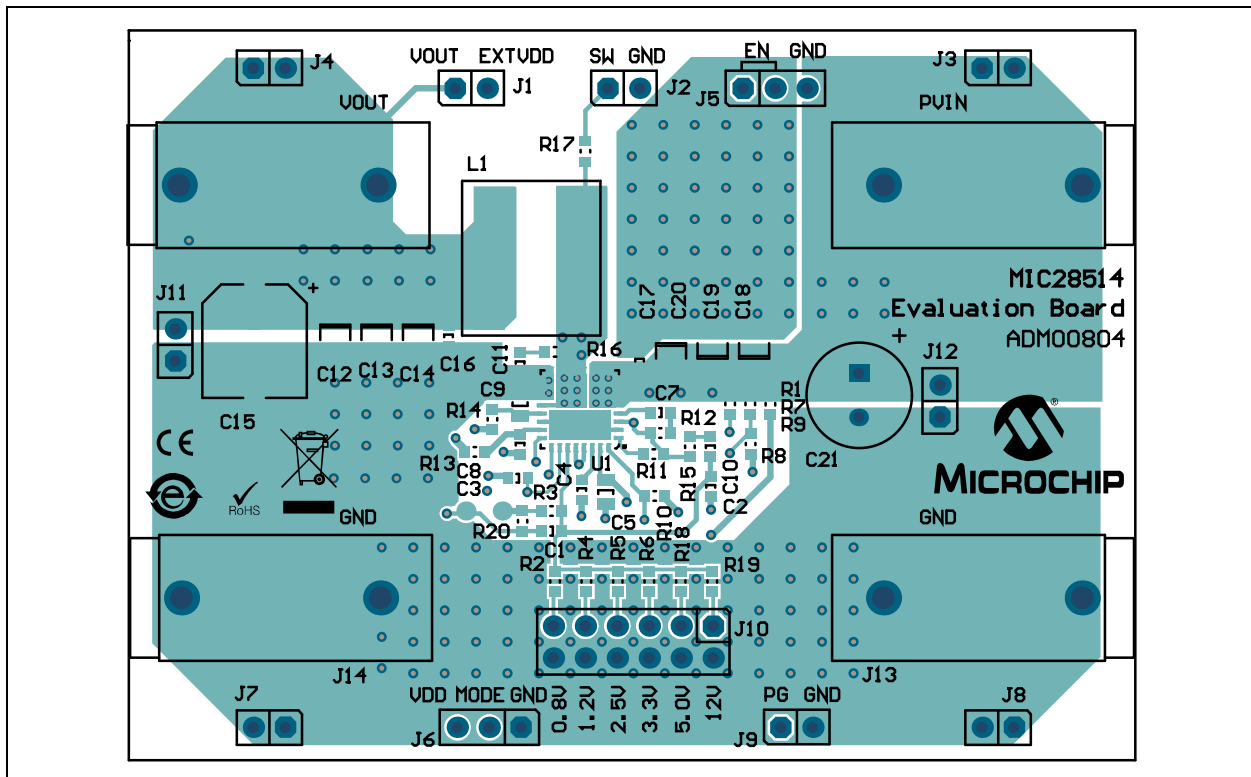

MIC28514 Evaluation Board User's Guide

A.5 BOARD – TOP COPPER

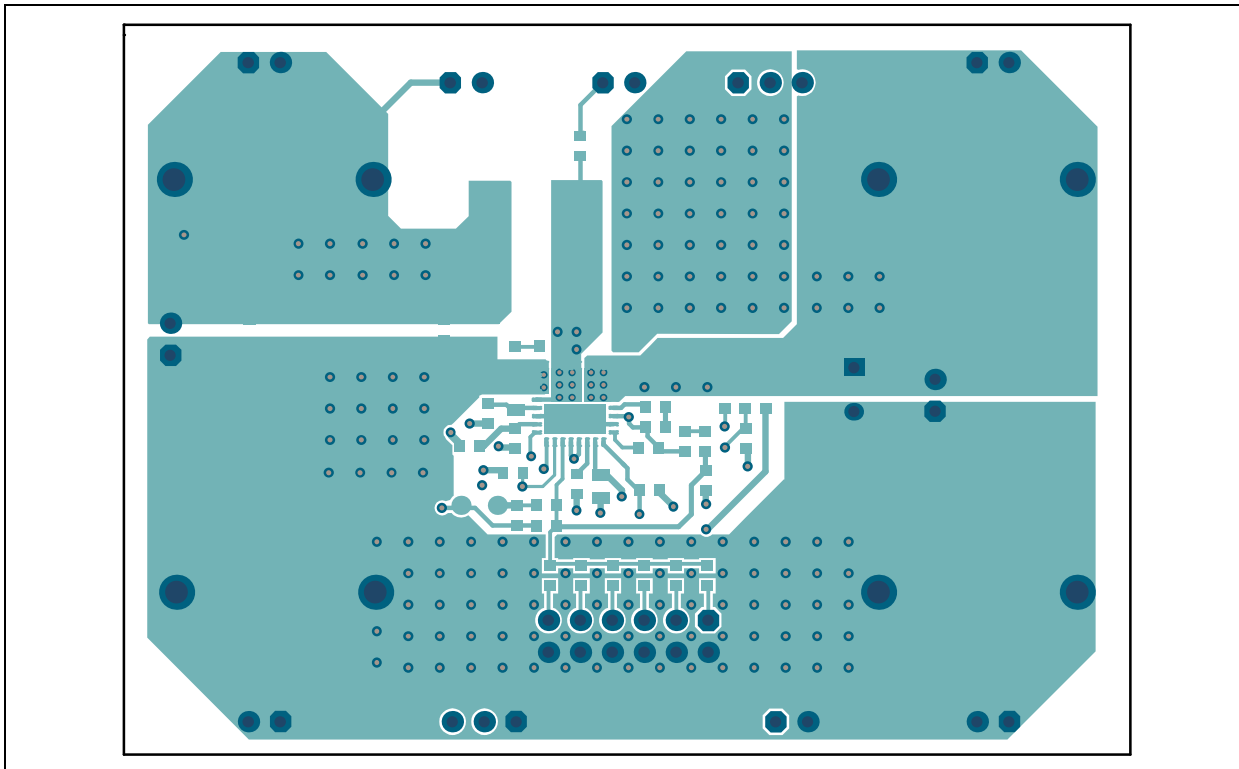

A.6 BOARD – MID COPPER LAYER 1

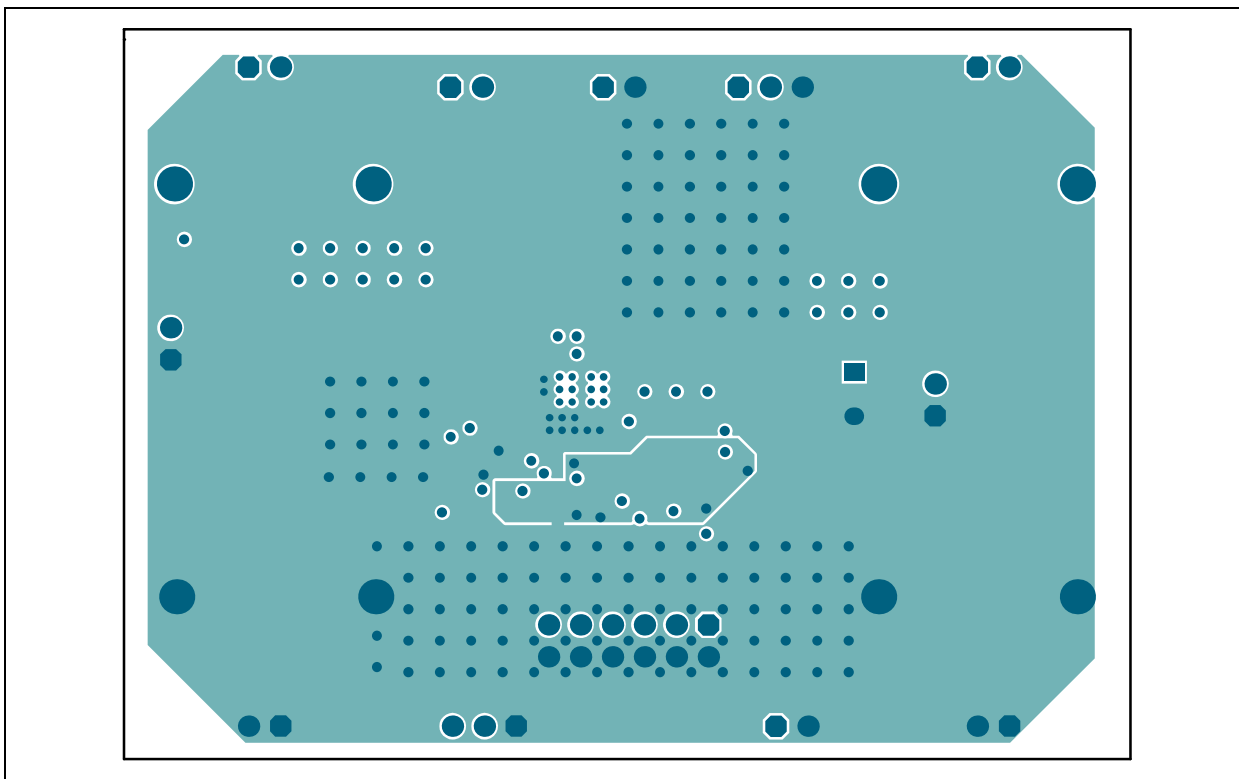

A.7 BOARD – MID COPPER LAYER 2

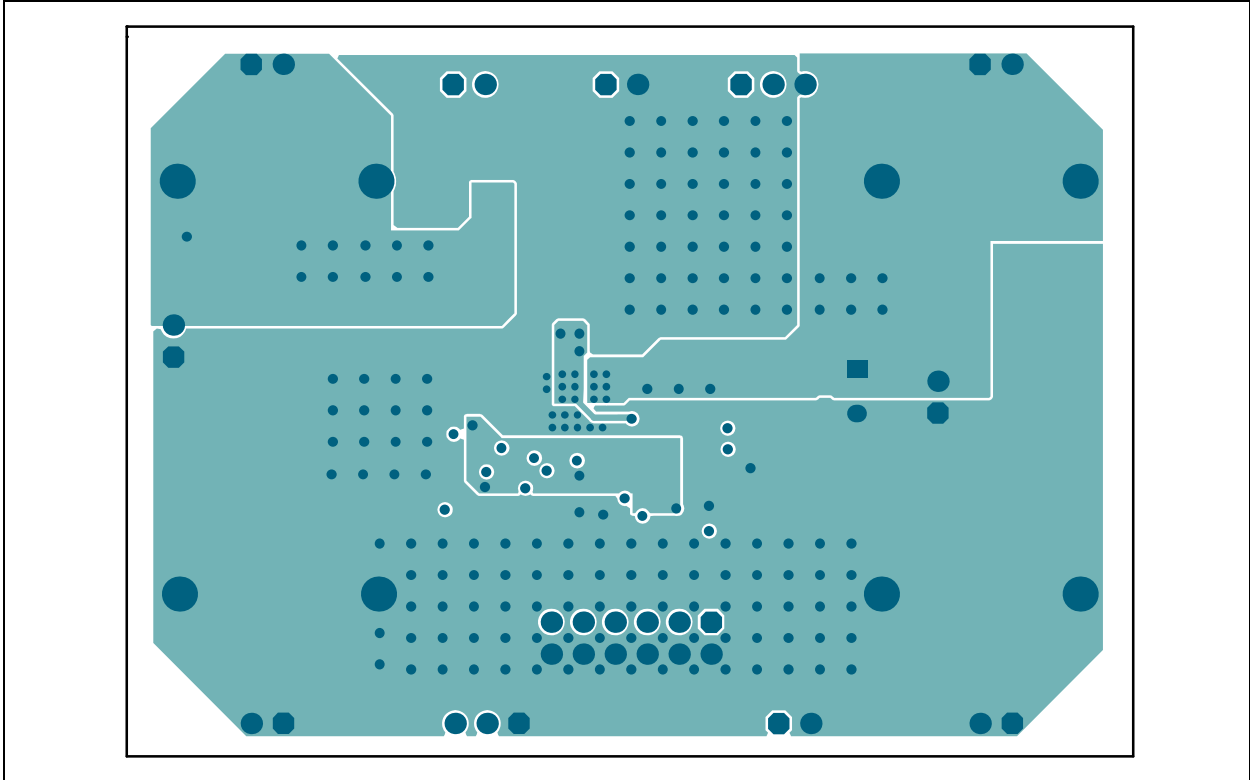

A.8 BOARD – BOTTOM COPPER

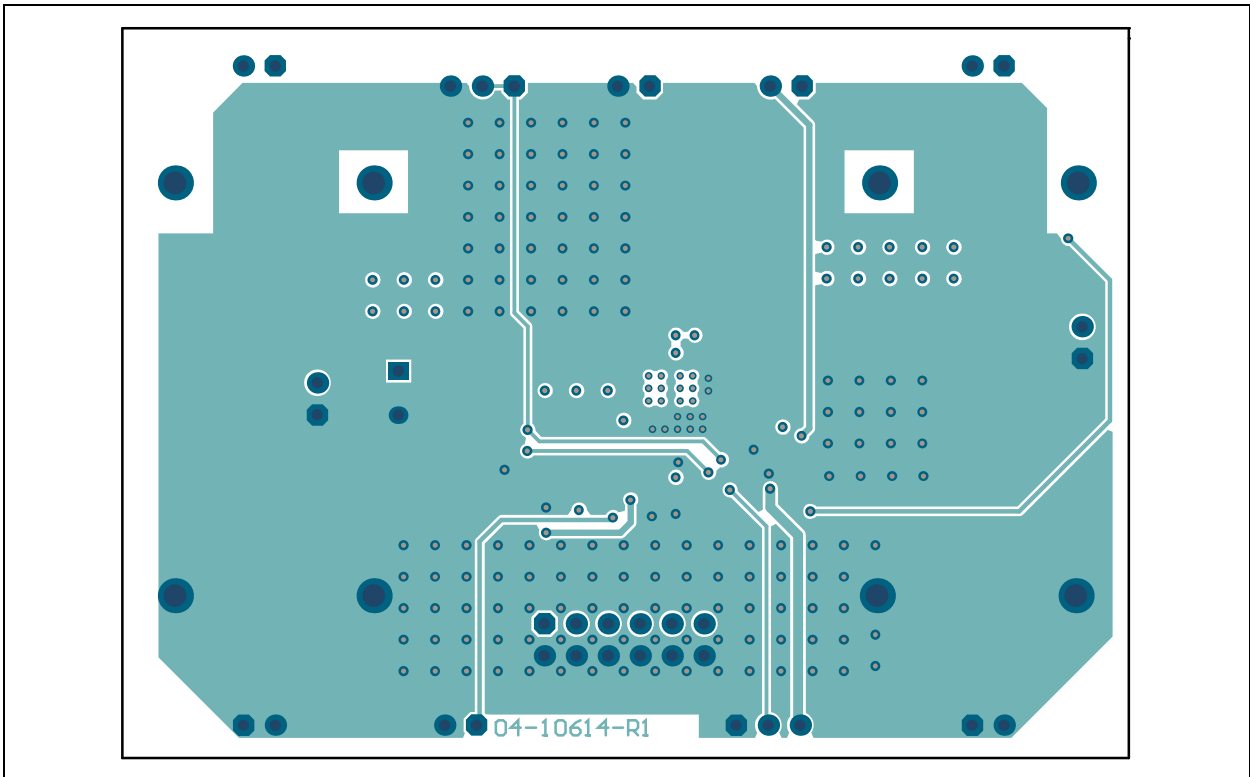

MIC28514 Evaluation Board User's Guide

A.9 BOARD – BOTTOM COPPER AND SILK

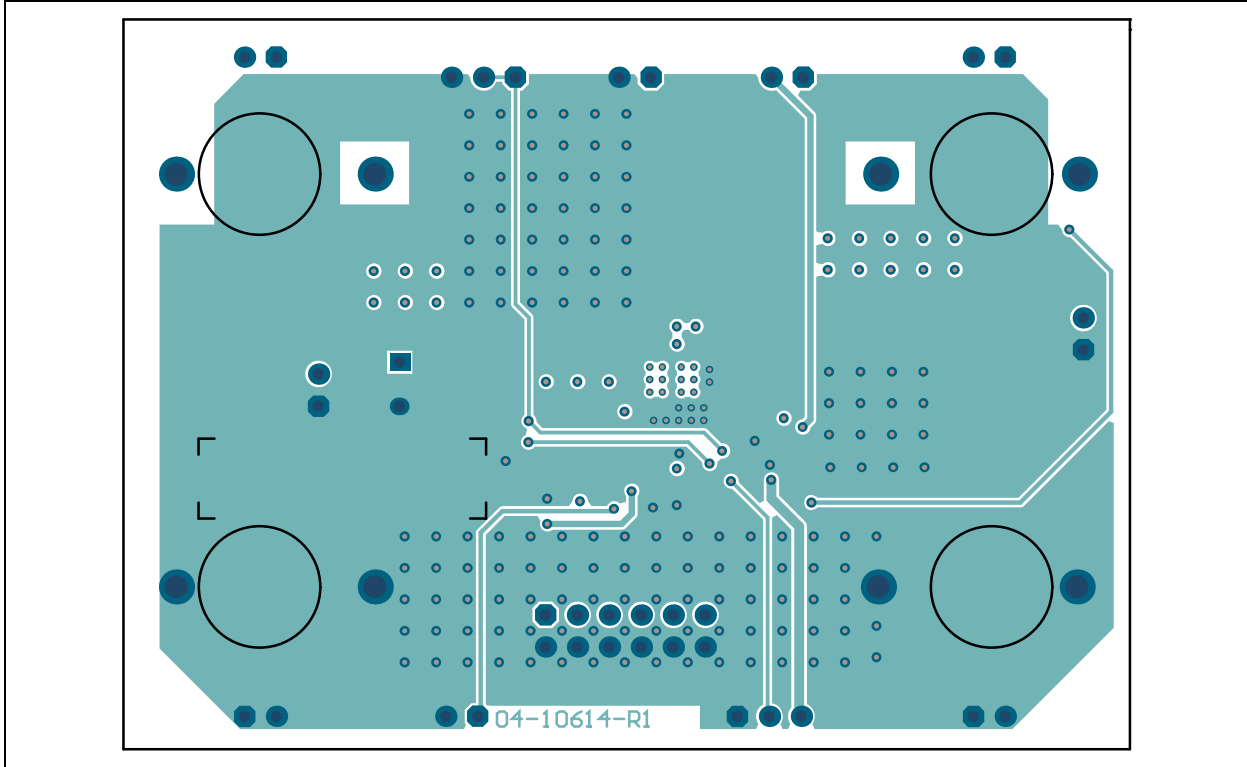

Appendix B. Bill of Materials (BOM)
TABLE B-1: BILL OF MATERIALS (BOM)

Qty.	Reference	Description	Manufacturer	Part Number
1	C1	Capacitor Ceramic, 4700 pF, 50V, 10%, X7R, SMD, 0603	KEMET	C0603C472K5RACTU
1	C2	Do Not Populate – Capacitor Ceramic, 10 pF, 50V, 0.5 pF, C0G, SMD, 0603	TDK Corporation	C1608C0G1H100D
1	C3	Capacitor Ceramic, 0.010 μ F, 25V, 10%, X7R, SMD, 0603	Yageo Corporation	CC0603KRX7R8BB103
2	C4, C8	Capacitor Ceramic, 2.2 μ F, 16V, 10%, X5R, SMD, 0603	TDK Corporation	C1608X5R1C225K
1	C5	Capacitor Ceramic, 1 μ F, 100V, 10%, X7S, SMD, 0805	TDK Corporation	C2012X7S2A105K125AB
3	C7, C10, C17	Capacitor Ceramic, 0.1 μ F, 100V, 10%, X7R, SMD, 0603	Murata Electronics North America, Inc.	GRM188R72A104KA35D
1	C9	Capacitor Ceramic, 4.7 μ F, 25V, 20%, X5R, SMD, 0805	TDK Corporation	C2012X5R1E475M125AB
1	C11	Do Not Populate – Capacitor Ceramic, 1000 pF, 50V, 20%, X7R, SMD, 0603	TDK Corporation	C1608X7R2A102K080AA
3	C12, C13, C14	Capacitor Ceramic, 47 μ F, 16V, 20%, X5R, SMD, 1210	Yageo Corporation	CC1210MKX5R7BB476
1	C15	Capacitor Aluminum, 330 μ F, 25V, 20%, SMD, F	Nichicon Corporation	UWT1E331MNL1GS
1	C16	Capacitor Ceramic, 0.1 μ F, 16V, 10%, X7R, SMD, 0603	AVX Corporation	0603YC104KAT2A
3	C18, C19, C20	Capacitor Ceramic, 2.2 μ F, 100V, 10%, X7R, SMD, 1210	KEMET	C1210C225K1RACTU
1	C21	Capacitor Aluminum, 39 μ F, 100V, 20%, RAD, P3.5D8H15	United Chemi-Con	EKZE101ELL390MH15D
9	J1, J2, J3, J4, J7, J8, J9, J11, J12	Connector Header-2.54 Male, 1x2, Gold, 5.84MH, TH, Vertical	FCI	77311-118-02LF
2	J5, J6	Connector Header-2.54 Male, 1x3, Gold, 5.84MH, TH, Vertical	FCI	68000-103HLF
1	J10	Connector Header-2.54 Male, 2x6, Gold, 5.84MH, TH, Vertical	Samtec, Inc.	TSW-106-07-G-D
2	J13, J14	Connector Jack Banana Blue Female, 4.0 mm, TH, R/A	Multicomp Inc.	24.243.5
1	L1	Inductor, 8.2 μ H, 17.1A, 20%, SMD, L11.3W10H10	Coilcraft	XAL1010-822MEB
1	PCB1	Printed Circuit Board	Microchip Technology Inc.	04-10614-R1

Note 1: The components listed in this Bill of Materials are representative of the PCB assembly. The released BOM used in manufacturing uses all RoHS-compliant components.

MIC28514 Evaluation Board User's Guide

TABLE B-1: BILL OF MATERIALS (BOM) (CONTINUED)

Qty.	Reference	Description	Manufacturer	Part Number
2	PV _{IN} , V _{OUT}	Connector Jack Banana Red Female, 4.0 mm, TH, R/A	Multicomp Inc.	24.243.1

Note 1: The components listed in this Bill of Materials are representative of the PCB assembly. The released BOM used in manufacturing uses all RoHS-compliant components.

Bill of Materials (BOM)

TABLE B-1: BILL OF MATERIALS (BOM) (CONTINUED)

Qty.	Reference	Description	Manufacturer	Part Number
1	R1	Resistor, TKF, 100k, 5%, 1/10W, SMD, 0603	Panasonic® - ECG	ERJ-3GEYJ104V
1	R2	Resistor, TKF, 30k, 1%, 1/10W, SMD, 0603	Stackpole Electronics, Inc.	RMCF0603FT30K0
4	R3, R4, R8, R10	Resistor, TKF, 10k, 1%, 1/8W, SMD, 0603	Vishay Beyschlag	MCT06030C1002FP500
1	R5	Resistor, TKF, 3.16k, 1%, 1/10W, SMD, 0603	Panasonic® - ECG	ERJ-3EKF3161V
1	R6	Resistor, TKF, 2.2k, 1%, 1/10W, SMD, 0603	Panasonic® - ECG	ERJ-3EKF2201V
1	R7	Resistor, TKF, 20k, 1%, 1/10W, SMD, 0603	Panasonic® - ECG	ERJ-3EKF2002V
1	R9	Resistor, TKF, 2R, 1%, 1/4W, SMD, 0603	Vishay/Dale	CRCW06032R00FKEAHP
1	R11	Resistor, TKF, 2.1k, 1%, 1/10W, SMD, 0603	Panasonic® - ECG	ERJ-3EKF2101V
1	R12	Resistor, TKF, 0R, 1/10W, SMD, 0603	Panasonic® - ECG	ERJ-3GSY0R00V
2	R13, R14	Resistor, TKF, 1R, 1%, 1/10W, SMD, 0603	Yageo Corporation	RC0603FR-071RL
1	R15	Resistor, TKF, 16.2k, 1%, 1/10W, SMD, 0603	Panasonic® - ECG	ERJ-3EKF1622V
1	R16	Do Not Populate – Resistor, TKF, 1R, 1%, 1/10W, SMD, 0603	Yageo Corporation	RC0603FR-071RL
1	R17	Resistor, TKF, 49.9R, 1%, 1/10W, SMD, 0603	Panasonic® - ECG	ERJ-3EKF49R9V
1	R18	Resistor, TKF, 1.37k, 1%, 1/10W, SMD, 0603	Yageo Corporation	RC0603FR-071K37L
1	R19	Resistor, TKF, 523R, 1%, 1/10W, SMD, 0603	Panasonic® - ECG	ERJ-3EKF5230V
1	R20	Resistor, TKF, 15R, 1%, 1/16W, SMD, 0603	Stackpole Electronics, Inc.	RMCF0603FT15R0
1	U1	MCHP Analog Switcher, Buck, 0.6V to 32V, MIC28514T-E/PHA VQFN-32	Microchip Technology Inc.	MIC28514T-E/PHA

Note 1: The components listed in this Bill of Materials are representative of the PCB assembly. The released BOM used in manufacturing uses all RoHS-compliant components.

TABLE B-2: BILL OF MATERIALS (BOM) – MECHANICAL PARTS

Qty.	Reference	Description	Manufacturer	Part Number
1	JP1	Mechanical Hardware Jumper, 2.54 mm, 1x2, Handle Gold	TE Connectivity, Ltd.	881545-2
1	LABEL1	Label, Assembly w/Rev. Level (Small Modules) per MTS-0002		
4	PAD1, PAD2, PAD3, PAD4	Mechanical Hardware, Rubber Pad, Cylindrical, D9.53H5.97	3M	SJ61A2

Note 1: The components listed in this Bill of Materials are representative of the PCB assembly. The released BOM used in manufacturing uses all RoHS-compliant components.

® MIC28514 Evaluation Board User's Guide

NOTES:



MICROCHIP

Worldwide Sales and Service

AMERICAS

Corporate Office
2355 West Chandler Blvd.
Chandler, AZ 85224-6199
Tel: 480-792-7200
Fax: 480-792-7277
Technical Support:
<http://www.microchip.com/support>
Web Address:
www.microchip.com

Atlanta
Duluth, GA
Tel: 678-957-9614
Fax: 678-957-1455

Austin, TX
Tel: 512-257-3370

Boston
Westborough, MA
Tel: 774-760-0087
Fax: 774-760-0088

Chicago
Itasca, IL
Tel: 630-285-0071
Fax: 630-285-0075

Dallas
Addison, TX
Tel: 972-818-7423
Fax: 972-818-2924

Detroit
Novi, MI
Tel: 248-848-4000

Houston, TX
Tel: 281-894-5983

Indianapolis
Noblesville, IN
Tel: 317-773-8323
Fax: 317-773-5453
Tel: 317-536-2380

Los Angeles
Mission Viejo, CA
Tel: 949-462-9523
Fax: 949-462-9608
Tel: 951-273-7800

Raleigh, NC
Tel: 919-844-7510

New York, NY
Tel: 631-435-6000

San Jose, CA
Tel: 408-735-9110
Tel: 408-436-4270

Canada - Toronto
Tel: 905-695-1980
Fax: 905-695-2078

ASIA/PACIFIC

Asia Pacific Office
Suites 3707-14, 37th Floor
Tower 6, The Gateway
Harbour City, Kowloon

Hong Kong
Tel: 852-2943-5100
Fax: 852-2401-3431

Australia - Sydney
Tel: 61-2-9868-6733
Fax: 61-2-9868-6755

China - Beijing
Tel: 86-10-8569-7000
Fax: 86-10-8528-2104

China - Chengdu
Tel: 86-28-8665-5511
Fax: 86-28-8665-7889

China - Chongqing
Tel: 86-23-8980-9588
Fax: 86-23-8980-9500

China - Dongguan
Tel: 86-769-8702-9880

China - Guangzhou
Tel: 86-20-8755-8029

China - Hangzhou
Tel: 86-571-8792-8115
Fax: 86-571-8792-8116

China - Hong Kong SAR
Tel: 852-2943-5100
Fax: 852-2401-3431

China - Nanjing
Tel: 86-25-8473-2460
Fax: 86-25-8473-2470

China - Qingdao
Tel: 86-532-8502-7355
Fax: 86-532-8502-7205

China - Shanghai
Tel: 86-21-3326-8000
Fax: 86-21-3326-8021

China - Shenyang
Tel: 86-24-2334-2829
Fax: 86-24-2334-2393

China - Shenzhen
Tel: 86-755-8864-2200
Fax: 86-755-8203-1760

China - Wuhan
Tel: 86-27-5980-5300
Fax: 86-27-5980-5118

China - Xian
Tel: 86-29-8833-7252
Fax: 86-29-8833-7256

ASIA/PACIFIC

China - Xiamen
Tel: 86-592-2388138
Fax: 86-592-2388130

China - Zhuhai
Tel: 86-756-3210040
Fax: 86-756-3210049

India - Bangalore
Tel: 91-80-3090-4444
Fax: 91-80-3090-4123

India - New Delhi
Tel: 91-11-4160-8631
Fax: 91-11-4160-8632

India - Pune
Tel: 91-20-3019-1500

Japan - Osaka
Tel: 81-6-6152-7160
Fax: 81-6-6152-9310

Japan - Tokyo
Tel: 81-3-6880-3770
Fax: 81-3-6880-3771

Korea - Daegu
Tel: 82-53-744-4301
Fax: 82-53-744-4302

Korea - Seoul
Tel: 82-2-554-7200
Fax: 82-2-558-5932 or
82-2-558-5934

Malaysia - Kuala Lumpur
Tel: 60-3-6201-9857
Fax: 60-3-6201-9859

Malaysia - Penang
Tel: 60-4-227-8870
Fax: 60-4-227-4068

Philippines - Manila
Tel: 63-2-634-9065
Fax: 63-2-634-9069

Singapore
Tel: 65-6334-8870
Fax: 65-6334-8850

Taiwan - Hsin Chu
Tel: 886-3-5778-366
Fax: 886-3-5770-955

Taiwan - Kaohsiung
Tel: 886-7-213-7830

Taiwan - Taipei
Tel: 886-2-2508-8600
Fax: 886-2-2508-0102

Thailand - Bangkok
Tel: 66-2-694-1351
Fax: 66-2-694-1350

EUROPE

Austria - Wels
Tel: 43-7242-2244-39
Fax: 43-7242-2244-393

Denmark - Copenhagen
Tel: 45-4450-2828
Fax: 45-4485-2829

Finland - Espoo
Tel: 358-9-4520-820

France - Paris
Tel: 33-1-69-53-63-20
Fax: 33-1-69-30-90-79

France - Saint Cloud
Tel: 33-1-30-60-70-00

Germany - Garching
Tel: 49-8931-9700

Germany - Haan
Tel: 49-2129-3766400

Germany - Heilbronn
Tel: 49-7131-67-3636

Germany - Karlsruhe
Tel: 49-721-625370

Germany - Munich
Tel: 49-89-627-144-0
Fax: 49-89-627-144-44

Germany - Rosenheim
Tel: 49-8031-354-560

Israel - Ra'anana
Tel: 972-9-744-7705

Italy - Milan
Tel: 39-0331-742611
Fax: 39-0331-466781

Italy - Padova
Tel: 39-049-7625286

Netherlands - Drunen
Tel: 31-416-690399
Fax: 31-416-690340

Norway - Trondheim
Tel: 47-7289-7561

Poland - Warsaw
Tel: 48-22-3325737

Romania - Bucharest
Tel: 40-21-407-87-50

Spain - Madrid
Tel: 34-91-708-08-90
Fax: 34-91-708-08-91

Sweden - Gothenberg
Tel: 46-31-704-60-40

Sweden - Stockholm
Tel: 46-8-5090-4654

UK - Wokingham
Tel: 44-118-921-5800
Fax: 44-118-921-5820