

This drawing involves proprietary design rights of Tyco Electronics Corporation, and all design, manufacture, reproduction, use and sale rights regarding the same are expressly reserved. It is submitted for a specific purpose and the recipient by accepting this drawing, assumes custody and control and agrees to take reasonable precautions; (a) that this drawing will not be copied and reproduced, in whole or in part, or its contents revealed in any manner, or to any person except to meet the purpose for which it was delivered and (b) that any special features peculiar to this design will not be incorporated in other projects without the expressed written permission of Tyco Electronics Corporation.

REVISIONS			
EC	REV	DESCRIPTION	DATE
CPR	A	NEW RELEASE	07/26/05

6. MODULE INFORMATION

CONNECTOR	TYCO PART NUMBER	CATALOG MODULE #	SIZE NO.	CONTACT QTY	MATING PIN	MAX. CURRENT (PER CONTACT)	CONTACT SPACING	VOLTAGE RATING*
PIN	1766705-1	FP711	8	5	1.25 X 7.00 [.049 X .276]	35 AMPERES	7.50 [L2953]	250 VOLTS
			22	24	.64 [L025] SQ.	3 AMPERES	2.50 [L0984]	125 VOLTS
			RIGHT ANGLE GUIDE SOCKET					

\*IAW IEC-950

NOTES: UNLESS OTHERWISE SPECIFIED.

- PART NUMBER CHANGES AND OR DESIGN CHANGES AFFECTING ITEM INTERCHANGEABILITY REQUIRE PRIOR ELCON APPROVAL AND AUTHORIZATION BY REVISION TO THIS DRAWING.
- MATERIALS:

INSULATORS: THERMOPLASTIC, GLASS REINFORCED, COLOR BLACK, UL94V-0 FLAMMABILITY RATED.

SOLDER SIGNAL PIN: BRASS ALLOY.

POWER CONTACTS: PHOSPHOR BRONZE ALLOY, COPPER ALLOY.

CROWN BANDS: BERYLLIUM COPPER ALLOY.

- FINISHES:



CONTACTS: GOLD PLATED PER MIL-G-45204 TYPE II, CLASS 0, .000030" MIN. THK, OVER NICKEL PER QQ-N-290, CLASS 2, .000040" MIN. THICKNESS.

TERMINALS: TIN PLATED, MATTE FINISH, .000100" MINIMUM THICKNESS.

- MOUNTING FLANGES ACCEPT M3 OR #4-40 SCREWS, (USER SUPPLIED).

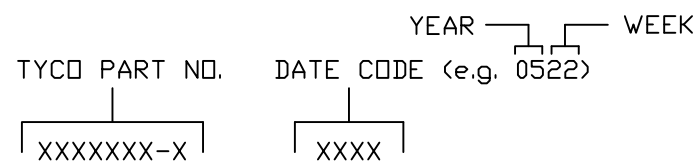
- ITEMS PROVIDED TO THIS SPECIFICATION TO BE PERMANENTLY IDENTIFIED PER THE FOLLOWING IDENTIFIER:

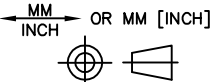

 THIRD ANGLE PROJECTION UNLESS OTHERWISE SPECIFIED DIMENSIONS ARE IN METRIC [INCHES] TOLERANCES ANGLES ± .5° DECIMALS .XX ± .25 [.010] .X ± .5 [.020]	DRAWN R. F. A.	DATE 07/22/05	 Tyco Electronics Corporation Menlo Park, Ca 94025 		
	CHECKED		TITLE CONNECTOR, PIN, RIGHT ANGLE STD SOLDER TAILS, FLATPAQ PN 1766705-1		
	APPROVED		SIZE B	DWG NUMBER C = 1766705	REV. A
	D. CHAU	08/03/05			
	DCA APPROVED M. ALIM	08/03/05			
ACAD FILE NUMBER		C1766705A.DWG	DWG SCALE 1=1		SH 1 OF 3

This drawing involves proprietary design rights of Tyco Electronics Corporation, and all design, manufacture, reproduction, use and sale rights regarding the same are expressly reserved. It is submitted for a specific purpose and the recipient by accepting this drawing, assumes custody and control and agrees to take reasonable precautions; (a) that this drawing will not be copied and reproduced, in whole or in part, or its contents revealed in any manner, or to any person except to meet the purpose for which it was delivered and (b) that any special features peculiar to this design will not be incorporated in other projects without the expressed written permission of Tyco Electronics Corporation.

REVISIONS

EC	REV	DESCRIPTION	DATE
		SEE SHEET 1	

B

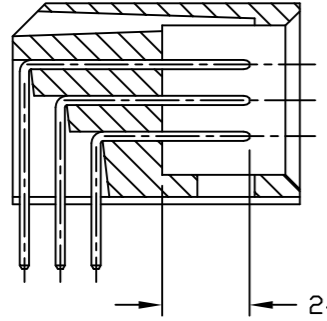
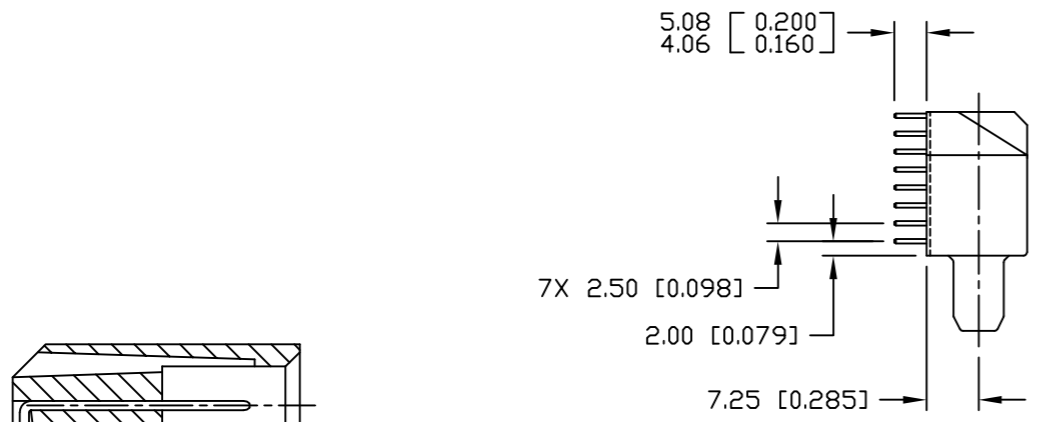

SECTION A-A

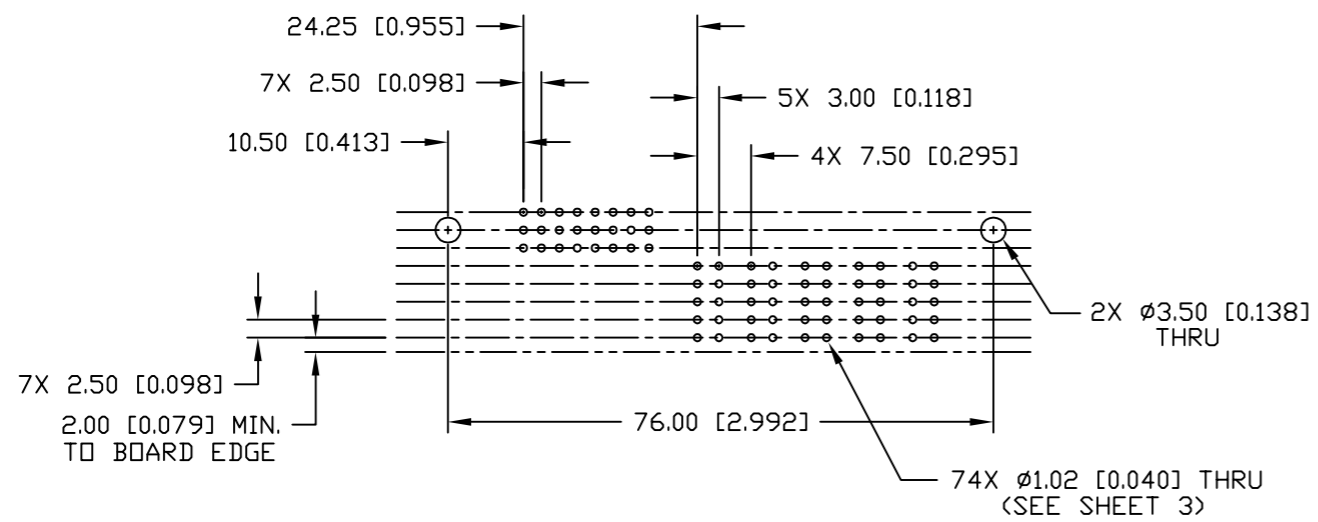
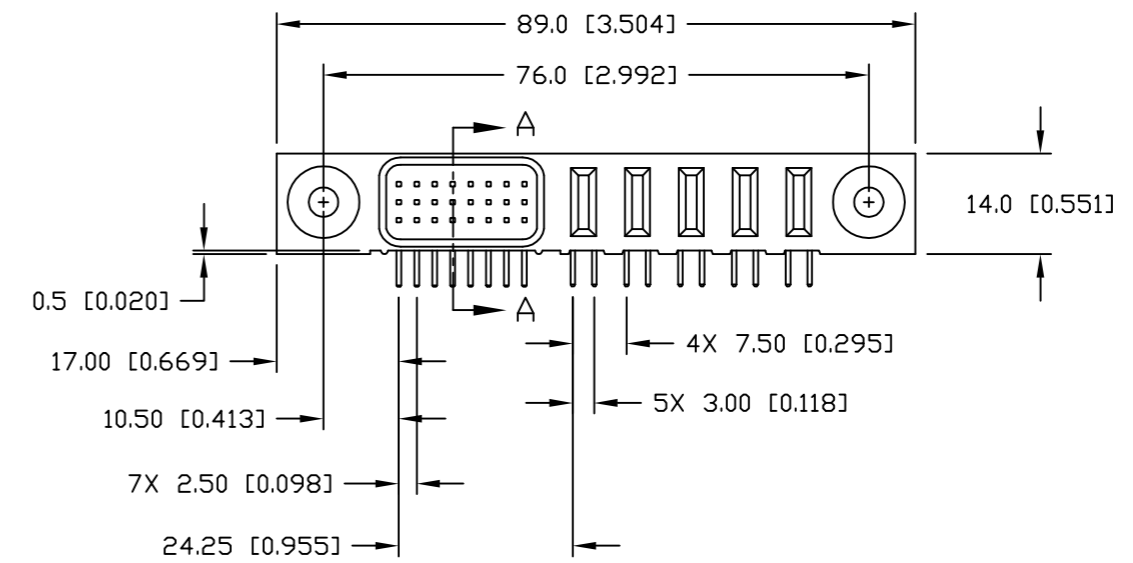
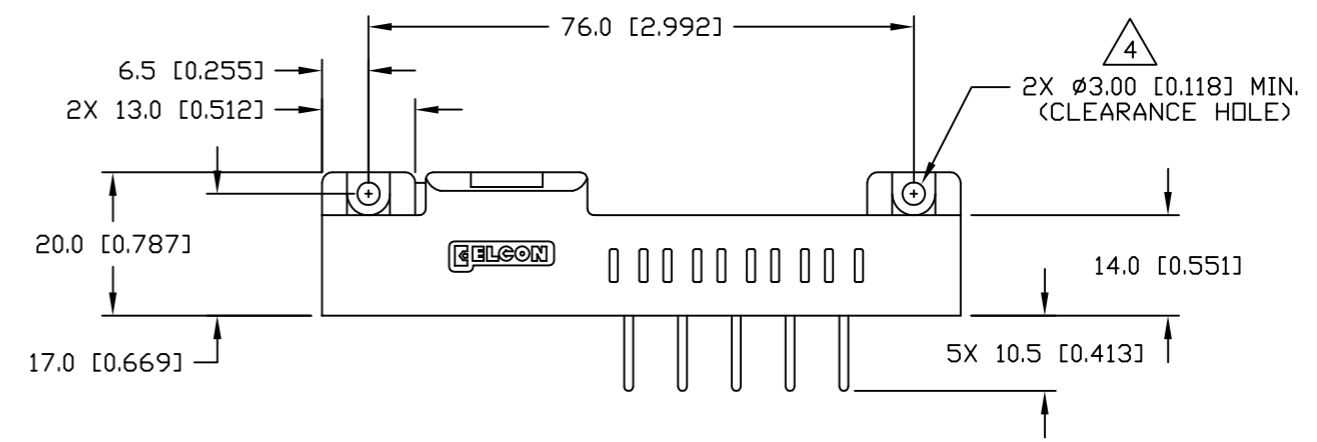

PRINTED CIRCUIT LAYOUT

A

A

← MM OR MM [INCH]  THIRD ANGLE PROJECTION UNLESS OTHERWISE SPECIFIED DIMENSIONS ARE IN METRIC [INCHES] TOLERANCES ANGLES ± .5° DECIMALS .XX ± .25 [.010] .X ± .5 [.020]	DRAWN R. F. A.	DATE 07/22/05	Tyco Electronics Corporation Menlo Park, Ca 94025 	
	CHECKED		TITLE	
	APPROVED		CONNECTOR, PIN, RIGHT ANGLE STD SOLDER TAILS, FLATPAQ PN 1766705-1	
	APPROVED D. CHAU	08/03/05	SIZE B	DWG NUMBER C = 1766705
	DCA APPROVED M. ALIM	08/03/05	DWG SCALE 1=1 SH 2 OF 3	
	ACAD FILE NUMBER	C1766705A.DWG		

4

3

2

1

This drawing involves proprietary design rights of Tyco Electronics Corporation, and all design, manufacture, reproduction, use and sale rights regarding the same are expressly reserved. It is submitted for a specific purpose and the recipient by accepting this drawing, assumes custody and control and agrees to take reasonable precautions; (a) that this drawing will not be copied and reproduced, in whole or in part, or its contents revealed in any manner, or to any person except to meet the purpose for which it was delivered and (b) that any special features peculiar to this design will not be incorporated in other projects without the expressed written permission of Tyco Electronics Corporation.

REVISIONS

EC	REV	DESCRIPTION	DATE
		SEE SHEET 1	

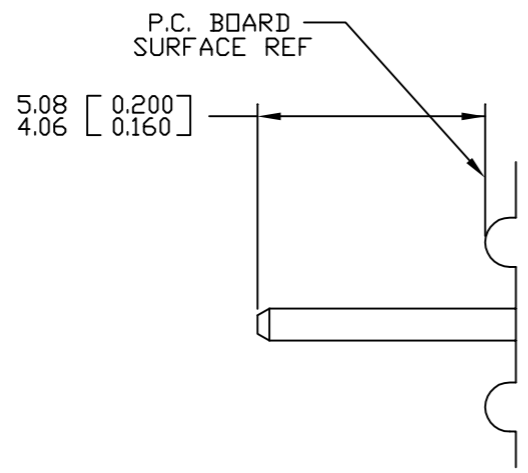

SOLDER PIN DETAIL

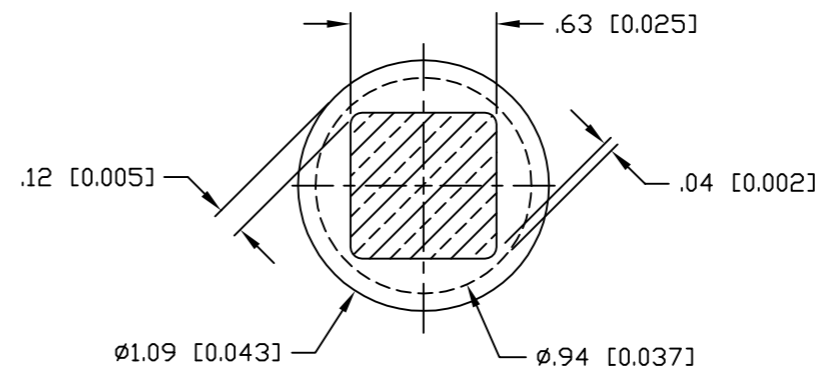

SOLDER TERMINATION AREA

RECOMMENDED PRINTED CIRCUIT HOLE

- FINISHED HOLE:  $\phi 1.02 [0.040] \pm .08 [0.003]$
- DRILLED HOLE:  $\phi 1.15 [0.0453] \pm .013 [0.0005]$
- COPPER PLATE: .025 [0.0010] MINIMUM (PER SURFACE)
- TIN PLATE: .008 [0.0003] MINIMUM (PER SURFACE)

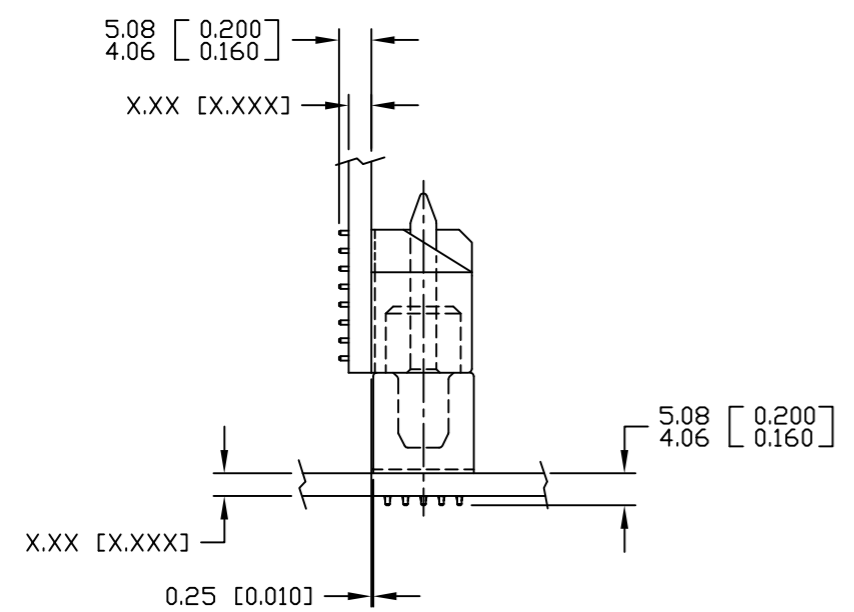

MATED CONDITION

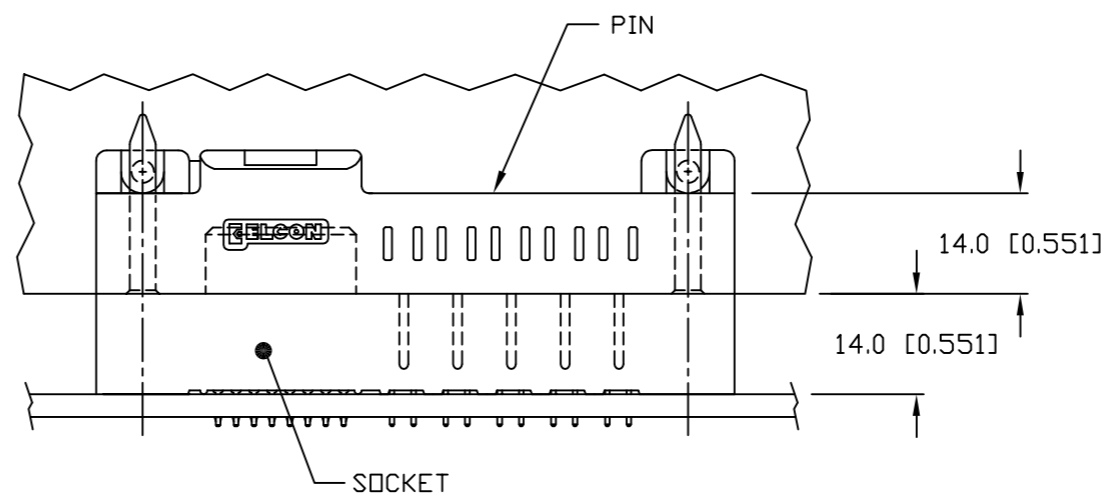

<p>← MM OR MM [INCH]</p> <p>THIRD ANGLE PROJECTION</p> <p>UNLESS OTHERWISE SPECIFIED DIMENSIONS ARE IN METRIC [INCHES]</p> <p>TOLERANCES</p> <p>ANGLES <math>\pm .5^\circ</math></p> <p>DECIMALS</p> <p>.XX <math>\pm .25 [0.010]</math></p> <p>.X <math>\pm .5 [0.020]</math></p>	<p>DRAWN</p> <p>R. F. A.</p>	<p>DATE</p> <p>07/22/05</p>	<p><b>tyco</b> Tyco Electronics Corporation <b>ELCON</b></p> <p>Menlo Park, Ca 94025</p>		
	<p>CHECKED</p>		<p>TITLE</p> <p>USER INFORMATION</p> <p>SOLDER TAIL TERMINATION</p> <p>AND MATED CONDITION</p>		
	<p>APPROVED</p>		<p>APPROVED</p> <p>D. CHAU</p> <p>08/03/05</p>	<p>APPROVED</p> <p>M. ALIM</p> <p>08/03/05</p>	<p>SIZE</p> <p>B</p>
	<p>ACAD FILE NUMBER</p> <p>C1766705A.DWG</p>	<p>DWG NUMBER</p> <p>C = 1766705</p>	<p>REV.</p> <p>A</p>	<p>DWG SCALE</p> <p>1 = 1</p>	<p>SH 3 OF 3</p>