

WALL MOUNT FOOT

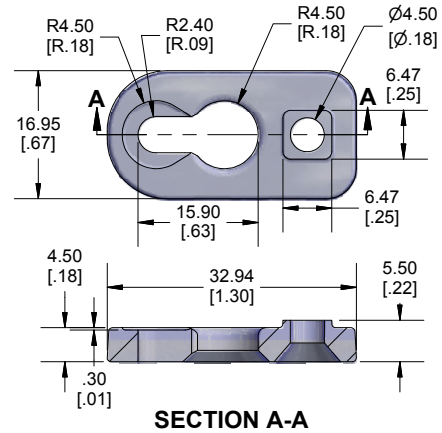

SECTION A-A

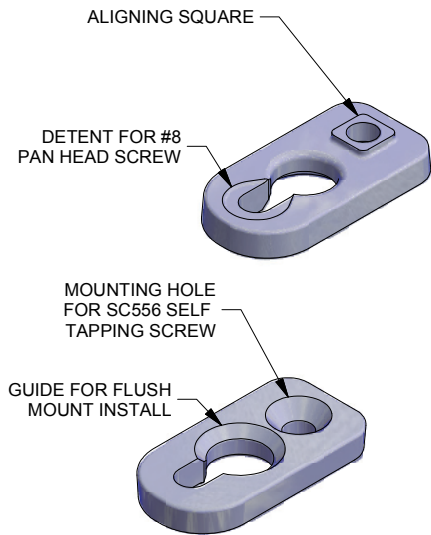
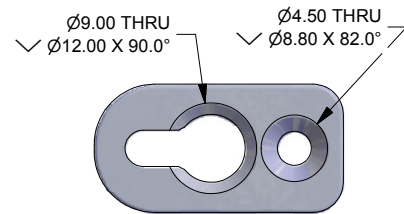

FLUSH MOUNT INSTALLATION

1. At the correct spacing for your enclosure, we recommend installing two #8 pan head screw (not included),
2. Using a mounting foot, set the height for the screw by loosely tightening the screw onto the foot. Remove foot and give the screw 1/4 turn more.

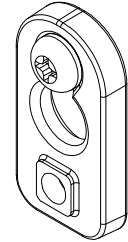
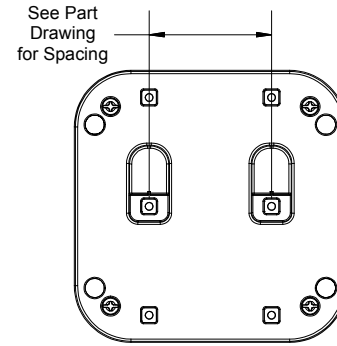

3. Install mounting feet to enclosure, using supplied screws with a torque of **Polycarbonate 100 - 110 cN-m or 8.8 - 9.7 lbf-in. ABS 80 - 90 cN-m or 7 - 8 lbf-in.**
4. Push enclosure onto installed screws. Press down on top of the enclosure till you feel the detent click over the pan head screw. some adjustment may be required.

HEAVY DUTY MOUNT INSTALLATION

1. Install mounting feet to enclosure, using supplied screws with a torque of **Polycarbonate 100 - 110 cN-m or 8.8 - 9.7 lbf-in. ABS 80 - 90 cN-m or 7 - 8 lbf-in.**
2. Mount enclosure to object. Recommend using #8 pan head screws (not included).

