

DESCRIPTION

The IF-E91A is a high-output medium-speed infrared LED in a “connector-less” style plastic fiber optic package. The output spectrum peaks at 930 nm for the IF-E91A. The device package features an internal micro-lens, and a precision-molded PBT housing ensures efficient optical coupling with standard 1000 μm plastic fiber cable.

APPLICATION HIGHLIGHTS

The high output and fast transition times of the IF-E91A are suitable for low-cost analog and digital data links. Used with an IF-D96 photologic detector, the IF-E91A can achieve data rates of 500 kbps at link distances up to 7 m. The drive circuit design is simpler than required for laser diodes, making the IF-E91A an excellent low-cost alternative in a variety of analog and digital applications.

APPLICATIONS

- Low Cost Analog and Digital Data Links
- Digitized Audio
- Optical Sensors
- Medical Instruments
- Robotics Communications
- Motor Controller Triggering
- EMC/EMI Signal Isolation
- Electronic Games
- Intra-System Links: Board-to-Board, Rack-to-Rack

FEATURES

- ◆ Excellent Linearity
- ◆ No Optical Design Required
- ◆ Mates with Standard 1000 μm Core, 2.2 mm Jacketed Plastic Fiber Cable
- ◆ Mates with 2.2 mm Jacketed Multimode Glass Fiber, 200/230 or 400/430 using Active Device Adapter – 51 0537; 51 0538
- ◆ Internal Micro-Lens for Efficient Coupling
- ◆ Inexpensive Plastic Connector Housing
- ◆ Connector-Less Fiber Termination and Connection
- ◆ Interference-Free Transmission from Light-Tight Housing
- ◆ RoHS Compliant

MAXIMUM RATINGS

(T_A =25°C)

Operating and Storage Temperature Range (T_{OP}, T_{STG}).....-40°to 85°C
 Junction Temperature (T_J).....85°C
 Soldering Temperature (2 mm from case bottom) (T_S)t ≤ 5 s.....260°C
 Reverse Voltage (V_R).....5 V
 Power Dissipation (P_{TOT}) T_A =25°C.....80 mW
 De-rate Above 25°C.....1.33 mW/°C
 Forward Current, DC (I_F)50 mA
 Surge Current (I_{FSM}) t ≤ 10 μsec duty cycle <1%.....1.2 A

CHARACTERISTICS (T_A =25°C)

Parameter	Symbol	Min.	Typ.	Max.	Unit
Peak Wavelength	λ _{PEAK}	–	930	–	nm
Spectral Bandwidth (FWHM)	Δλ	–	50	–	nm
Output Power Coupled into Plastic Fiber (1 mm core diameter). Distance Lens to Fiber ≤ 0.1 mm, 1 m SH4001 fiber, I _F =20 mA	P _O	50 -13	70 -11.6	95 -10.2	μW dBm
Output Power Coupled into Glass Fiber (200/230 μm core) Distance Lens to Fiber ≤0.1 mm, 1 meter BC04265-10 fiber, I _F =20 mA	P _O	–	18.11 -17.42	–	μW dBm
Fiber Transmission Loss SH4001 10 meter cutback	L	–	3.2	–	dB/m
Switching Times (10% to 90% and 90% to 10%) (Figure 3)	t _r , t _f	–	0.7	–	μs
Capacitance (F=1 MHz)	C ₀	–	20	–	pF
Forward Voltage (I _F =20 mA) (I _F =50 mA)	V _f	–	1.2 1.27	1.6 1.6	V

CAUTION: The IF E91A is ESD sensitive. To minimize risk of damage observe appropriate precautions during handling and processing.

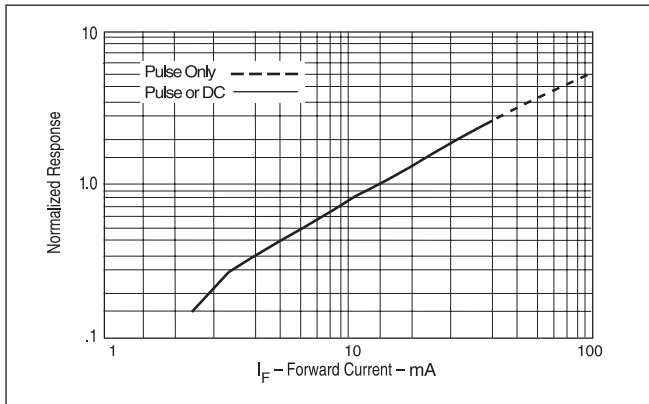

FIGURE 1. Normalized power launched versus forward current

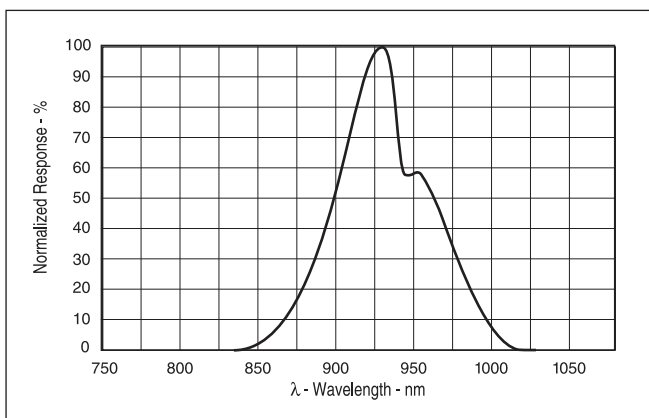

FIGURE 2. Typical spectral output versus wavelength.

APPLICATION NOTES

The application circuit given in Figure 3 can be used to drive the IF-E91A for fast applications. Gate U1 represents the circuit being used to drive the IF-E91A. This must be able to supply the desired drive current at the output voltage. Resistor R_A supplies most of the drive current for the IF-E91A. The amount of current supplied is $I_A = (V_{U1} - V_f) / R_A$, where V_f is the IF-E91A forward voltage and V_{U1} is the drive circuit's output voltage under load. Resistor R_B speeds up the switching time by keeping the voltage across the IF-E91A from going to zero during turn off. It also supplies some of the drive current. The drive current from R_B is $I_B = (V_{CC} - V_f) / R_B$, where V_{CC} is the supply voltage. The total drive current to the IF-E91A is $I_A + I_B$. Some power is wasted in R_B when the IF-E91A is off. Capacitor C_A is used to increase the drive current during switching and speed up the turn on and turn off times. It must not be so large as to overdrive the IF-E91A during turn on or drive the voltage negative during turn off. For lower speed applications, only R_A is needed and C_A and R_B can be omitted.

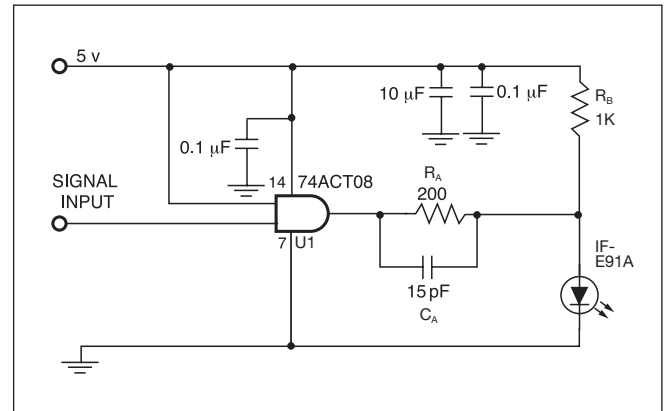

FIGURE 3. Test/Application circuit ($I_F = 22\text{mA}$).

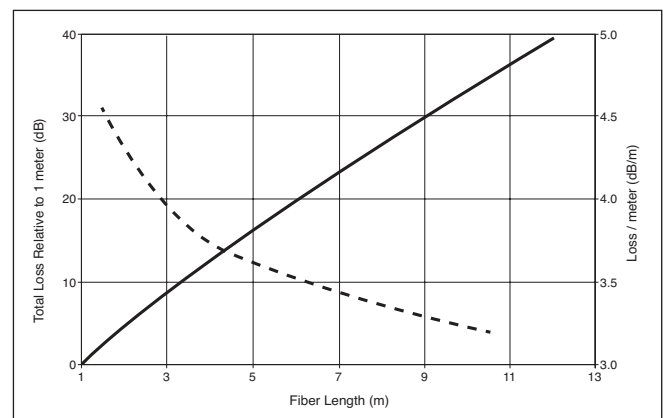

FIGURE 4. Fiber Loss in GH4001

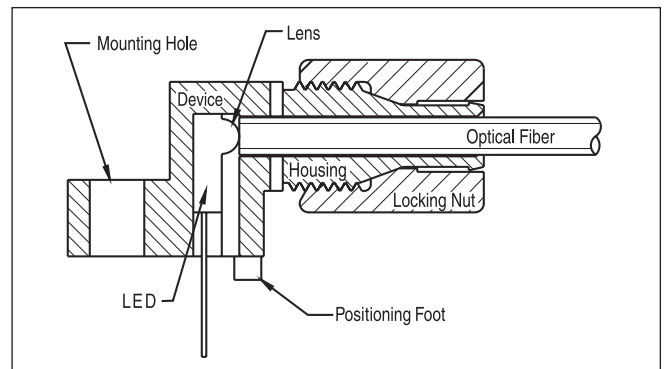

FIGURE 5. Cross-section of fiber optic device.

FIBER TERMINATION INSTRUCTIONS – PLASTIC OPTICAL FIBER

1. Cut off the ends of the optical fiber with a single-edge razor blade or sharp knife. Try to obtain a precise 90-degree angle (square).
2. Insert the fiber through the locking nut and into the connector until the core tip seats against the internal micro-lens.
3. Screw the connector locking nut down to a snug fit, locking the fiber in place. Do not exceed a torque of 0.4 N·m.

Glass fiber – Refer to instructions listed on manufacturer's data sheet for each active device adapter.

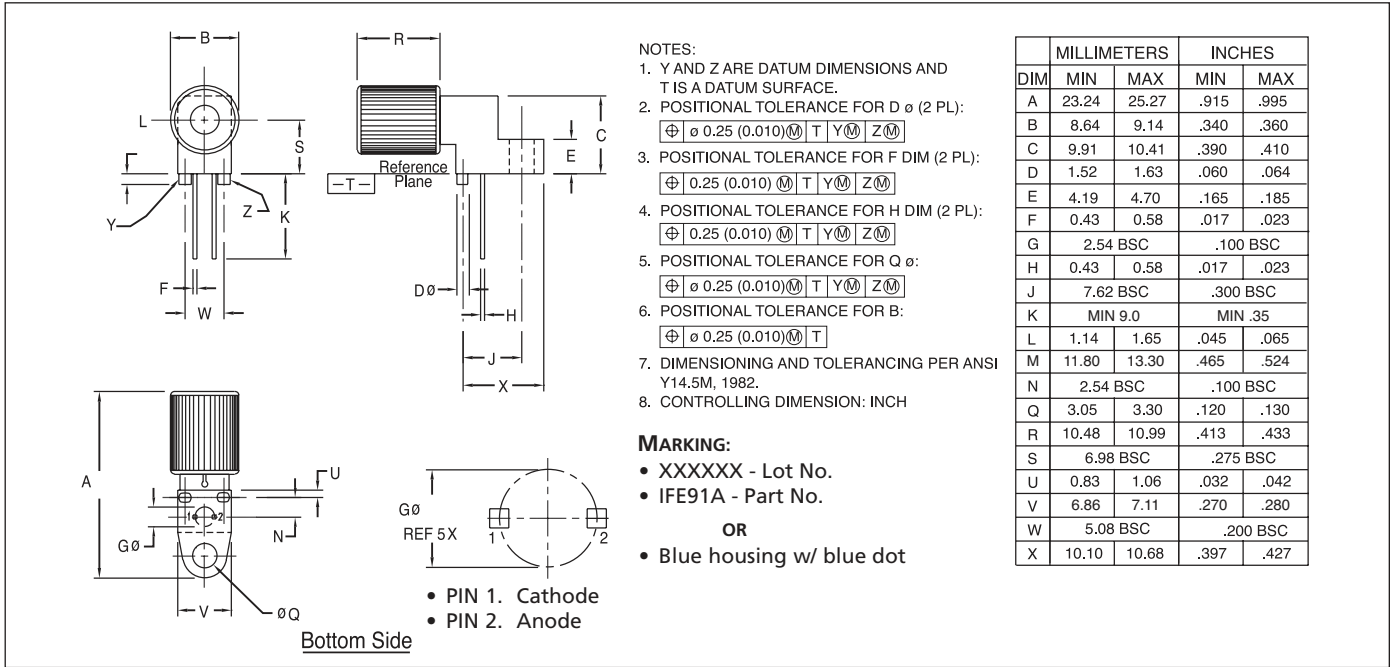

FIGURE 5. Case outline. Specifications are believed to be accurate but are subject to change. Industrial Fiber Optics assumes no responsibility for the consequences of using the information provided beyond replacement warranty for products not meeting stated specifications. Industrial Fiber Optics products are not authorized for use in life support applications without written approval from the President of Industrial Fiber Optics Corporation.

CAUTION:

- To avoid degraded device life due to package stress, do not bend or form leads outside the orientation shown on drawing.
- Ensure that solder flux does not migrate into the device and block the optical path, degrading the performance.
- If washing the device, liquid may become trapped in the part cavity. Ensure that all potentially corrosive materials are flushed out of the device.