

MOP-TFT480272-43A/G -IPS

Hardware Manual

Revision 1.0



Contents

Contents	1
1 Contact	2
2 Customization	2
3 General Information	3
4 Part Numbering	3
5 Dimensions	4
5.1 MOP-TFT480272-43A TPN & TPR	4
5.2 MOP-TFT480272-43A TPC	5
5.3 MOP-TFT480272-43G TPC	6
6 Electrical Characteristics	7
7 Backlight Characteristics	7
8 Touch Panel Characteristics	8
8.1 Resistive	8
8.2 Capacitive 43A Series	8
8.3 Capacitive 43G Series	8
9 Interface Description	9
9.1 40 pin RGB	9
9.2 Capacitive Touch	9
10 Interface Pixel Timing	10
11 Power Sequence	11
11.1 Power Up Sequence	11
11.2 Power Down Sequence	11
12 Environmental	11
13 Suggested Products	12
14 Inspection Criterion	12
15 Handling Precautions	13
16 Revision History	14

1 Contact



On Shore and In-House Design

In-House Manufacturing

In-House Sales

In-House Support

In Calgary, Canada

Sales

Phone: (403) 229-2737

Email: sales@matrixorbital.ca

Support

Phone: (403) 229-2737

Email: support@matrixorbital.ca

Online

Purchasing: www.matrixorbital.com

Support: www.matrixorbital.com

Free support forums

<https://www.lcdforums.com/forums>

Example Code on GitHub

<https://github.com/MatrixOrbital>

2 Customization

Need a custom solution? No problem! Since we manufacture our products in-house, we are highly flexible, have low MOQ's and provide you what you need. From custom headers to custom cables to entire custom displays, we can make what you need.



3 General Information

The MOP-TFT480272 is a 4.3" IPS Sunlight readable TFT.

Item	Contents	Unit
Display Size (Diagonal)	4.3"	inch
Display type	IPS TFT	
Resolution	480x272	Pixels
Display Mode	Transmissive, Normally Black	
Backlight	LED, 1000 cd/m ² , 50,000 hours	
View Direction	Free	
Gray Scale Inversion Direction	None	
Module Outline	105.5 (W) x 67.2 (H)	mm
Active Area	95.0 (W) x 53.7 (H)	mm
Pixel Pitch	0.198 (W) x 0.198 (H)	mm
Polarizer Surface Treatment	Anti-glare	
Display Colors	16.7M	
Interface	24-bit RGB interface	
Display Driver IC	SC7283-G4 or Equivalent	
Capacitive Touch IC	GT911 or Equivalent	
Operating Temperature	-20 to 70	°C
Storage Temperature	-30 to 80	°C

4 Part Numbering

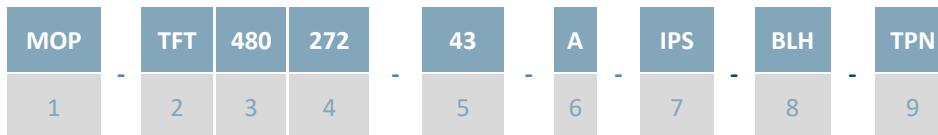

#	Designator	Options
1	Product Line	MOP: Matrix Orbital Parallel Display
2	Screen Type	TFT: Graphic TFT
3	Display Columns	480
4	Display Rows	272
5	Display Size	35: 3.5" 39: 3.9" 43: 4.3" 50: 5.0" 70: 7.0"
6	Display Form Factor	A: Standard TFT G: Extended Bezel capacitive touch panel
7	IPS Display	-IPS
8	Brightness Level	-BLM: 300 - 600 Nit -BLH: 600 - 1000 Nit -BLD: 1000+ Nit
9	Touch Panel Type	TPN: None TPR: Resistive TPC: Capacitive

5 Dimensions

5.1 MOP-TFT480272-43A TPN & TPR

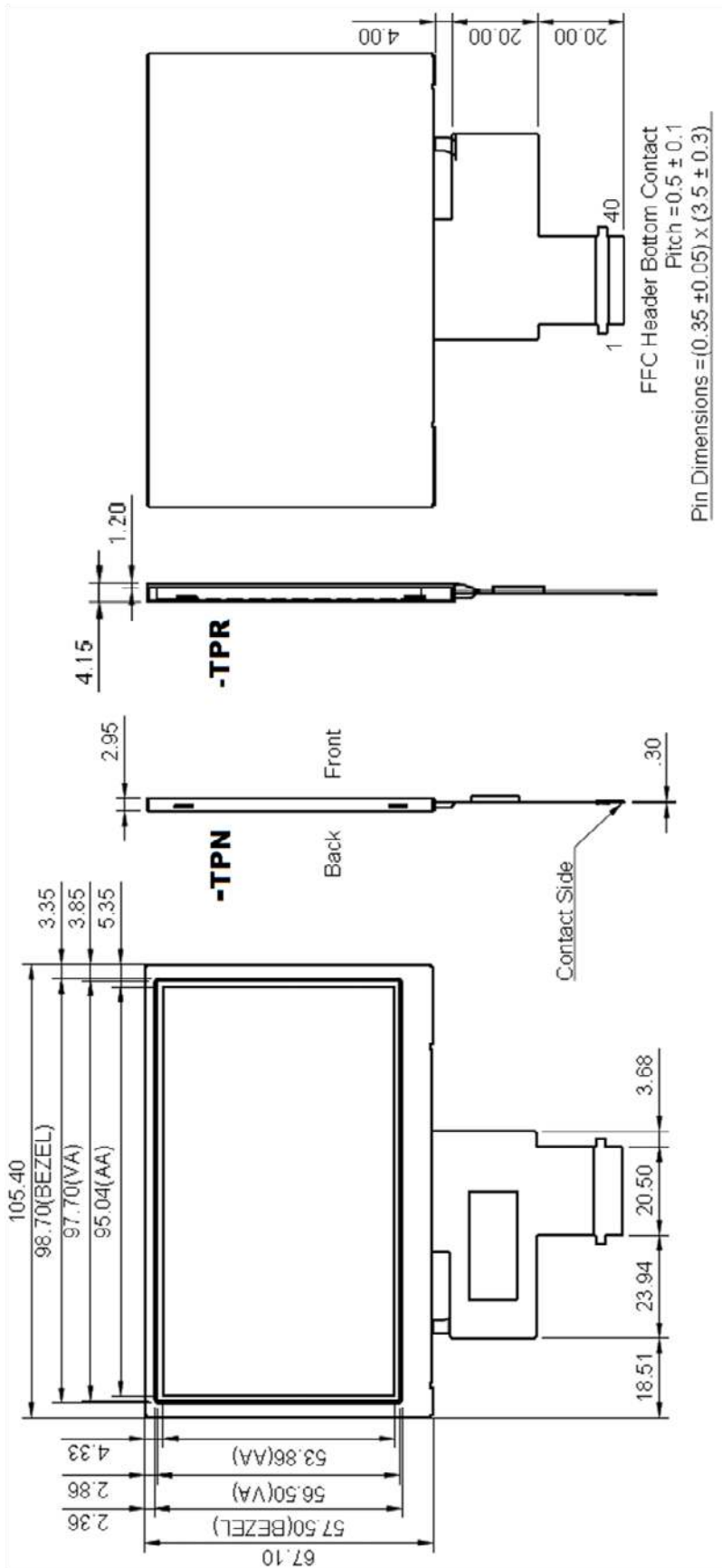

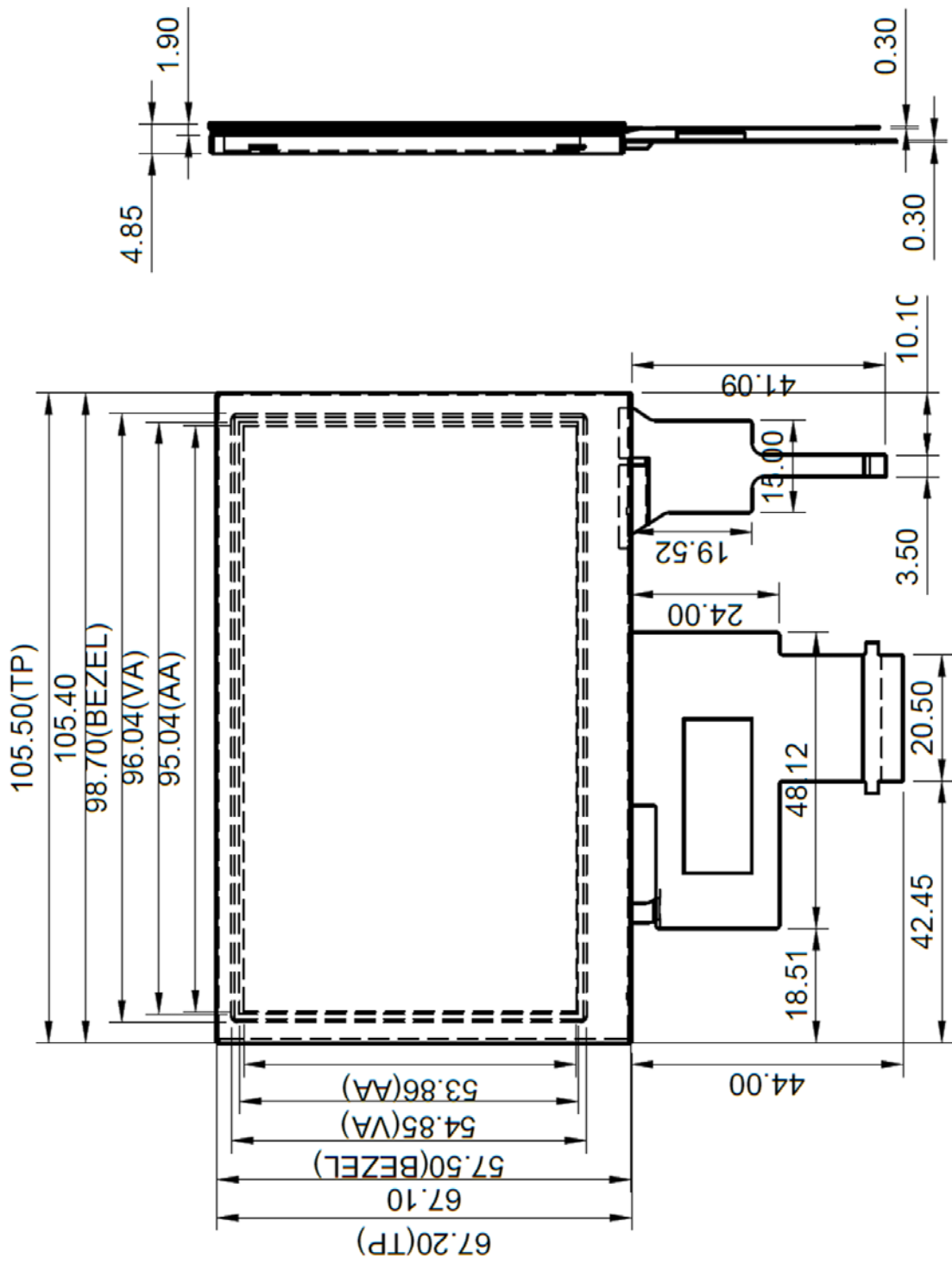

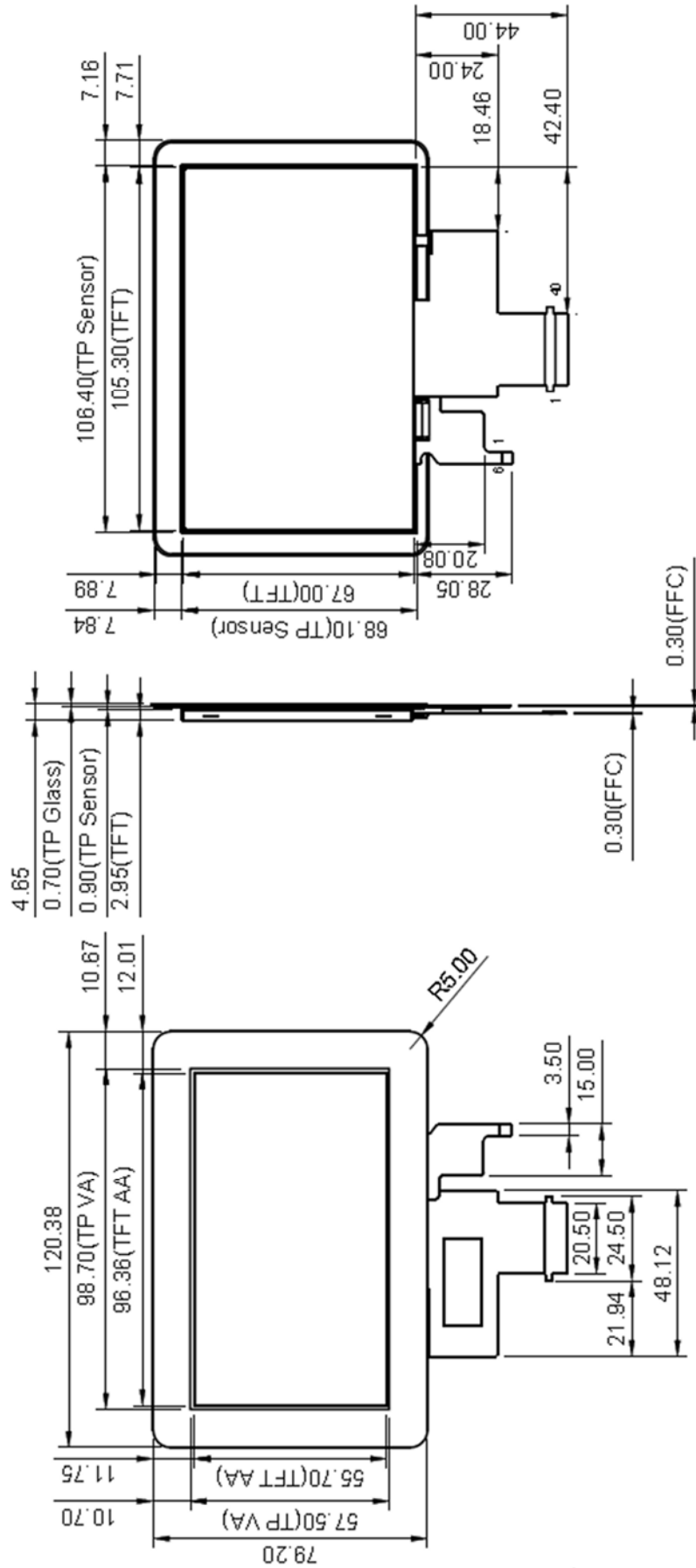

6 Electrical Characteristics

Item	Symbol	Min	Typ	Max	Unit	
Digital Interface Supply Voltage	VCC	3.0	3.3	3.6	V	
Logic Low input voltage	V _{IL}	GND	-	0.3*VCC	V	
Logic High input voltage	V _{IH}	0.7*VCC	-	VCC	V	
Logic Low output voltage	V _{OL}	GND	-	GND+0.4	V	
Logic High output voltage	V _{OH}	VCC-0.4	-	VCC	V	
Current Consumption All Black	Logic	I _{cc} +I _{in}	-	15	30	mA
	Analog					

7 Backlight Characteristics

Item	Symbol	Min.	Typ.	Max.	Unit
Forward Voltage	V _F	16.8	18.0	19.2	V
Forward Current	I _F	-	40	-	mA
Drive method	Constant current				
LED Configuration	12 White LEDs, 6 Serial x 2 Parallel				
Backlight life	Minimum: 20,000 hours Typical: 50,000 hours				

Values at 25°C, 60% RH, at 50k hours backlight will be at 50% brightness



Item	TPN	TPR	TPC	Unit
Luminance	1000	800	900	nit
Contrast Ratio	500	500	500	

8 Touch Panel Characteristics

Coordinate Origin: top left corner

Parameter	-TPR (resistive)	-TPC (capacitive)
IC	NA	GT911
Touch Points	1	5
Hardness	3H	6H

8.1 Resistive

Item		Typ.
Operation Force	60 – 100	grams
Resistance	X: 300 - 1000 Y: 100 - 450	Ohm

***Note:** Do not operate it with a thing except a polyacetal pen (tip R0.8mm or less) or a finger, especially those with hard or sharp tips such as a ball point pen or a mechanical pencil.

8.2 Capacitive 43A Series

For increased sensitivity through acrylic or glass please contact us.

Item	43A
IC	GT911
I2C Slave Address	0xBA/0xBB or 0x28/0x29 (8bit)
Speed	400Kbps
Durability	64g steel ball at 100cm

8.3 Capacitive 43G Series

For increased sensitivity through acrylic or glass please contact us.

Item	43G
IC	GT911
I2C Slave Address	0xBA/0xBB or 0x28/0x29 (8bit)
Speed	400Kbps
Durability	64g steel ball at 100cm

9 Interface Description

9.1 40 pin RGB

Suggested mating FFC connector, 40 position, 0.5mm pitch, Top contact.

FFC Header	Part Number
Matrix Orbital	
Omron Electronics	XF2M-4015-1A

Pin	Name	Description
1	LEDK	Backlight Cathode
2	LEDA	Backlight Anode
3	CS	Chip Select CS=0 Chip Enable
4	VCC	Power
5-12	Red (0-7)	Red data signal
13-20	Green (0-7)	Green data signal
21-28	Blue (0-7)	Blue data signal
29	GND	Ground
30	CLK	Clock signal to sample each data
31	DISP	Display on/off signal. High Display on; Low Display off
32	HSYNC	Horizontal sync
33	VSNC	Vertical sync
34	DEN	Data enable
35	SCL	I2C clock
36	SDA	I2C data
37	XR	Resistive touch (-TPR) otherwise NC
38	YD	Resistive touch (-TPR) otherwise NC
39	XL	Resistive touch (-TPR) otherwise NC
40	YU	Resistive touch (-TPR) otherwise NC

9.2 Capacitive Touch

MOP-TFT480272-43A TPC

Suggested mating FFC connector, 6 position, 0.5mm pitch, Top contact.

FFC Header	Part Number
Matrix Orbital	
Molex	5034800600

Pin	Name	Description
1	SDA	I2C Data
2	SCL	I2C Clock
3	/INT	Interrupt
4	GND	Ground
5	VCC	Power
6	/RST	External Reset, Low is active

*Note: Pull up resistors of 10k ohms to VDD are recommended for RST and INT

**Note: Pull up resistors of 1k-10k ohms to VDD are required for SCL and SDA

MOP-TFT480272-43G TPC

Suggested mating FFC connector, 6 position, 0.5mm pitch, Top contact.

FFC Header	Part Number
Matrix Orbital	
Molex	5034800600

Pin	Name	Description
1	/RST	External Reset, Low is active
2	VCC	Power
3	GND	Ground
4	/INT	Interrupt
5	SCL	I2C Clock
6	SDA	I2C Data

*Note: Pull up resistors of 10K ohms to VDD are recommended for RST and INT

**Note: Pull up resistors of 1k-10k ohms to VDD are required for SCL and SDA

10 Interface Pixel Timing

Characteristics		Symbol	Min.	Typ.	Max.	Unit
DOTCLK Frequency		Fclk	8	9	12	MHz
Hsync	Period Time	Th	485	531	598	DCLK
	Display Period	Thdisp	-	480	-	DCLK
	Back Porch	Thbp	3	43	43	DCLK
	Front Porch	Thfp	2	8	75	DCLK
	HSYNC Width	Thw	2	4	43	DCLK
Vsync	Period Time	Tv	276	292	321	H
	Display Period	Tvdisp		272		H
	Back Porch	Tvbp	2	12	12	H
	Front Porch	Tvfp	2	8	37	H
	Pulse Width	Tvw	2	4	12	H

11 Power Sequence

11.1 Power Up Sequence

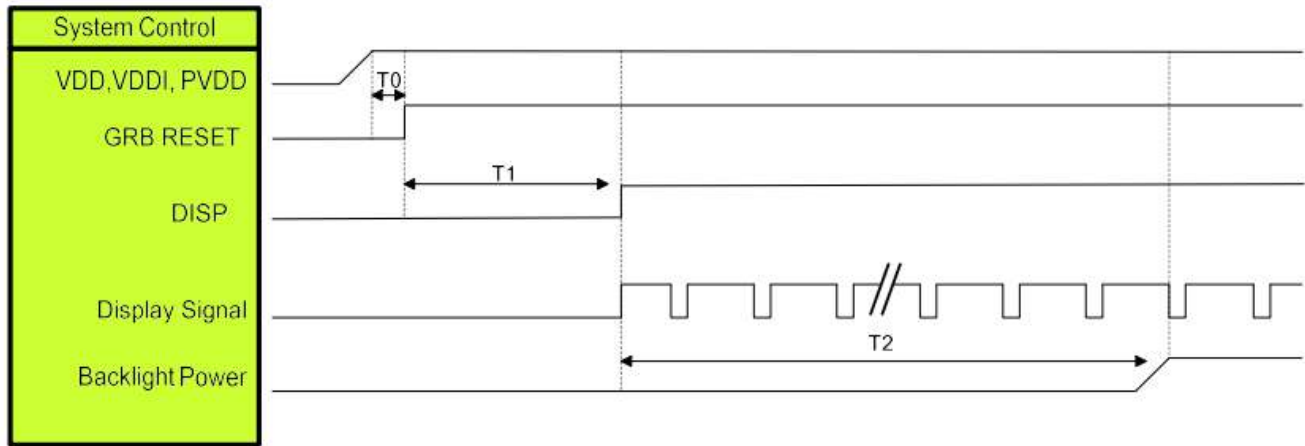

Symbol	Description	Min. Time	Unit
T0	System power stability to GRB RESET signal	0	ms
T1	GRB RESET= "High" to DISP="High"	10	ms
T2	Display Signal output to Backlight Power on	250	ms

Figure 1: Power Up Sequence

11.2 Power Down Sequence

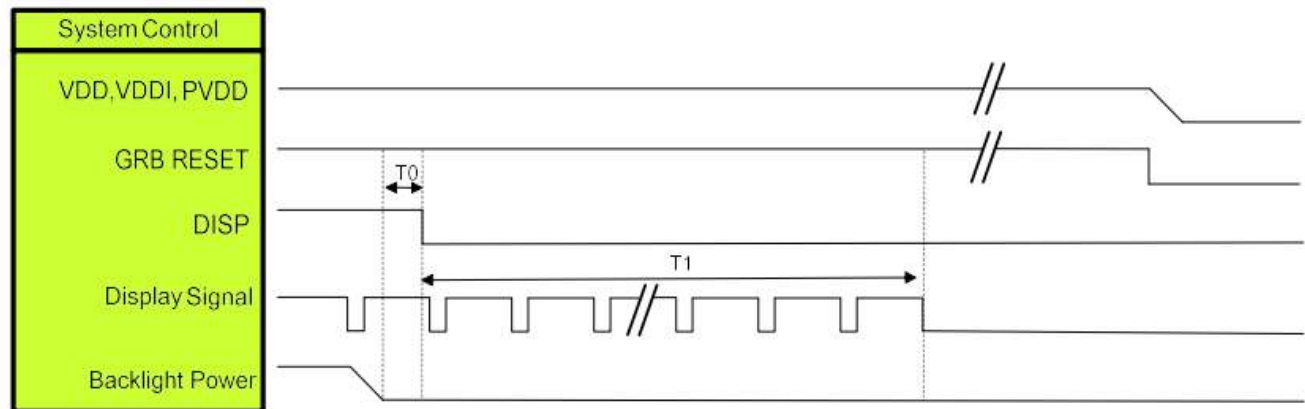

Symbol	Description	Min. Time	Unit
T0	Backlight Power off to DISP="Low"	5	ms
T1	DISP="Low" to IC internal voltage discharge complete	80	ms

12 Environmental

Item	Min	Max	Unit
Operation Temperature	-20	70	°C
Storage Temperature	-30	80	°C
Humidity		90%*	RH

*noncondensing

13 Suggested Products

EVE3x-43A/43G: 4.3" 480x272 SPI or USB TFT using the EVE3 graphics engine.

<https://www.matrixorbital.com/eve3-43a>

<https://www.matrixorbital.com/eve3-43g>

<https://www.matrixorbital.com/eve3x-43a>

<https://www.matrixorbital.com/eve3x-43g>

GTT43A: Intelligent UART 4.3" TFT USB, I2C, Serial, RS422 with software development tools.

<https://www.matrixorbital.com/gtt43a>

14 Inspection Criterion

Description

This specification is made to be used as the standard acceptance/rejection criteria.

Sample plan

Sampling plan:

1999 and ANSI/ASQC Z1.4-1993

Single sampling, normal inspection

Visual inspection: AQL 1.5%

Electrical functional: AQL 0.65%

Inspection condition

- Viewing distance for cosmetic inspection is about 30 ± 2 cm with bare eyes, and under a 1000~1500lux environment for visual inspection. All directions for inspecting the sample should be within 45° against perpendicular line. (Normal temperature $18 \sim 28^\circ\text{C}$ and normal humidity $60 \pm 15\% \text{RH}$).
- During testing, the LCD is driven using the voltage level (Within $\pm 0.5\text{V}$ of the typical value at 25°C .) that provides the most optical contrast

Definition of inspection zone in LCD

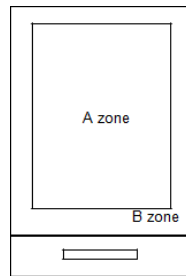

Zone A: Active Area

Zone B: Viewing Area

Function Defect

Items to be inspected	Inspection criterion	Classification of defects
All functional defects	1) No display 2) Display abnormally 3) Missing vertical, horizontal segment 4) Short circuit 5) Back-light no lighting, flickering and abnormal lighting.	MA

	6) obvious striation 7) Current beyond specification value	
Missing	Missing component	
Outline dimension	Overall outline dimension exceeds the drawing is not allowed.	

LCD pixel defect (bad dot) (defect type: MI)

Checking item	Judgment criterion	Total
Bright dot	0	0
Dark dot	$N \leq 2$	$N \leq 2$
Total dot	$N \leq 2$	$N \leq 2$
Mura	Not visible through 5% ND filters	

***Note:** Bright dot caused by scratch and foreign object accords to item 1.

Dot and line defect (defect type: MI)

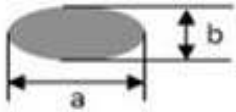
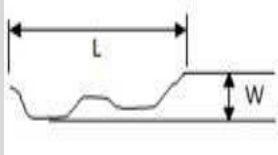
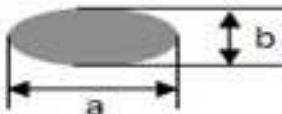
Checking item	Judgment criterion			Figure
	Diameter(mm)\LCD Size		S ≤5.0 Inch	
Dot defect	$D \leq 0.10$		Allowed	 $D = (a+b)/2$
	$0.10 < D \leq 0.15$		2	
	$0.15 < D \leq 0.25$		1	
	$0.25 < D$		0	
	Total		2	
	Distance between 2 defects should be more than 3mm apart.			
Line defect	Length(mm)	Width(mm)	Judgment criterion	
	---	$W \leq 0.03$	allowed	
	$L \leq 2.5$	$0.03 < W \leq 0.05$	3	
	$L \leq 2.5$	$0.05 < W \leq 0.10$	2	
	---	$0.1 < W$	0	
	Total		3	
Distance between 2 defects should more than 3mm apart. Scratches not viewable through the back of the display are acceptable				
Concave point and air bubble for polarizer	Size(mm)		Judgment criterion	 $D = (a+b)/2$
	$D \leq 0.20$		allowed	
	$0.20 < D \leq 0.30$		4	
	$0.30 < D \leq 0.50$		1	
	$D > 0.50$		None	

15 Handling Precautions

Mounting method

Do not make extra holes in the display or modify its shape. When mounting the display, ensure that the display does not flex, bend or twist. Extreme care should be used when handling the LCD modules.

LCD Handling and Cleaning Precaution

To clean the display surface, it is recommended to wipe lightly using a soft cloth with either Isopropyl alcohol or Ethyl alcohol. Do not wipe the display surface with dry or hard materials as it may damage the polarizer surface.

Do not use Water or Aromatics to clean the display.

Do not wipe ITO pad area with dry or hard materials that will damage the ITO patterns

Do not use Soldering flux, Chlorine (Cl), and Sulfur(S) on the pad or prevent it from being contaminated.

If the display is sent without applying a silicon coat on the pad, the ITO patterns could be damaged due to corrosion as time goes on.

If ITO corrosion occurs due to customer miss-handling, or if the customer applies materials such as Chlorine (Cl), Sulfur (S) to the display, the responsibility is placed the customer.

Static Charge Precaution

The LCD module uses CMOS LSI drivers, so we recommend that you:

- Connect any unused input terminal to VDD or VSS
- Do not input any signals before power is turned on
- Ground your body, work/assembly areas, and assembly equipment to protect against static electricity.

Packing

The module employs LCD elements and must be treated as such.

- Avoid intense shock and falls from a height.
- To prevent modules from degradation, do not operate or store them exposed direct to sunshine or high temperature/humidity

Precautions during Operation

- It is an indispensable condition to drive the LCD module within the specified voltage limits. Applying voltage higher than the limit will reduce the life span of the LCD.
- Using direct drive current should be avoided, as it will induce an electrochemical reaction causing undesirable deterioration.
- The LCD's response time will be delayed when operating at a temperature lower than the suggested operating range. When operating at a temperature higher than the suggested range, the LCD will be noticeably darker. The display will return to normal when it is brought back to the specified operation temperature.
- If the display area is pushed hard during operation, some font may be abnormally drawn but the LCD will return to normal after it is reset.
- Slight dew depositing on terminals can cause an electro-chemical reaction, damaging traces and resulting in an open circuit.

Usage under the maximum operating temperature, 50%Rh or less is required

Storage Recommendations

When storing the LCD for a prolonged period of time, the following recommendations will help prevent damage or deterioration

- Store the display in an ambient temperature range between 10°C to 30°C, and in a relative humidity of 45% to 75%.
- Do not leave the display exposed to sunlight or fluorescent light.
- Place the display in a polyethylene bag with the opening sealed.
- Ensure that nothing is making contact with the polarizer surface.
- It is recommended to store them in the same packaging that was provided upon purchase

Safety Precautions

In the case that the LCD glass has shattered, it is recommended to remove any glass pieces, wash off the liquid crystal using either acetone or ethanol, and proceed to burn any remaining display pieces.

If any liquid leaked out of a damaged glass cell, and comes in contact with your hands, please wash it off well with soap and water

16 Revision History

Revision	Date	Description	Author
1.0	July 1 2020	Initial Release	Henry