

DO NOT SCALE FROM THIS PRINT

XDMX-XX-X-XX.XX-XXX-XXX

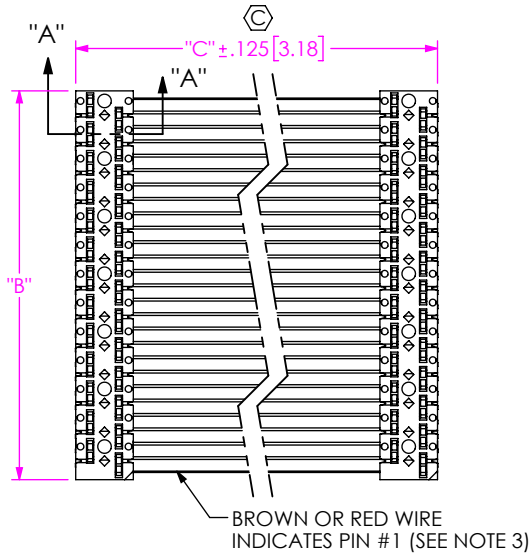

TAIL SPECIFICATION
(SEE SECT "A"- "A" & "B"- "B")
I: D = .125[3.18] (T-1S7-01-X)
**E: D = .200[5.08] (T-1S7-02-X)

ROW SPECIFICATION
-S: SINGLE
-D: DOUBLE

NO OF CONDUCTORS (SEE NOTE 3)
(-02 THRU -32 PER ROW)
USE CABLE CB-XX-28-7/36-100-C (XDMS)
USE CABLE CB-XX-28-7/36-050-C (XDMD)
"A" ±.015 [0.38] = "XX" X .100[2.54] + .019[0.48] (-01 THRU -31)
OR 3.210[81.53] REF (-32)
"B" ±.015 [0.38] = "XX" X .100[2.54] + .059[1.50] (-01 THRU -31)
OR 3.250[82.55] REF (-32)
* NOTE: STANDARD COLOR-CODED CABLE N/A FOR DOUBLE ROW 31 & 32 POSITION - SEE -G OPTION.

OPTION SPECIFICATION
SEE OPTIONS
(SEE SHT 2 & SHT 3)

OPTION SPECIFICATION
SEE OPTIONS
(SEE SHT 2 & SHT 3)

LENGTH OF CABLE
MEASURED IN INCHES
(SEE FIG 1, "C" DIM)

CONNECTOR SPECIFICATION
-S: (SINGLE) ONE XDM ASSEMBLY
-D: (DOUBLE) TWO XDM ASSEMBLIES
-ONE ON EACH END
-T: (TRANSFER-IDS) ONE XDMS & ONE IDS
-ONE ON EACH END
-T: (TRANSFER-IDMD) ONE XDMD & ONE IDD
-ONE ON EACH END

** = EXISTING CUSTOMERS ONLY

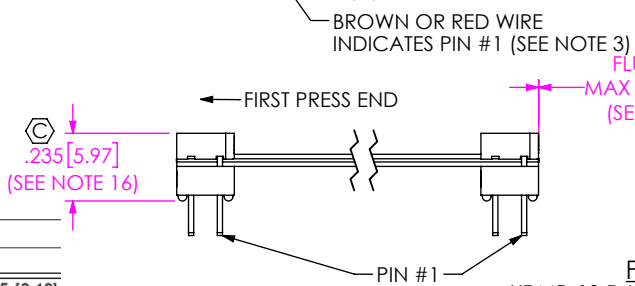

FIG 1
XDMD-13-D-XX.XX-X-X SHOWN

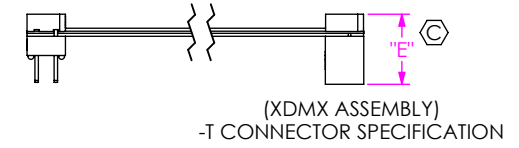
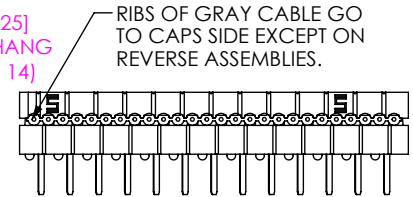
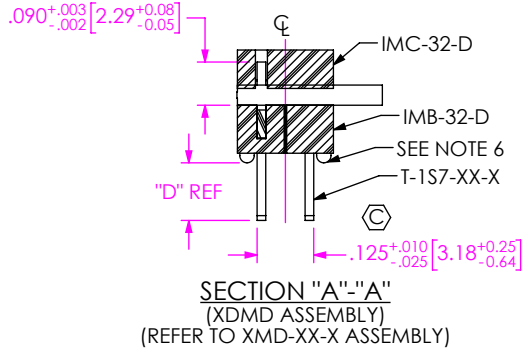
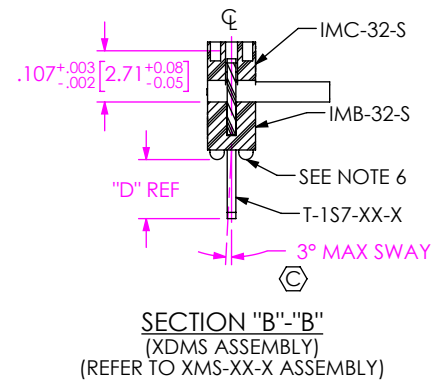

FIG 3
XDMD-13-D-XX.XX-X-X-T SHOWN
(DIFFERENT AS SHOWN, OTHERWISE SAME AS FIG 1)

TABLE 1		
No. OF POS	"E"	
2, 3, 4	.360 [9.144]	+ .005 [0.13] - .000 [0.00]
5 AND UP	.365 [9.271]	+ .010 [0.25] - .005 [0.13]



SECTION "A"- "A"
(XDMD ASSEMBLY)
(REFER TO XMD-XX-X ASSEMBLY)



SECTION "B"- "B"
(XDMS ASSEMBLY)
(REFER TO XMS-XX-X ASSEMBLY)

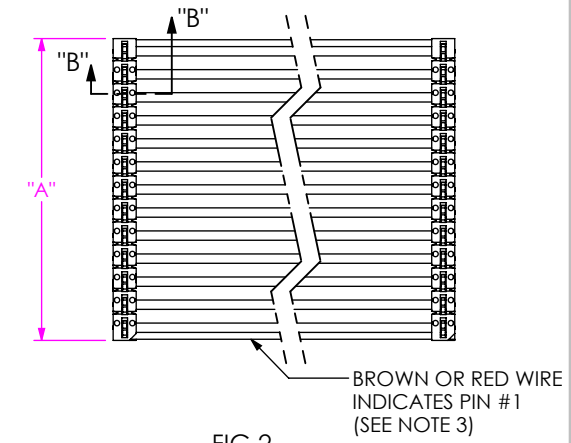

FIG 2
XDMS-13-D-XX.XX-X-X SHOWN
(DIFFERENT AS SHOWN, OTHERWISE SAME AS FIG 1)

NOTES:

- ⊕ REPRESENTS A CRITICAL DIMENSION.
- OPTION -SXX WHEN MATING DOUBLE ROW CONNECTOR WITH 2 SINGLE ROW CONNECTORS, THE OUTER MOST SINGLE WILL BE CONNECTED TO CONDUCTOR #1 AND THE INSIDE SINGLE TO CONDUCTOR #2.
- ON FIRST CABLE INSERTION PRESS, THE BROWN WIRE (COLORED CABLE) OR THE RED WIRE (GRAY CABLE) IS POSITIONED TO THE RIGHT WITH THE "FAT END" OF THE BASE AND CAP.
- WHEN CUTTING BASE AND CAPS TO POSITION, END WALLS ON CUT ENDS SHALL BE .010 [0.25] MIN.
- NOTE DELETED.
- STANDOFFS ON BASE SHALL STAND .010 [0.25] MIN. FROM SURFACE OF IMB-32-X.
- OPTION -PXX: POLARIZING OPTION CAN ONLY BE USED ON IDX END OF -T (TRANSFER) OPTION.
- WHEN DAISY CHAINING A TRANSFER END OPTION, ONLY THE FIRST CONNECTOR IS MALE; THE REMAINING CONNECTORS ARE FEMALE.
- A CHAMFER ON THE END OF THE CAP IS GUARANTEED ON FINAL ASSEMBLIES THAT ARE AT LEAST 18 POSITIONS FOR MALE AND FEMALE TERMINATION.
- ALL ASSEMBLIES TO BE 100% ELECTRICALLY TESTED FOR SHORTS AND OPENS.
- ALL ASSEMBLIES TO BE 100% HI-POT TESTED AT 1000V.
- CONTACT NOT TO BE VISIBLE THROUGH THE END WALL OF IMC-32-X CAP.
- REFERENCE XMD-XX-X (AND IDS-XX-X-PXX OR IDD-XX-X FOR -T OPTION) FOR CUT DIMENSIONS.
- WHEN CUTTING CABLE TO LENGTH, CONDUCTORS SHOULD NOT EXTEND PAST THE CABLE INSULATION, EXTENDING LESS THAN 25% OF CABLE THICKNESS ON CONSECUTIVE AND LESS THAN 50% OF CABLE THICKNESS ON NON-CONSECUTIVE STRANDS IS CONSIDERED A PROCESS INDICATOR.
- PACKAGE TERMINAL ENDS WITH CS-IDC002 CLAMSHHELLS; PACKAGE -STX OPTIONS USING SKIN PACKAGING.
- DEMINSION FROM TOP OF CAP TO STANDOFF.
- SAME AS -SXX EXCEPT OUTER STRIP CONNECTED TO CONDUCTOR #2 AND INSIDE STRIP CONNECTED TO CONDUCTOR #1.

UNLESS OTHERWISE SPECIFIED, DIMENSIONS ARE IN INCHES.
TOLERANCES ARE:
DECIMALS ANGLES
.XX: ±.01 [0.3] 2°
.XXX: ±.005 [0.13]
.XXXX: ±.0020 [0.051]

PROPRIETARY NOTE
THIS DOCUMENT CONTAINS CONFIDENTIAL AND PROPRIETARY INFORMATION AND ALL DESIGN, MANUFACTURING, REPRODUCTION, USE, PATENT RIGHTS AND SALES RIGHTS ARE EXPRESSLY RESERVED BY SAMTEC, INC. THIS DOCUMENT SHALL NOT BE DISCLOSED, IN WHOLE OR PART, TO ANY UNAUTHORIZED PERSON OR ENTITY NOR REPRODUCED, TRANSFERRED OR INCORPORATED IN ANY OTHER PROJECT IN ANY MANNER WITHOUT THE EXPRESS WRITTEN CONSENT OF SAMTEC, INC.



520 PARK EAST BLVD., NEW ALBANY, IN 47150
PHONE: 812-944-6733 FAX: 812-948-5047
e-Mail: info@SAMTEC.com code 55322

MATERIAL: DO NOT SCALE DRAWING SHEET SCALE: 2:1
INSULATOR: VALOX DR-48, COLOR: BLACK
CONTACT: BeCu
TERMINAL: PHOSPHOR BRONZE
CABLE: TINNED COPPER/PVC

DESCRIPTION:
ASSEMBLY INSULATION DISPLACEMENT TERMINAL CONNECTOR
DWG. NO.
XDMX-XX-X-XX.XX-XXX-XXX
BY: JORDAN 12/30/1987 SHEET 1 OF 3

OPTION	CONTACTS
-T	T-1S7-XX-T (XDMX) C-10-T (IDSX)
-C***	T-1S7-XX-T (XDMX) C-10-G (IDSX)
-A***	T-1S7-XX-G (XDMX) C-10-T (IDSX)

***CAN ONLY BE USED WITH CONNECTOR SPECIFICATION -T

PLATING
-T, -C*** OR -A***

SUBSTITUTE GRAY CABLE FOR STANDARD COLOR CODED CABLE.

XDMD: CB-XX-28-7/36-050-G
XDMS: CB-XX-28-7/36-100-G
(SEE FIG 1)

NOTE: USE GRAY CABLE FOR DOUBLE ROW, -31 & -32 POSITION.

-G
GRAY CABLE

- NOTE:
1. CONDUCTORS SHALL BE CONSISTENT IN APPEARANCE. SOLDER MUST MAINTAIN CABLE STRAINS WITHIN THE MAX DIA. TOLERANCE.
 2. USE 60/40 TIN/LEAD SOLDER ONLY.
 3. NOT AVAILABLE IN 28 POSITION AND UP IN DOUBLE ROW ONLY.

ST "X"	"L"
ST8	.125 [3.18]
ST4	.250 [6.35]
ST3	.375 [9.53]
ST2	.500 [12.70]

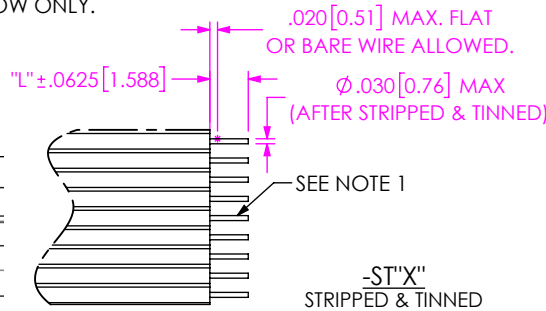

-ST"X"
STRIPPED & TINNED

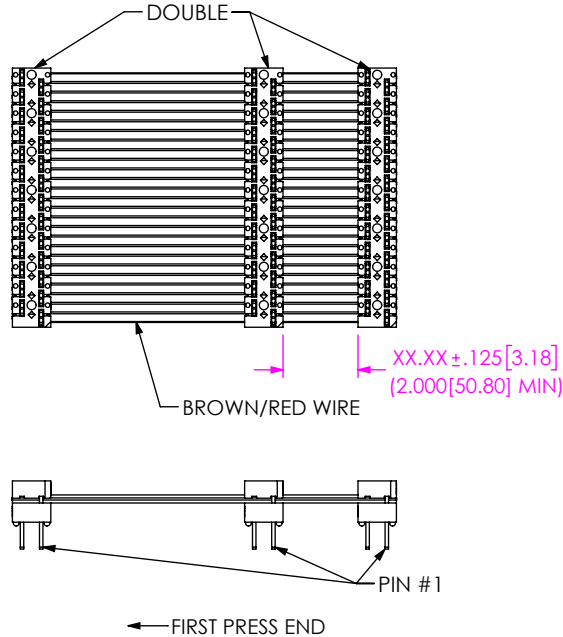
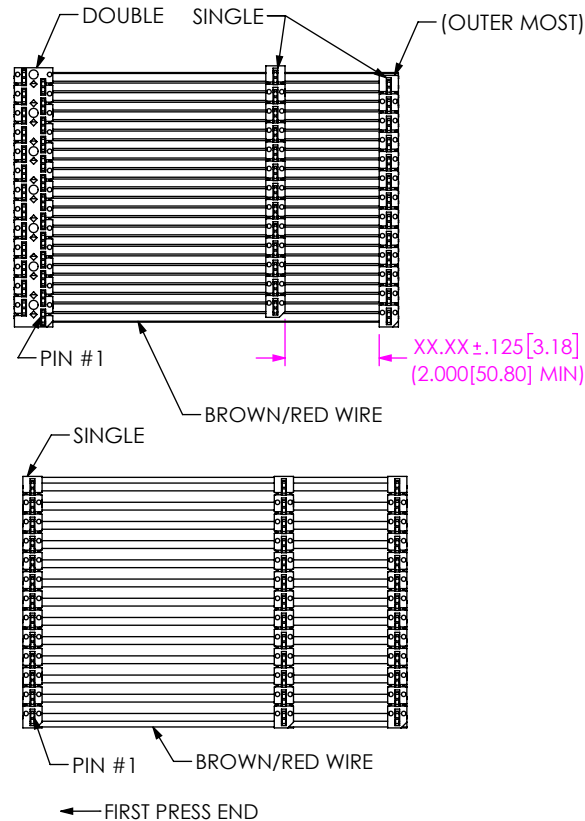
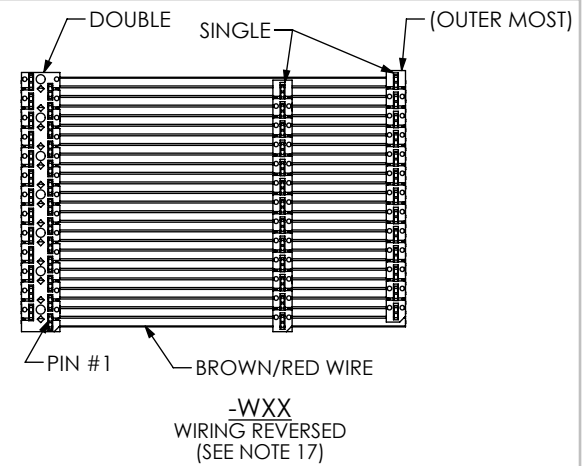

-DXX
DAISY CHAIN - DOUBLE

2 INCH MINIMUM LENGTH;
ONE INCH INCREMENTS ONLY

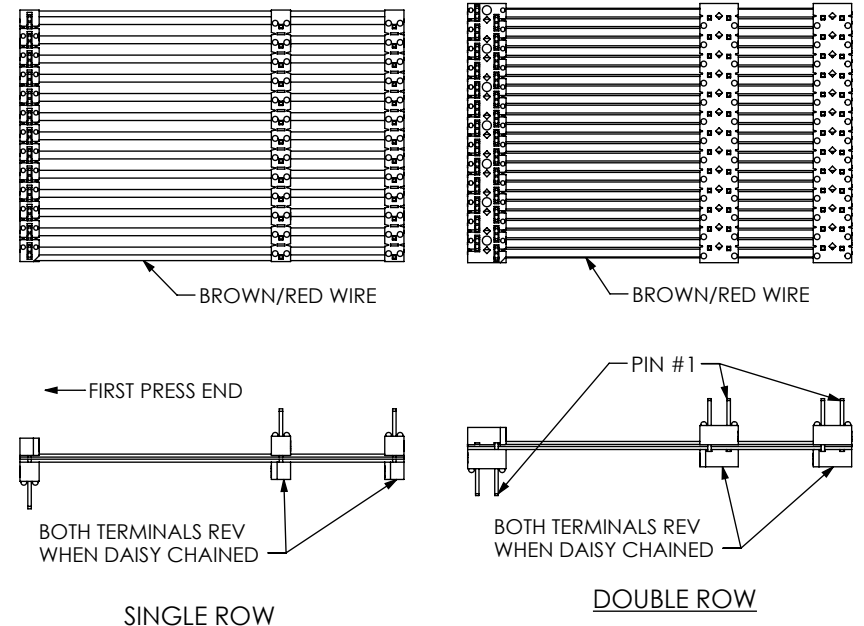

-R
REVERSED CONNECTOR
(NOT AVAILABLE WITH -M OR -O OPTIONS)

-SXX
DAISY CHAIN - SINGLE
(SEE NOTE 2 & 8)

2 INCH MINIMUM LENGTH;
ONE INCH INCREMENTS ONLY

PROPRIETARY NOTE
THIS DOCUMENT CONTAINS CONFIDENTIAL AND PROPRIETARY INFORMATION AND ALL DESIGN, MANUFACTURING, REPRODUCTION, USE, PATENT RIGHTS AND SALES RIGHTS ARE EXPRESSLY RESERVED BY SAMTEC, INC. THIS DOCUMENT SHALL NOT BE DISCLOSED, IN WHOLE OR PART, TO ANY UNAUTHORIZED PERSON OR ENTITY NOR REPRODUCED, TRANSFERRED OR INCORPORATED IN ANY OTHER PROJECT IN ANY MANNER WITHOUT THE EXPRESS WRITTEN CONSENT OF SAMTEC, INC.



520 PARK EAST BLVD, NEW ALBANY, IN 47150
PHONE: 812-944-6733 FAX: 812-948-5047
e-Mail: info@SAMTEC.com code 55322

DO NOT SCALE DRAWING

SHEET SCALE: 2:1

DESCRIPTION:
ASSEMBLY INSULATION DISPLACEMENT TERMINAL CONNECTOR

DWG. NO.
XDMX-XX-X-XX.XX-XXX-XXX

BY: JORDAN 12/30/1987 SHEET 2 OF 3

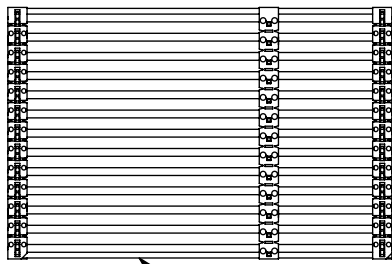

BROWN/RED WIRE

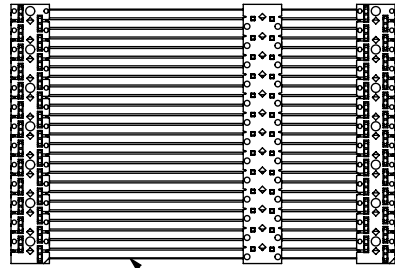

BROWN/RED WIRE

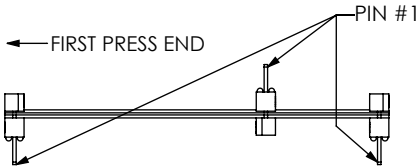

SINGLE ROW

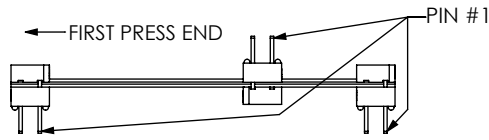

DOUBLE ROW

-M
MIDDLE REVERSED
(REQUIRES -SXX, -WXX OR -DXX OPTIONS)
(NOT AVAILABLE WITH -R OR -O OPTIONS)

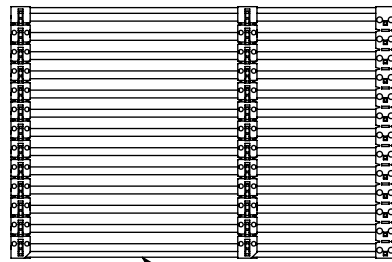

BROWN/RED WIRE

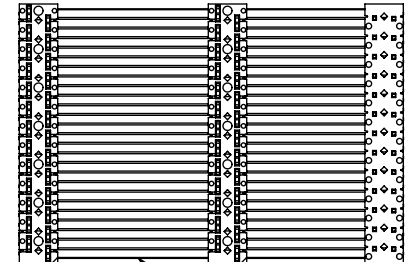

BROWN/RED WIRE

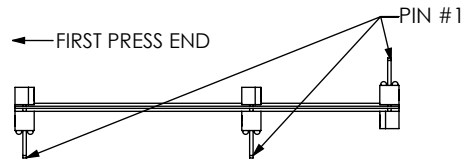

SINGLE ROW

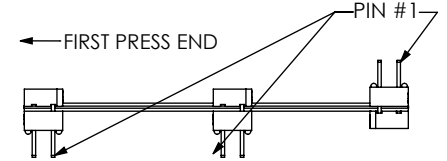

DOUBLE ROW

-O
OUTSIDE REVERSED
(REQUIRES -SXX, -WXX OR -DXX OPTIONS)
(NOT AVAILABLE WITH -R OR -M OPTIONS)

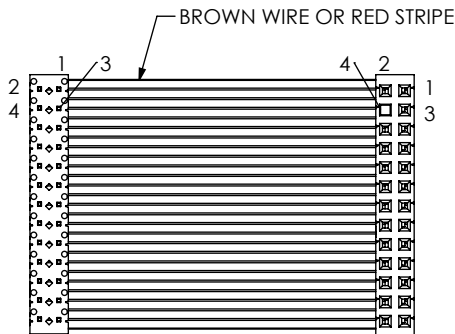

IDMD

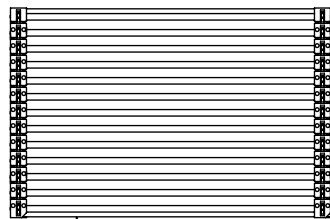

BROWN OR RED WIRE INDICATES PIN #1

SINGLE ROW

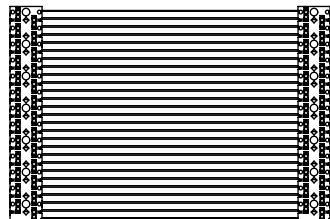

BROWN OR RED WIRE INDICATES PIN #1

DOUBLE ROW

STANDARD WIRING

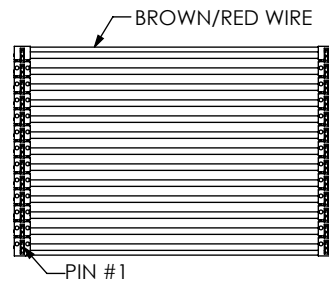

SINGLE ROW

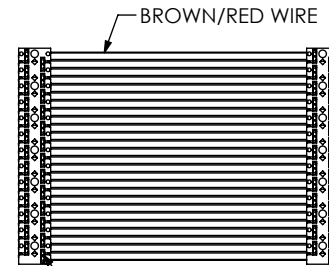

DOUBLE ROW

-RW
REVERSED WIRING

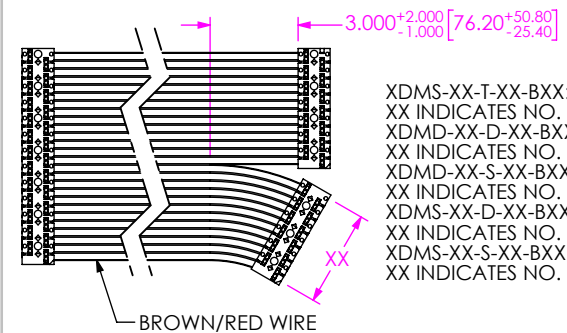

XDMS-XX-T-XX-BXX:
XX INDICATES NO. OF POSITIONS
XDMD-XX-D-XX-BXX:
XX INDICATES NO. OF CONDUCTORS
XDMD-XX-S-XX-BXX:
XX INDICATES NO. OF CONDUCTORS
XDMS-XX-D-XX-BXX:
XX INDICATES NO. OF POSITIONS
XDMS-XX-S-XX-BXX:
XX INDICATES NO. OF POSITIONS

NOTE: MUST HAVE EVEN NUMBER OF BREAKOUT POSITIONS ON DOUBLE ROW ASSEMBLIES

PROPRIETARY NOTE
THIS DOCUMENT CONTAINS CONFIDENTIAL AND PROPRIETARY INFORMATION AND ALL DESIGN, MANUFACTURING, REPRODUCTION, USE, PATENT RIGHTS AND SALES RIGHTS ARE EXPRESSLY RESERVED BY SAMTEC, INC. THIS DOCUMENT SHALL NOT BE DISCLOSED, IN WHOLE OR PART, TO ANY UNAUTHORIZED PERSON OR ENTITY NOR REPRODUCED, TRANSFERRED OR INCORPORATED IN ANY OTHER PROJECT IN ANY MANNER WITHOUT THE EXPRESS WRITTEN CONSENT OF SAMTEC, INC.



520 PARK EAST BLVD, NEW ALBANY, IN 47150
PHONE: 812-944-6733 FAX: 812-948-5047
e-Mail info@SAMTEC.com code 55322

DO NOT SCALE DRAWING

SHEET SCALE: 1:1

DESCRIPTION:
ASSEMBLY INSULATION DISPLACEMENT TERMINAL CONNECTOR

DWG. NO.
XDMX-XX-X-XX.XX-XXX-XXX

BY: JORDAN 12/30/1987 SHEET 3 OF 3

NOTE:
1. INSERT POLARIZING KEY PART NO. PK-06 INTO SPECIFIED POSITION -XX OF IDS END OF -T (TRANSFER) END ONLY.
2. POLARIZED POSITION WILL HAVE SAME ELECTRICAL POSITION FROM BROWN WIRE.