

High sensitivity, high-frequency accelerometers

736 and 736T

SPECIFICATIONS

Sensitivity, $\pm 5\%$, 25°C		100 mV/g
Acceleration range		50 g peak
Amplitude nonlinearity		1%
Frequency response:		
	$\pm 5\%$	5 - 15,000 Hz
	± 3 dB	2 - 25,000 Hz
Resonance frequency		60 kHz
Transverse sensitivity, max		7% of axial
Temperature response:		
	-50°C	-10%
	+120°C	+5%
Power requirement:		
Voltage source		18 - 30 VDC
Current regulating diode		2 - 10 mA
Electrical noise, equiv. g:		
Broadband	2.5 Hz to 25 kHz	150 μ g
Spectral	10 Hz	10 μ g/ \sqrt Hz
	100 Hz	2 μ g/ \sqrt Hz
	1,000 Hz	1 μ g/ \sqrt Hz
	10,000 Hz	0.8 μ g/ \sqrt Hz
Output impedance, max		150 Ω
Bias output voltage		10 VDC
Grounding		case grounded
Temperature range		-50° to +120°C
Vibration limit		500 g peak
Shock limit		5,000 g peak
Electromagnetic sensitivity, equiv. g		100 μ g/gauss
Base strain sensitivity, max		0.005 g/ μ strain
Sensing element design		PZT, compression
Weight		13 grams
Case material		316L stainless steel
Mounting		10-32 tapped hole
Output connector		10-32 coaxial
Mating connector		R1
Recommended cabling		J93

Accessories supplied: SF1 mounting stud (metric mounting available); calibration data (level 3)



Key features

- Compact size
- Wide dynamic range
- Manufactured in ISO 9001 facility

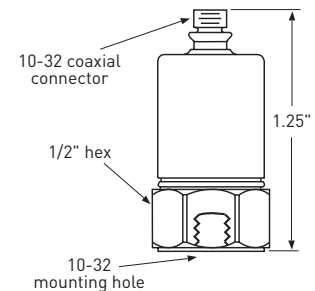

Model 736T

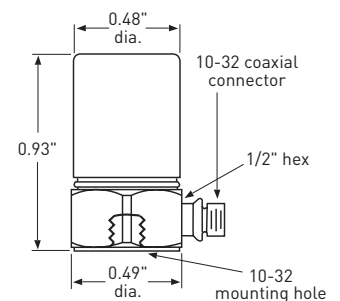

Model 736

Connections	
Function	Connector pin / cable conductor
power/signal	pin / center
common	shell / shield



Note: Due to continuous process improvement, specifications are subject to change without notice. This document is cleared for public release.