

# CS9202

## Micropower 3.3 V, 100 mA Linear Regulator with NOCAP™

The CS9202 is a precision 3.3 V, 100 mA voltage regulator with low quiescent current (450  $\mu$ A typ @ 100  $\mu$ A load). The 3.3 V output is accurate within  $\pm 2\%$  and supplies 100 mA of load current.

The regulator is protected against reverse battery, short circuit, over voltage, and over temperature conditions. The device can withstand 74 V peak transients making it suitable for use in automotive environments. ON's proprietary NOCAP solution is the first technology which allows the output to be stable without the use of an external capacitor. NOCAP is suitable for slow switching or steady loads.

### Features

- NOCAP
- Low Quiescent Current (450  $\mu$ A typ @ 100  $\mu$ A load)
- 3.3 V,  $\pm 2\%$  Output
- 100 mA Output Current Capability
- Fault Protection
  - 74 V Peak Transient Voltage
  - $-15$  V Reverse Voltage
  - Short Circuit
  - Thermal Shutdown
  - Overvoltage Shutdown
- Internally Fused Leads
- Pb-Free Packages are Available

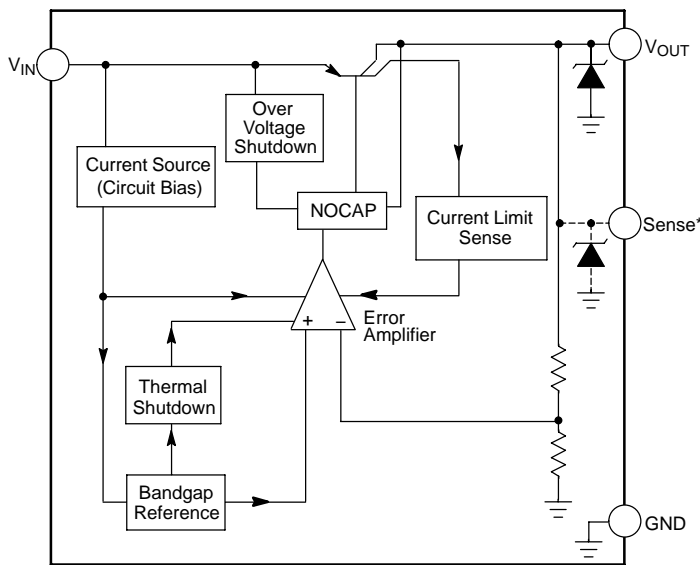

\*Contact factory for optional Sense lead.

Figure 1. Block Diagram



ON Semiconductor®

<http://onsemi.com>



SOIC-8  
DF SUFFIX  
CASE 751

### PIN CONNECTIONS AND MARKING DIAGRAM

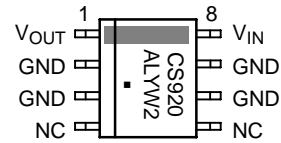

CS9202 = Device Code  
A = Assembly Location  
L = Wafer Lot  
Y = Year  
W = Work Week  
▪ = Pb-Free Package

### ORDERING INFORMATION

Device	Package	Shipping†
CS9202YDF8	SOIC-8	98 Units/Rail
CS9202YDF8G	SOIC-8 (Pb-Free)	98 Units/Rail
CS9202YDFR8	SOIC-8	2500 Tape & Reel
CS9202YDFR8G	SOIC-8 (Pb-Free)	2500 Tape & Reel

†For information on tape and reel specifications, including part orientation and tape sizes, please refer to our Tape and Reel Packaging Specification Brochure, BRD8011/D.

# CS9202

## MAXIMUM RATINGS

Parameter	Value	Unit
Power Dissipation	Internally Limited	–
Input Voltage ( $V_{IN}$ ): DC Peak Transient Voltage (60 V Load Dump @ $V_{IN} = 14$ V)	–15 to 36 74	V V
Output Current	Internally Limited	–
ESD Susceptibility (Human Body Model)	4.0	kV
Package Thermal Resistance: Junction-to-Case, $R_{\theta JC}$ Junction-to-Ambient, $R_{\theta JA}$	25 110	°C/W °C/W
Junction Temperature	–40 to +150	°C
Storage Temperature	–55 to +150	°C
Lead Temperature Soldering: Reflow (SMD styles only) (Note 1)	230 Peak	°C

Stresses exceeding Maximum Ratings may damage the device. Maximum Ratings are stress ratings only. Functional operation above the Recommended Operating Conditions is not implied. Extended exposure to stresses above the Recommended Operating Conditions may affect device reliability.

- 60 second maximum above 183°C.

## ELECTRICAL CHARACTERISTICS ( $4.5$ V $\leq V_{IN} \leq 26$ V, $I_{OUT} = 1.0$ mA, $-40^{\circ}\text{C} \leq T_J \leq 125^{\circ}\text{C}$ ; unless otherwise stated.)

Parameter	Test Conditions	Min	Typ	Max	Unit
-----------	-----------------	-----	-----	-----	------

### OUTPUT STAGE

Output Voltage, $V_{OUT}$	$9.0$ V $< V_{IN} < 16$ V, $100$ $\mu\text{A} \leq I_{OUT} \leq 100$ mA $4.5$ V $< V_{IN} < 26$ V, $100$ $\mu\text{A} \leq I_{OUT} \leq 100$ mA	3.234 3.201	3.300 3.300	3.366 3.399	V V
Load Regulation	$V_{IN} = 14$ V, $100$ $\mu\text{A} \leq I_{OUT} \leq 100$ mA	–	5	50	mV
Line Regulation	$4.5$ V $< V_{IN} < 26$ V, $I_{OUT} = 1.0$ mA	–	5	50	mV
Quiescent Current, ( $I_Q$ )	$I_{OUT} = 100$ $\mu\text{A}$ , $V_{IN} = 12$ V $I_{OUT} \leq 50$ mA $I_{OUT} \leq 100$ mA	–	450 4 12	750 6 20	$\mu\text{A}$ mA mA
Ripple Rejection	$7.0$ V $\leq V_{IN} \leq 17$ V, $I_{OUT} = 100$ mA, $f = 120$ Hz	60	75	–	dB
Current Limit	–	105	200	–	mA
Short Circuit Output Current	$V_{OUT} = 0$ V	25	125	–	mA
Thermal Shutdown (Note 2)	–	150	180	–	°C
Overvoltage Shutdown	$V_{OUT} \leq 1.0$ V	28	32	36	V

- This parameter is guaranteed by design, but not parametrically tested in production.

## PACKAGE LEAD DESCRIPTION

Package Lead Number SOIC–8	Lead Symbol	Function
1	$V_{OUT}$	3.3 V, $\pm 2\%$ , 100 mA output.
2, 3, 6, 7	GND	Ground.
4, 5	NC	No connection.
8	$V_{IN}$	Input voltage.

TYPICAL PERFORMANCE CHARACTERISTICS

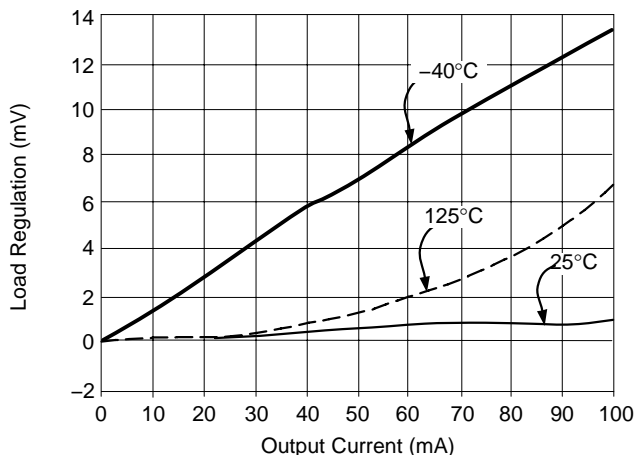

Figure 2. Load Regulation vs. Output Current  $V_{IN} = 14\text{ V}$

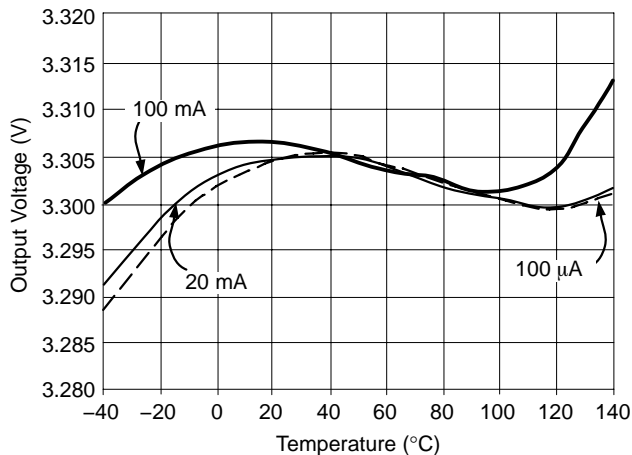

Figure 3. Output Voltage vs. Temperature  $V_{IN} = 14\text{ V}$

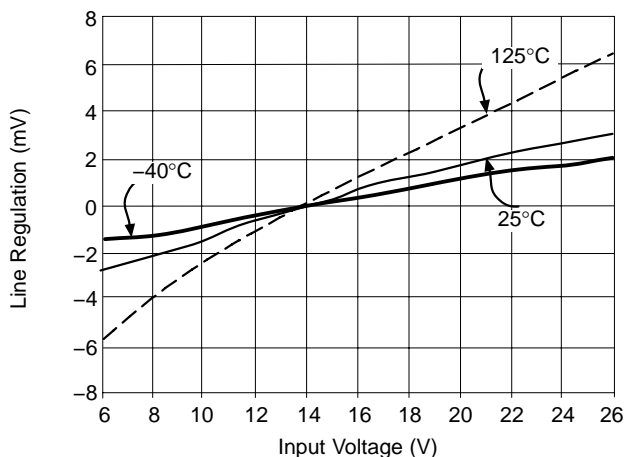

Figure 4. Line Regulation vs. Input Voltage  $I_{OUT} = 100\ \mu\text{A}$

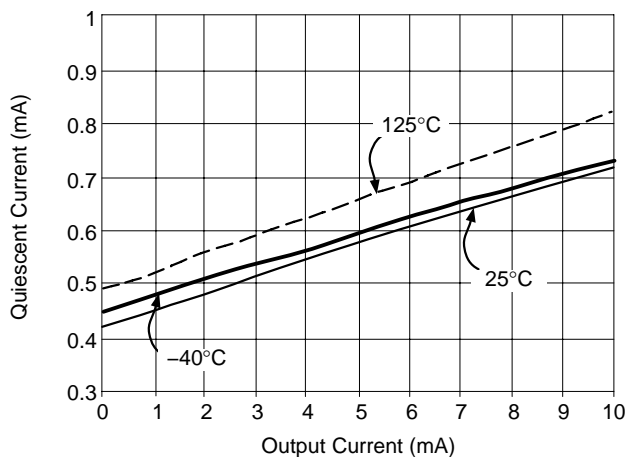

Figure 5. Quiescent Current vs. Output Current (Lightly Loaded)  $V_{IN} = 14\text{ V}$

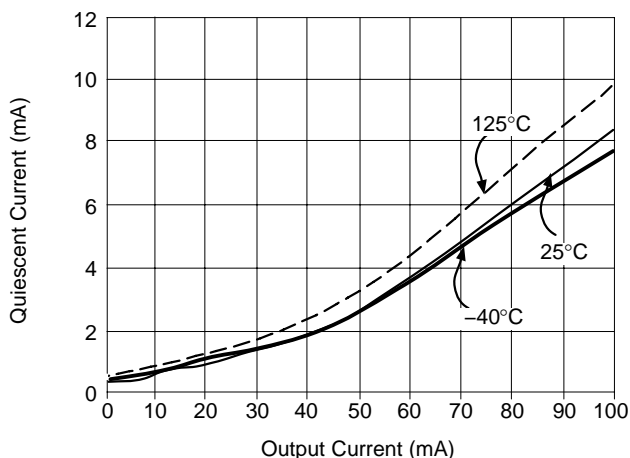

Figure 6. Quiescent Current vs. Output Current  $V_{IN} = 14\text{ V}$

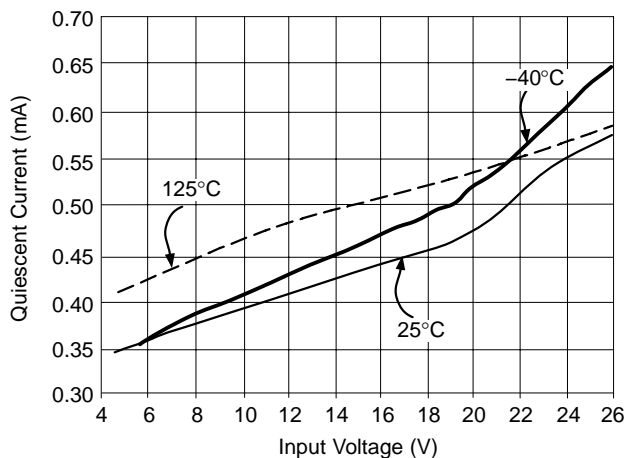

Figure 7. Quiescent Current vs. Input Voltage  $I_{OUT} = 100\ \mu\text{A}$

CIRCUIT DESCRIPTION

VOLTAGE REFERENCE AND OUTPUT CIRCUITRY

Output Stage Protection

The output stage is protected against overvoltage, short circuit and thermal runaway conditions (Figure 8).

If the input voltage rises above 32 V (typ), the output shuts down. This response protects the internal circuitry and enables the IC to survive unexpected voltage transients.

Should the junction temperature of the power device exceed 180°C (typ) the power transistor is turned off. Thermal shutdown is an effective means to prevent die overheating since the power transistor is the principle heat source in the IC.

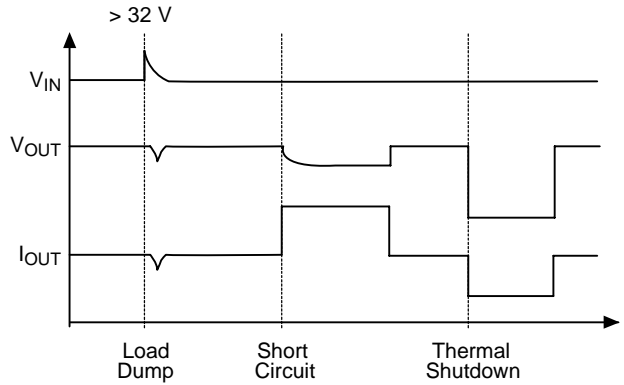
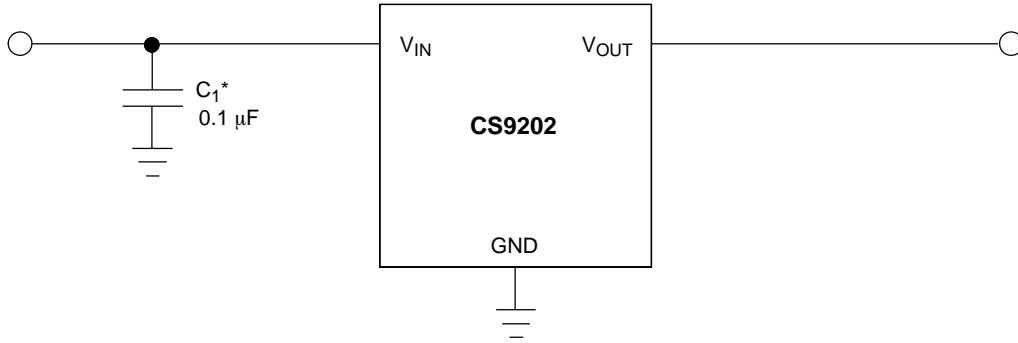

Figure 8. Typical Circuit Waveforms for Output Stage Protection



\* C1 is required if regulator is distant from power source filter.

Figure 9. Application and Test Diagram

APPLICATION NOTES

STABILITY CONSIDERATIONS / NOCAP

Normally a linear regulator (with a slow lateral PNP in the control loop) necessitates a large external compensation capacitor at the output of the IC. The external capacitor is also used to curtail offshoot, determine startup delay time and load transient response.

Traditional regulators typically have low unity gain bandwidth, display overshoot and poor ripple rejection. Compensation is also an issue and depends on the external capacitor value, ESR (Equivalent Series Resistance) and board layout parasitics that all can create oscillations if not properly accounted for.

NOCAP is an ON Semiconductor exclusive output stage which internally compensates the regulator over temperature, load and line variations without the need for an expensive external capacitor.

NOCAP is ideally suited for slow switching or steady loads. If the load is characterized by transient current events, an output storage capacitor may be needed. If this is the case, the capacitor should be no larger than 100 nF. With loads that require greater transient suppression, a regulator with a traditional output stage (such as the CS8221) may be better suited for proper operation.

**CALCULATING POWER DISSIPATION IN A SINGLE OUTPUT LINEAR REGULATOR**

The maximum power dissipation for a single output regulator (Figure 10) is:

$$P_{D(max)} = \{V_{IN(max)} - V_{OUT(min)}\} I_{OUT(max)} + V_{IN(max)} I_Q \quad (1)$$

where:

- $V_{IN(max)}$  is the maximum input voltage,
- $V_{OUT(min)}$  is the minimum output voltage,
- $I_{OUT(max)}$  is the maximum output current for the application, and
- $I_Q$  is the quiescent current the regulator consumes at  $I_{OUT(max)}$ .

Once the value of  $P_{D(max)}$  is known, the maximum permissible value of  $R_{\theta JA}$  can be calculated:

$$R_{\theta JA} = \frac{150^{\circ}\text{C} - T_A}{P_D} \quad (2)$$

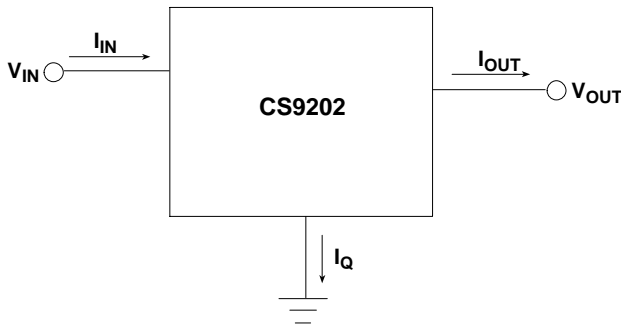

**Figure 10. Single output regulator with key performance parameters labeled.**

The value of  $R_{\theta JA}$  can then be compared with those in the package section of the data sheet. Those packages with  $R_{\theta JA}$ 's less than the calculated value in equation 2 will keep the die temperature below 150°C.

In some cases, none of the packages will be sufficient to dissipate the heat generated by the IC, and an external heatsink will be required.

**HEAT SINKS**

A heat sink effectively increases the surface area of the package to improve the flow of heat away from the IC and into the surrounding air.

Each material in the heat flow path between the IC and the outside environment will have a thermal resistance. Like series electrical resistances, these resistances are summed to determine the value of  $R_{\theta JA}$ :

$$R_{\theta JA} = R_{\theta JC} + R_{\theta CS} + R_{\theta SA} \quad (3)$$

where:

- $R_{\theta JC}$  = the junction-to-case thermal resistance,
- $R_{\theta CS}$  = the case-to-heatsink thermal resistance, and
- $R_{\theta SA}$  = the heatsink-to-ambient thermal resistance.

$R_{\theta JC}$  appears in the package section of the data sheet. Like  $R_{\theta JA}$ , it too is a function of package type.  $R_{\theta CS}$  and  $R_{\theta SA}$  are functions of the package type, heatsink and the interface between them. These values appear in heat sink data sheets of heat sink manufacturers.

# CS9202

## PACKAGE DIMENSIONS

SOIC-8 NB  
CASE 751-07  
ISSUE AH

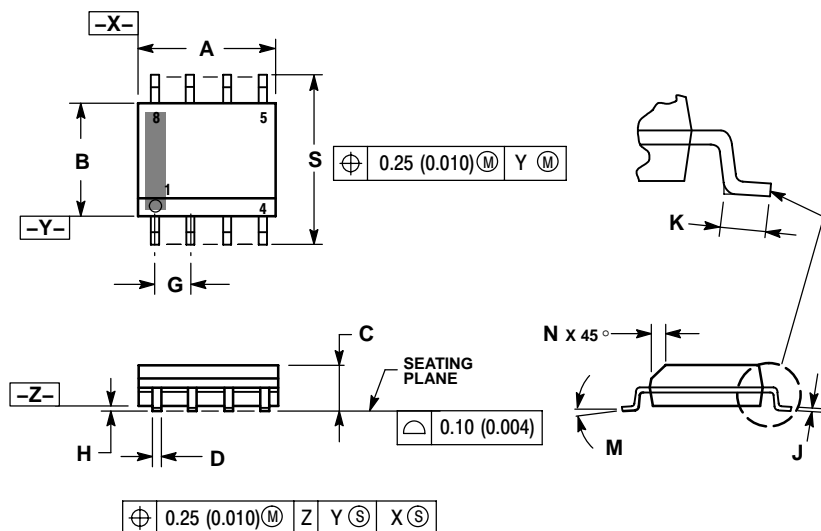

### NOTES:

1. DIMENSIONING AND TOLERANCING PER ANSI Y14.5M, 1982.
2. CONTROLLING DIMENSION: MILLIMETER.
3. DIMENSION A AND B DO NOT INCLUDE MOLD PROTRUSION.
4. MAXIMUM MOLD PROTRUSION 0.15 (0.006) PER SIDE.
5. DIMENSION D DOES NOT INCLUDE DAMBAR PROTRUSION. ALLOWABLE DAMBAR PROTRUSION SHALL BE 0.127 (0.005) TOTAL IN EXCESS OF THE D DIMENSION AT MAXIMUM MATERIAL CONDITION.
6. 751-01 THRU 751-06 ARE OBSOLETE. NEW STANDARD IS 751-07.

DIM	MILLIMETERS		INCHES	
	MIN	MAX	MIN	MAX
A	4.80	5.00	0.189	0.197
B	3.80	4.00	0.150	0.157
C	1.35	1.75	0.053	0.069
D	0.33	0.51	0.013	0.020
G	1.27 BSC		0.050 BSC	
H	0.10	0.25	0.004	0.010
J	0.19	0.25	0.007	0.010
K	0.40	1.27	0.016	0.050
M	$0^\circ$	$8^\circ$	$0^\circ$	$8^\circ$
N	0.25	0.50	0.010	0.020
S	5.80	6.20	0.228	0.244

### SOLDERING FOOTPRINT\*

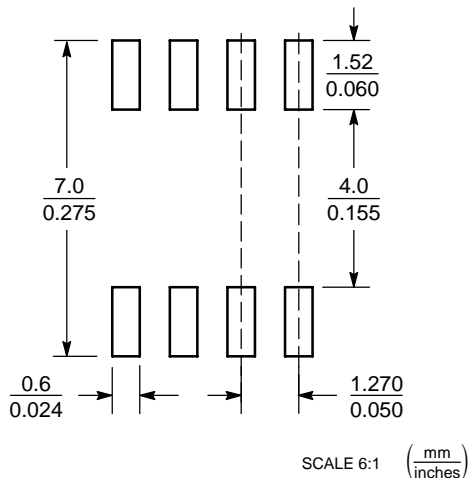

\*For additional information on our Pb-Free strategy and soldering details, please download the ON Semiconductor Soldering and Mounting Techniques Reference Manual, SOLDERRM/D.

NOCAP is a trademark of Semiconductor Components Industries, LLC.

ON Semiconductor and are registered trademarks of Semiconductor Components Industries, LLC (SCILLC). SCILLC reserves the right to make changes without further notice to any products herein. SCILLC makes no warranty, representation or guarantee regarding the suitability of its products for any particular purpose, nor does SCILLC assume any liability arising out of the application or use of any product or circuit, and specifically disclaims any and all liability, including without limitation special, consequential or incidental damages. "Typical" parameters which may be provided in SCILLC data sheets and/or specifications can and do vary in different applications and actual performance may vary over time. All operating parameters, including "Typicals" must be validated for each customer application by customer's technical experts. SCILLC does not convey any license under its patent rights nor the rights of others. SCILLC products are not designed, intended, or authorized for use as components in systems intended for surgical implant into the body, or other applications intended to support or sustain life, or for any other application in which the failure of the SCILLC product could create a situation where personal injury or death may occur. Should Buyer purchase or use SCILLC products for any such unintended or unauthorized application, Buyer shall indemnify and hold SCILLC and its officers, employees, subsidiaries, affiliates, and distributors harmless against all claims, costs, damages, and expenses, and reasonable attorney fees arising out of, directly or indirectly, any claim of personal injury or death associated with such unintended or unauthorized use, even if such claim alleges that SCILLC was negligent regarding the design or manufacture of the part. SCILLC is an Equal Opportunity/Affirmative Action Employer. This literature is subject to all applicable copyright laws and is not for resale in any manner.

### PUBLICATION ORDERING INFORMATION

**LITERATURE FULFILLMENT:**  
Literature Distribution Center for ON Semiconductor  
P.O. Box 5163, Denver, Colorado 80217 USA  
**Phone:** 303-675-2175 or 800-344-3860 Toll Free USA/Canada  
**Fax:** 303-675-2176 or 800-344-3867 Toll Free USA/Canada  
**Email:** orderlit@onsemi.com

**N. American Technical Support:** 800-282-9855 Toll Free  
USA/Canada  
**Europe, Middle East and Africa Technical Support:**  
Phone: 421 33 790 2910  
**Japan Customer Focus Center**  
Phone: 81-3-5773-3850

**ON Semiconductor Website:** [www.onsemi.com](http://www.onsemi.com)  
**Order Literature:** <http://www.onsemi.com/orderlit>

For additional information, please contact your local Sales Representative