

THIS DRAWING IS UNPUBLISHED. RELEASED FOR PUBLICATION ,19 .
 © COPYRIGHT 19 BY AMP INCORPORATED. ALL RIGHTS RESERVED.

LOC	DIST	REVISIONS			
P	LTR	DESCRIPTION	DATE	DWN	APVD
G	14	F	REV / 0720-0501-95	14FEB95	LO ME

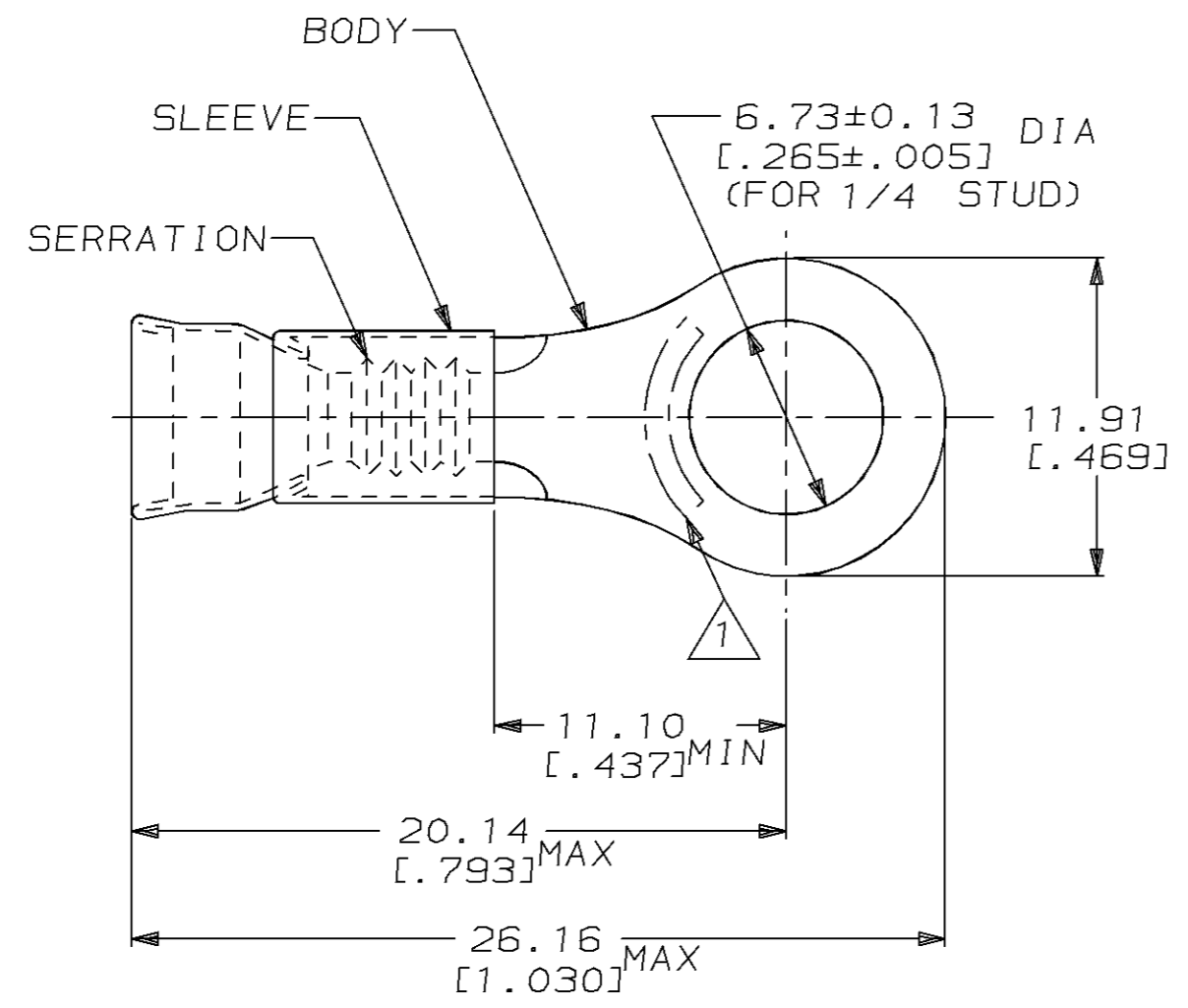

△ STAMP AMP 16-14* APPROX AS SHOWN

- 2. WIRE INSUL DIA, 3.05-4.32 [$.120-.170$]
- 3. TONGUE MATL THK, 0.79±0.05 [$.031 \pm .002$]

1000	LOOSE PIECE	322376
QTY	PACKAGE TYPE	PART NO

AMP INCORPORATED CUSTOMER SERVICE SYSTEM		MAX RECOMMENDED OPERATING TEMPERATURE: 343°C [650°F]	THIS DRAWING IS A CONTROLLED DOCUMENT FOR AMP INCORPORATED. IT IS SUBJECT TO CHANGE AND THE CONTROLLING ENGINEERING ORGANIZATION SHOULD BE CONTACTED FOR THE LATEST REVISION.		DWN L OLMEDA 100CT94	AMP Incorporated Harrisburg, PA 17105-3608
FOR ADDITIONAL PRODUCT INFORMATION OR COPIES OF DRAWINGS AND TECHNICAL DOCUMENTS	PRODUCT INFORMATION CENTER 1-800-522-6752		DIMENSIONS: mm [in]	TOLERANCES UNLESS OTHERWISE SPECIFIED:	CHK M ELLIS 100CT94	
FOR APPLICATION TOOLING INFORMATION	TOOLING ASSISTANCE CENTER 1-800-722-1111	VOLTAGE RATING: -		0 PLC ±-	1 PLC ±-	NAME TERMINAL, RING TONGUE, STRATOTHERM, DIAMOND GRIP, WIRE SIZE, 16-14 AWG
FOR ORDER ENTRY	1-800-526-5142	CIRCULAR MIL AREA: 1.04mm ² -2.62mm ² [2050-5180]		2 PLC ±0.20 [.008]	3 PLC ±-	4 PLC ±-
		STRANDED WIRE	MATERIAL BODY, CU PER ASTM B152 SLEEVE, NI SIL PER ASTM B122	FINISH BODY, NP, QQ-N-290	WEIGHT -	SIZE A3
			CUSTOMER DRAWING		CAGE CODE 00779	DRAWING NO C-322376
					SCALE 4:1	SHEET 1 OF 1
					REV F	