

REVISIONS					
P	LTR	DESCRIPTION	DATE	DRN	APPO
G1		REVISED PER ECN-22-179617	28SEP2022	PT	SZ

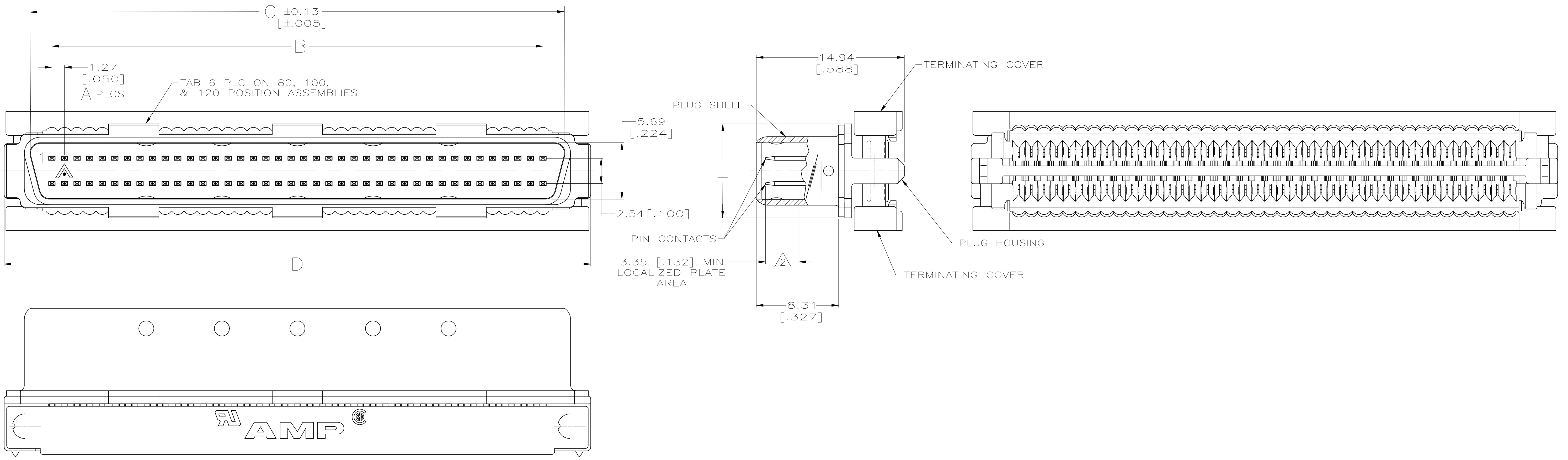

1 MATERIAL:  
 PIN CONTACTS - PHOSPHOR BRONZE.  
 PLUG SHELL - STEEL.  
 PLUG HOUSING & TERMINATING COVERS - UL V-O RATED THERMOPLASTIC; COLOR: BLACK.

2 FINISH:  
 PIN CONTACTS - EITHER 0.76µm [.000030] MIN GOLD PLATE OR GOLD FLASH OVER PALLADIUM NICKEL PLATE, 0.76µm [.000030] MIN TOTAL IN LOCALIZED PLATE AREA, 3.00µm [.000118] MIN TIN IN TERMINATION AREA, ALL OVER 1.27µm [.000050] MIN NICKEL.  
 PLUG SHELL - 0.25µm [.000010] MIN TIN-NICKEL OVER 3.81µm [.000150] MIN NICKEL OVER 2.54µm [.000100] MIN COPPER.

3 RECOMMENDED WIRE: 28 AWG OR 30 AWG, SOLID OR 7 STRAND, PVC INSULATION WITH A 0.74-0.91 [.029-.036] INSULATION DIAMETER.

	2	7.44 [.293]	24.87 [.979]	19.61 [.772]	15.24 [.600]	12	26	1-5749111-0
OBSOLETE	2	9.47 [.373]	84.56 [3.329]	79.30 [3.122]	74.93 [2.950]	59	120	5749111-9
	2	9.47 [.373]	71.86 [2.829]	66.60 [2.622]	62.23 [2.450]	49	100	5749111-8
	2	9.47 [.373]	59.16 [2.329]	53.90 [2.122]	49.53 [1.950]	39	80	5749111-7
	2	7.44 [.293]	51.54 [2.029]	46.28 [1.822]	41.91 [1.650]	33	68	5749111-6
	2	7.44 [.293]	40.11 [1.579]	34.85 [1.372]	30.48 [1.200]	24	50	5749111-4
	2	7.44 [.293]	33.76 [1.329]	28.50 [1.122]	24.13 [1.950]	19	40	5749111-3
	2	7.44 [.293]	21.06 [.829]	15.80 [.622]	11.43 [.450]	9	20	5749111-1
	FINISH	E	D	C	B	A	NO OF POSN	PART NO

THIS DRAWING IS A CONTROLLED DOCUMENT.

DIMENSIONS: mm [INCHES]	TOLERANCES UNLESS OTHERWISE SPECIFIED:	APPROVED: M. WALSLEY	DATE: 02-23-05
0. PLC ± -	1. PLC ± -	NAME: PLUG ASSEMBLY, AMPLIMITE .050 Series	RESTRICTED TO: -
2. PLC ± 0.38 [.015]	3. PLC ± -	PRODUCT SPEC: 108-1228	SIZE: A1
4. PLC ± -	ANGLES ± -	APPLICATION SPEC: 114-40029	SCALE: 5:1
MATERIAL: 1	FINISH: SEE TABLE	WEIGHT: 0.000000	SHEET: 1 of 1
		CUSTOMER DRAWING	REV: G1

STE TE Connectivity