

Customer Information Sheet

DRAWING No.: H2101-01 TO H2103-01

IF IN DOUBT - ASK

©

NOT TO SCALE

THIRD ANGLE PROJECTION

ALL DIMENSIONS IN mm

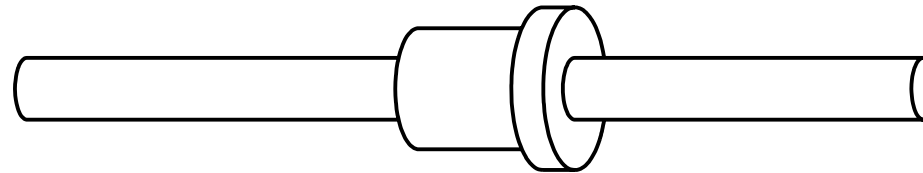
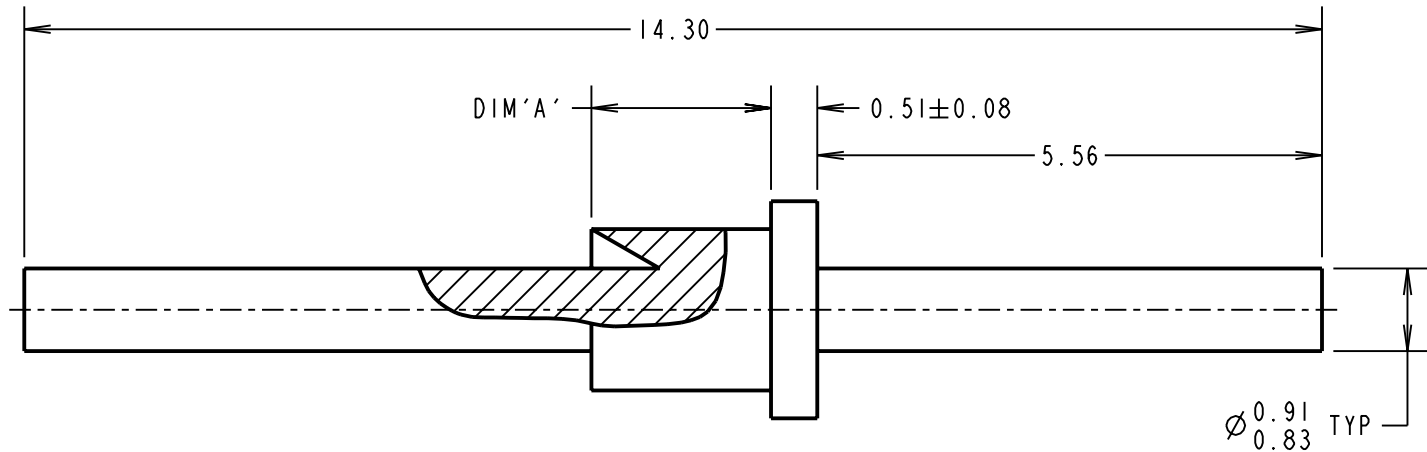
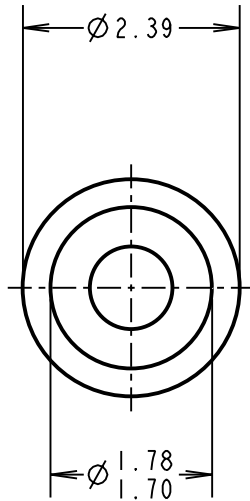

NOTES:
1. UNLESS OTHERWISE STATED, TOLERANCES = ± 0.13

PART No.	DIM 'A'	HOLE SIZE	BOARD THICKNESS	PUNCH AND DIE TOOL
H2101-01	1.98 / 2.11	Ø 1.79/1.87mm	1.60mm	Z2101-00
H2102-01	2.79 / 2.92	Ø 1.79/1.87mm	2.40mm	Z2102-00
H2103-01	3.56 / 3.69	Ø 1.79/1.87mm	3.20mm	Z2103-00

CP	17	25.08.09	10446
NAME	ISS.	DATE	C/NOTE
APPROVED: C.PENROSE			
CHECKED: R.ADDE			
DRAWN: A. LIOTTA			
CUSTOMER REF.:			
ASSEMBLY DRG:			

HARWIN

THIS DRAWING AND ANY INFORMATION OR DESCRIPTIVE MATTER SET OUT HEREON ARE CONFIDENTIAL AND COPYRIGHT PROPERTY OF THE HARWIN GROUP AND MUST NOT BE DISCLOSED, LOANED, COPIED OR USED FOR MANUFACTURING, TENDERING OR FOR ANY OTHER PURPOSE WITHOUT THEIR WRITTEN PERMISSION.

TOLERANCES
 X = ± 1 mm
 X.X = ± 0.25 mm
 X.XX = ± 0.10 mm
 X.XXX = ± 0.01 mm
 ANGLES = $\pm 5^\circ$
 UNLESS STATED

MATERIAL:
 ANNEALED BRASS
 CW614N M TO BS EN 12164
FINISH: 100% TIN OVER NICKEL
S/AREA: mm²

TITLE:
 TERMINAL
DRAWING NUMBER:
 H2101-01 TO H2103-01
 SHT 2 OF 2

HARWIN USA
 TEL: 603 893 5376
 FAX: 603 893 5396
 mis@harwin.com

HARWIN Europe (UK)
 TEL: 023 9231 4545
 FAX: 023 9231 4590
 mis@harwin.co.uk

HARWIN Asia
 TEL: +65 6 779 4909
 FAX: +65 6 779 3868
 mis@harwin.com.sg