

AAV003-10E Current Sensor

Key Features

- For Low Current Detection
- On-Chip Current Strap for Precise Operation
- -80 mA to +80 mA Linear Range
- Sensitivity up to 2 mV/mA
- AC or DC Measurement
- Ultraminiature TDFN Package



Description

The AAV003-10E is a high linearity, extremely low hysteresis GMR current sensor with an on-chip current strap. A GMR bridge sensor element close to the current strap senses the magnetic field created by the current. The GMR sensor element uses a unique, bipolar output, low hysteresis GMR material for excellent accuracy. The four terminals of the bridge sensor are available externally. The output terminals of the bridge provide a bipolar voltage signal proportional to the current through the strap.

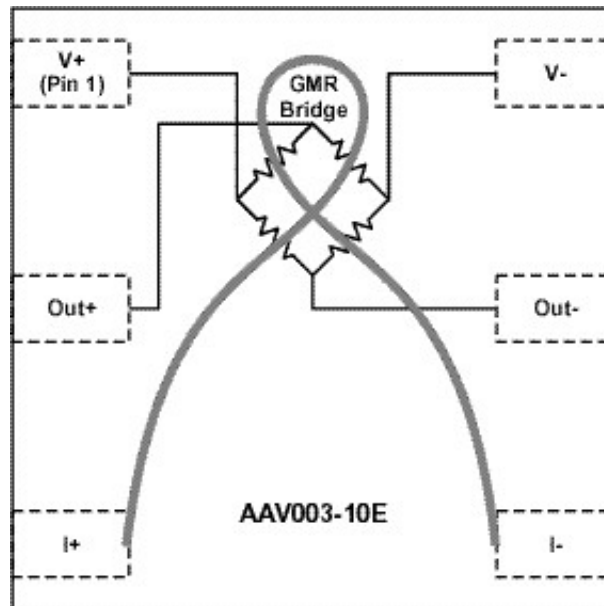

AAV003-10E Functional Diagram

Operation

A representative transfer curve is shown below:

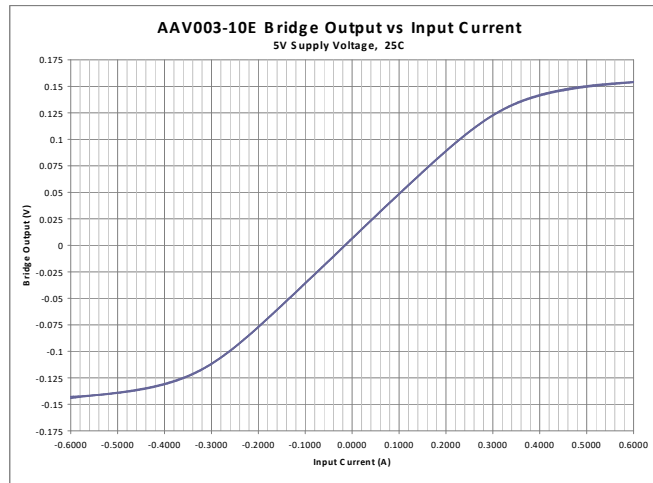

Operating Specifications:

Parameter	Test Conditions	Min.	Typ.	Max.	Units
Nominal Bridge Resistance	25°C	5500	7000	8500	Ohms
Sensitivity	Operating; 5 V Supply, 25°C	0.06	0.08	0.10	mV/V-mA
Frequency Response		100			KHz
Linear Range of Current Measurement	Operating; Full Voltage and Temperature Range	-80		80	mA
Output Linearity	Over Linear Current Range; Full Oper. Temperature Range	99%			
Bridge Electrical Offset	25°C	-4		+4	mV/V
Offset Drift over Full Temperature Range	Zero Current	-1.0		1.0	mV/V
Bridge Supply Voltage				24	Volts
Isolation Voltage	See Note 1	120			V _{RMS}
On-Chip Current Strap Resistance	25°C	0.25		0.35	Ohms
On-Chip Current Strap Resistance Temperature Coefficient			+0.6		%/°C
Temperature Range of Operation	Operating	-40		85	°C
Bridge Resistance Temperature Coeff.	Operating		+0.1		%/°C
Bridge TCOV ²	Operating		-0.21		%/°C

Notes:

- For isolation measurement, the sensor is considered a two terminal device: I₋ and I₊ pins (pins 3 and 4) are shorted, and bridge pins (pins 1, 2, 5, and 6) are shorted.
- TCOV is the percent change in output signal over temperature, with a constant voltage source powering the part.

Absolute Maximum Ratings:

Parameter	Min.	Typ.	Max.	Units
Absolute Maximum Current	-600		600	mA
Bridge Supply Voltage			30	Volts
Storage Temperature	-40		170	°C
Ambient Magnetic Field	Unlimited			

Note: Exceeding Absolute Maximum Ratings may cause permanent damage.

External Magnetic Fields and Hysteresis Effects

The AAV003-10E sensor elements are shielded to make them insensitive to external magnetic fields, however, shielding is not 100% effective, so external fields applied to the sensor should be avoided for the most repeatable, accurate operation.

When exposed to magnetic fields over 50 Oe (5 mT), the characteristic of the sensor can be disturbed, causing a hysteresis effect that will produce a non-linear response. A magnetic field of 50 Oe is a large field that should not be encountered during normal operation. However, in case the sensor is exposed to such a field, a degauss pulse train can be applied to the sensor to restore the original response. The sensor cannot be permanently damaged by any magnetic field, no matter how large and it can always be restored after exposure to a large field with a degauss signal.

This same effect can be observed when a large constant current (>200 mA) is applied to the on-chip current strap, or a smaller constant current (>100 mA) at high temperatures (>85°C). Again in these cases, correct operation of the sensor is restored with a degauss signal.

The degauss signal should consist of at least four current pulses of alternating polarity, with a pulse width of at least 50 μs and an initial current pulse of 600 mA:

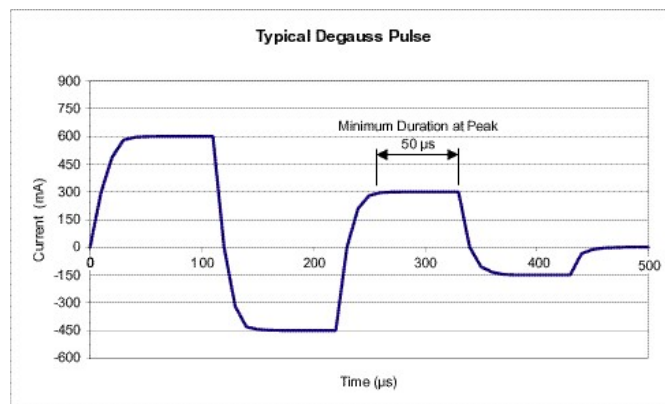

Temperature Characteristics

Typical output over temperature is shown in the graph below:

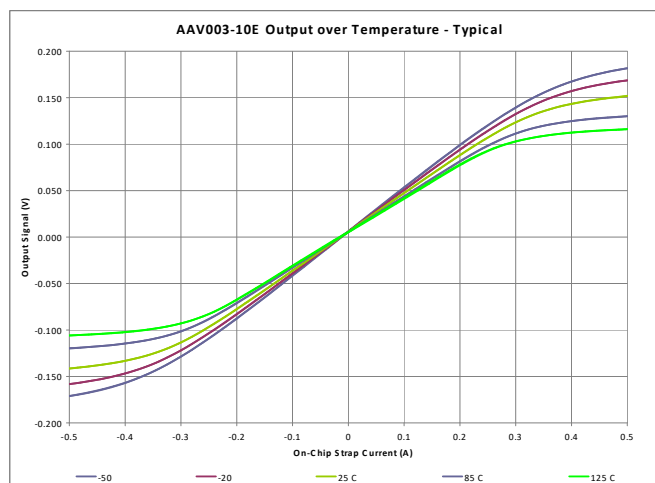

Pinout

The AAV003-10E pinout is as follows:

Pin	Terminal	Description
1	V ₊	Supply Voltage
2	Out ₊	Positive Differential Bridge Output
3	I ₊	Current Terminal 1
4	I ₋	Current Terminal 2
5	Out ₋	Negative Differential Bridge Output
6	V ₋	Ground

Notes:

1. Pins are numbered counterclockwise around the package.
2. Current entering the chip via terminal I₊ and leaving the chip via terminal I₋ produces a positive bridge output.

Package Drawing – TDFN6 2.5 mm x 2.5 mm

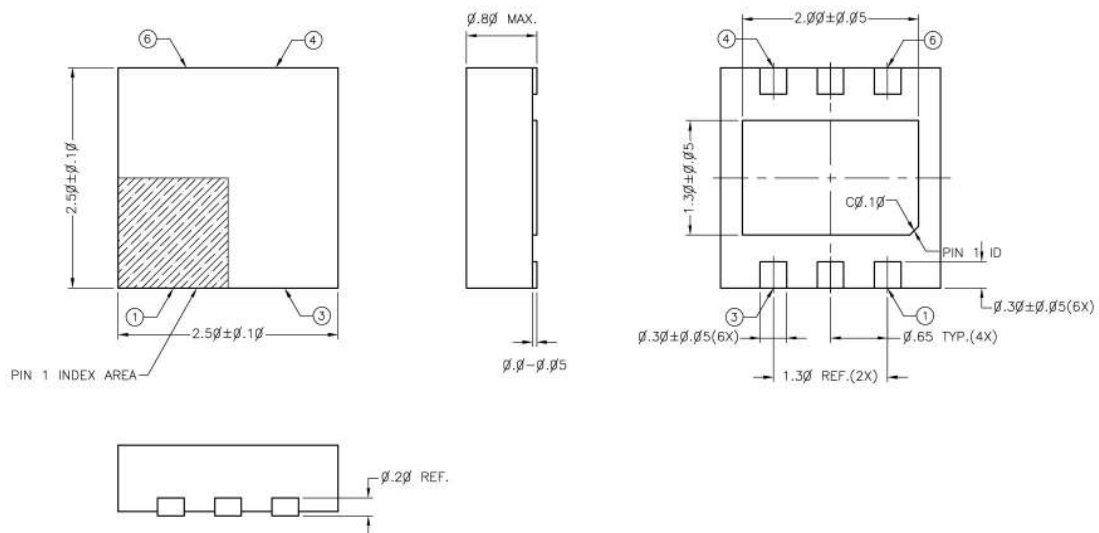

Notes:

- Dimensions in mm.
- TDFN6 package has thermal power dissipation of 320°C/Watt in free air.
- Attaching the package to a circuit board improves thermal performance, especially if the center pad is also soldered to the board.
- The center pad may be left floating or connected to ground.

©NVE Corporation

All rights are reserved. Reproduction in whole or in part is prohibited without the prior written consent of the copyright owner.

Datasheet Limitations

The information and data provided in datasheets shall define the specification of the product as agreed between NVE and its customer, unless NVE and customer have explicitly agreed otherwise in writing. All specifications are based on NVE test protocols. In no event however, shall an agreement be valid in which the NVE product is deemed to offer functions and qualities beyond those described in the datasheet.

Limited Warranty and Liability

Information in this document is believed to be accurate and reliable. However, NVE does not give any representations or warranties, expressed or implied, as to the accuracy or completeness of such information and shall have no liability for the consequences of use of such information.

In no event shall NVE be liable for any indirect, incidental, punitive, special or consequential damages (including, without limitation, lost profits, lost savings, business interruption, costs related to the removal or replacement of any products or rework charges) whether or not such damages are based on tort (including negligence), warranty, breach of contract or any other legal theory.

Right to Make Changes

NVE reserves the right to make changes to information published in this document including, without limitation, specifications and product descriptions at any time and without notice. This document supersedes and replaces all information supplied prior to its publication.

Use in Life-Critical or Safety-Critical Applications

Unless NVE and a customer explicitly agree otherwise in writing, NVE products are not designed, authorized or warranted to be suitable for use in life support, life-critical or safety-critical devices or equipment. NVE accepts no liability for inclusion or use of NVE products in such applications and such inclusion or use is at the customer's own risk. Should the customer use NVE products for such application whether authorized by NVE or not, the customer shall indemnify and hold NVE harmless against all claims and damages.

Applications

Applications described in this datasheet are illustrative only. NVE makes no representation or warranty that such applications will be suitable for the specified use without further testing or modification.

Customers are responsible for the design and operation of their applications and products using NVE products, and NVE accepts no liability for any assistance with applications or customer product design. It is customer's sole responsibility to determine whether the NVE product is suitable and fit for the customer's applications and products planned, as well as for the planned application and use of customer's third party customers. Customers should provide appropriate design and operating safeguards to minimize the risks associated with their applications and products.

NVE does not accept any liability related to any default, damage, costs or problem which is based on any weakness or default in the customer's applications or products, or the application or use by customer's third party customers. The customer is responsible for all necessary testing for the customer's applications and products using NVE products in order to avoid a default of the applications and the products or of the application or use by customer's third party customers. NVE accepts no liability in this respect.

Limiting Values

Stress above one or more limiting values (as defined in the Absolute Maximum Ratings System of IEC 60134) will cause permanent damage to the device. Limiting values are stress ratings only and operation of the device at these or any other conditions above those given in the recommended operating conditions of the datasheet is not warranted. Constant or repeated exposure to limiting values will permanently and irreversibly affect the quality and reliability of the device.

Terms and Conditions of Sale

In case an individual agreement is concluded only the terms and conditions of the respective agreement shall apply. NVE hereby expressly objects to applying the customer's general terms and conditions with regard to the purchase of NVE products by customer.

No Offer to Sell or License

Nothing in this document may be interpreted or construed as an offer to sell products that is open for acceptance or the grant, conveyance or implication of any license under any copyrights, patents or other industrial or intellectual property rights.

Export Control

This document as well as the items described herein may be subject to export control regulations. Export might require a prior authorization from national authorities.

Automotive Qualified Products

Unless the datasheet expressly states that a specific NVE product is automotive qualified, the product is not suitable for automotive use. It is neither qualified nor tested in accordance with automotive testing or application requirements. NVE accepts no liability for inclusion or use of non-automotive qualified products in automotive equipment or applications.

In the event that customer uses the product for design-in and use in automotive applications to automotive specifications and standards, customer (a) shall use the product without NVE's warranty of the product for such automotive applications, use and specifications, and (b) whenever customer uses the product for automotive applications beyond NVE's specifications such use shall be solely at customer's own risk, and (c) customer fully indemnifies NVE for any liability, damages or failed product claims resulting from customer design and use of the product for automotive applications beyond NVE's standard warranty and NVE's product specifications.

Revision History

SB-00-022

Changes

SB-00-022B
Feb 2021

- Changed Isolation voltage.

SB-00-022A
Feb 2012

- Initial Release