

REVISIONS				
P.	LTN	DESCRIPTION	DATE	APVD
1		INITIAL DRAWING.	21JUN2017	JAB ERL

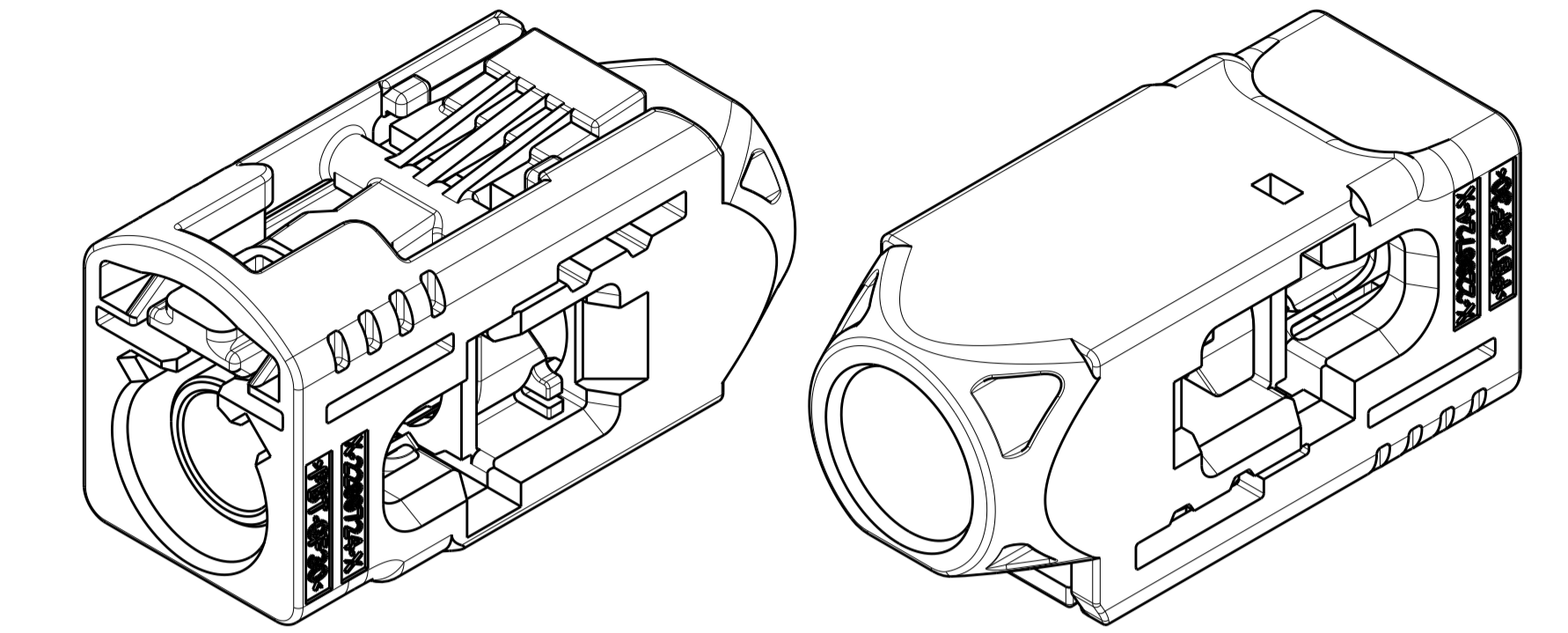

ISOMETRIC VIEWS
SCALE 4:1

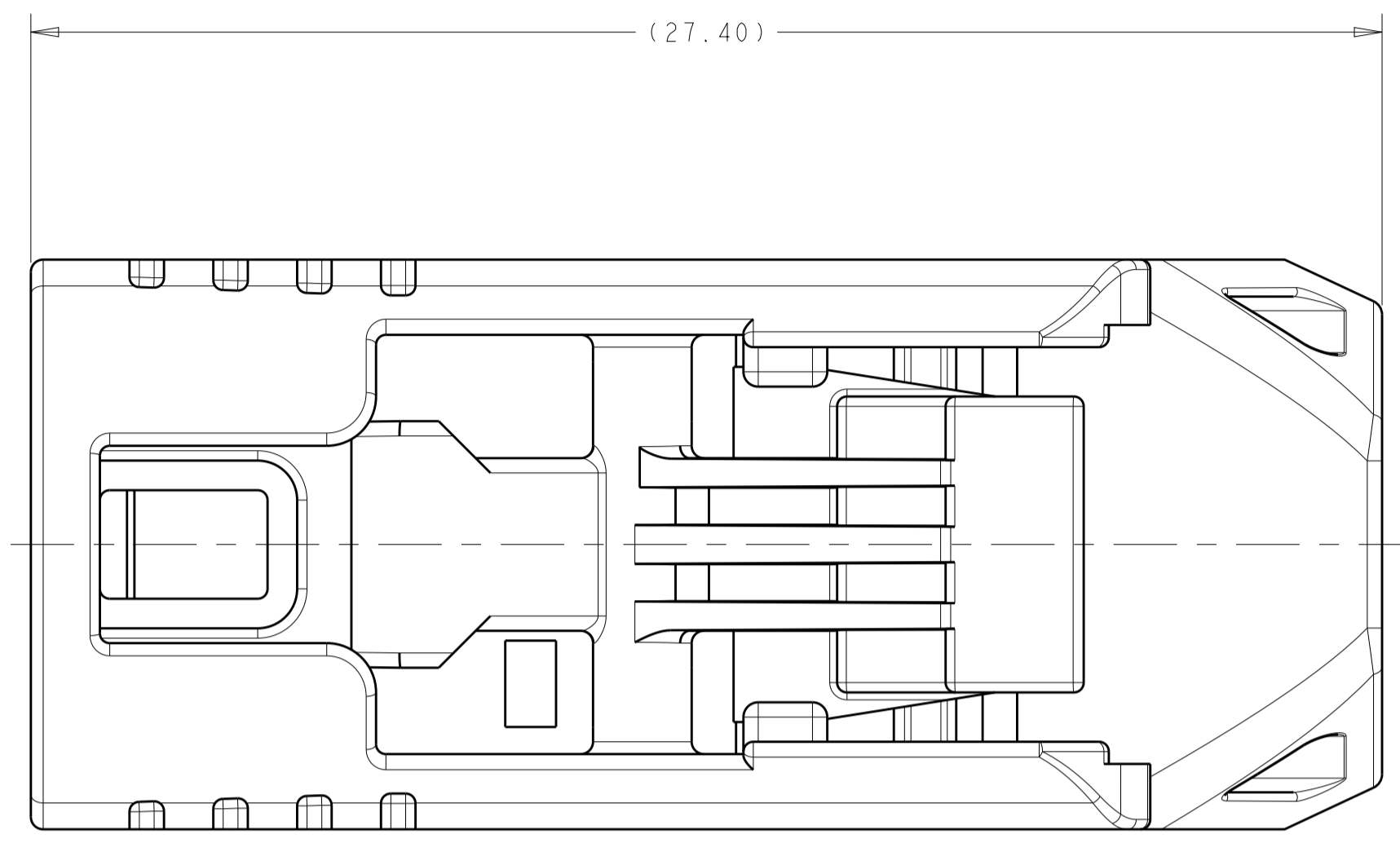
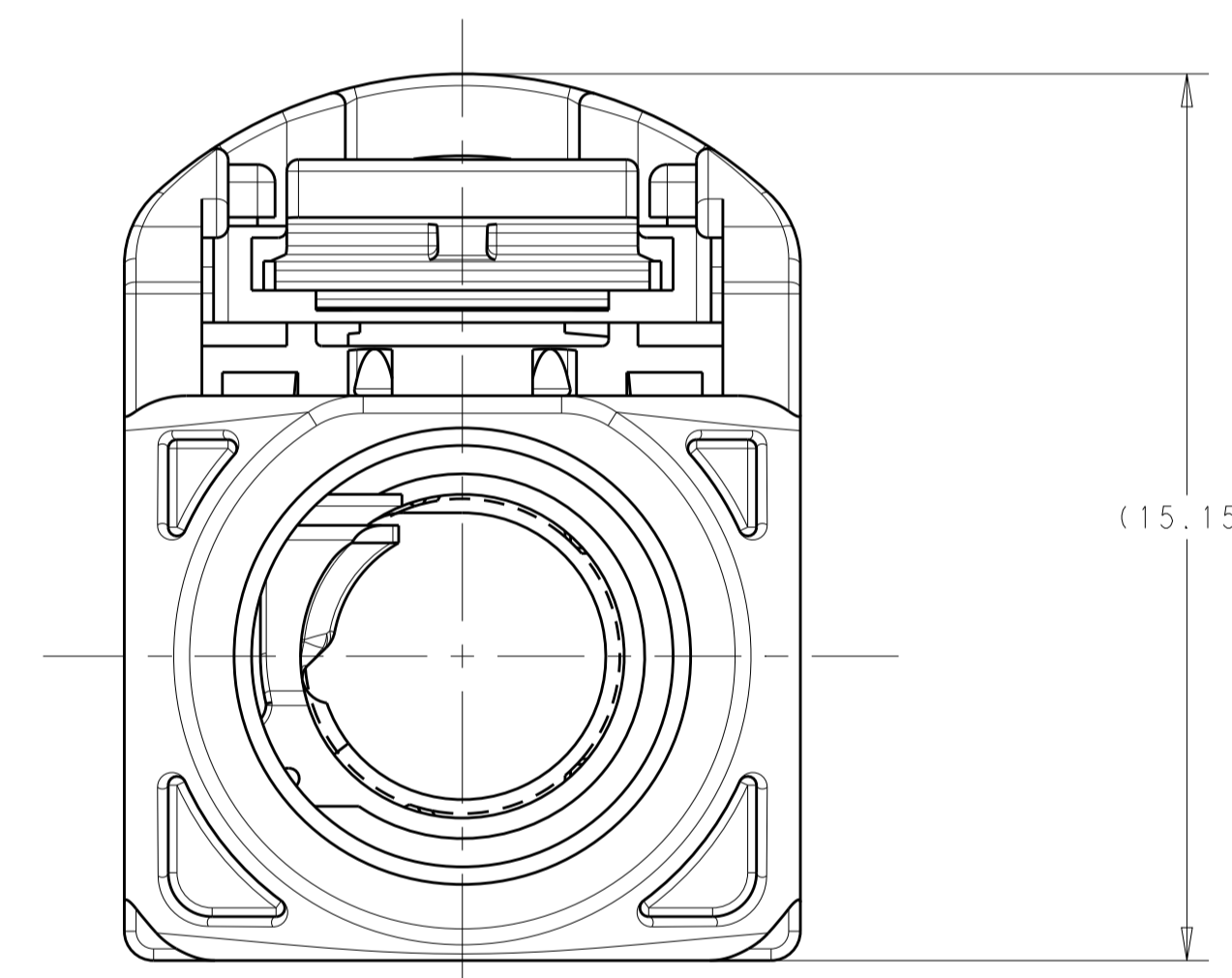
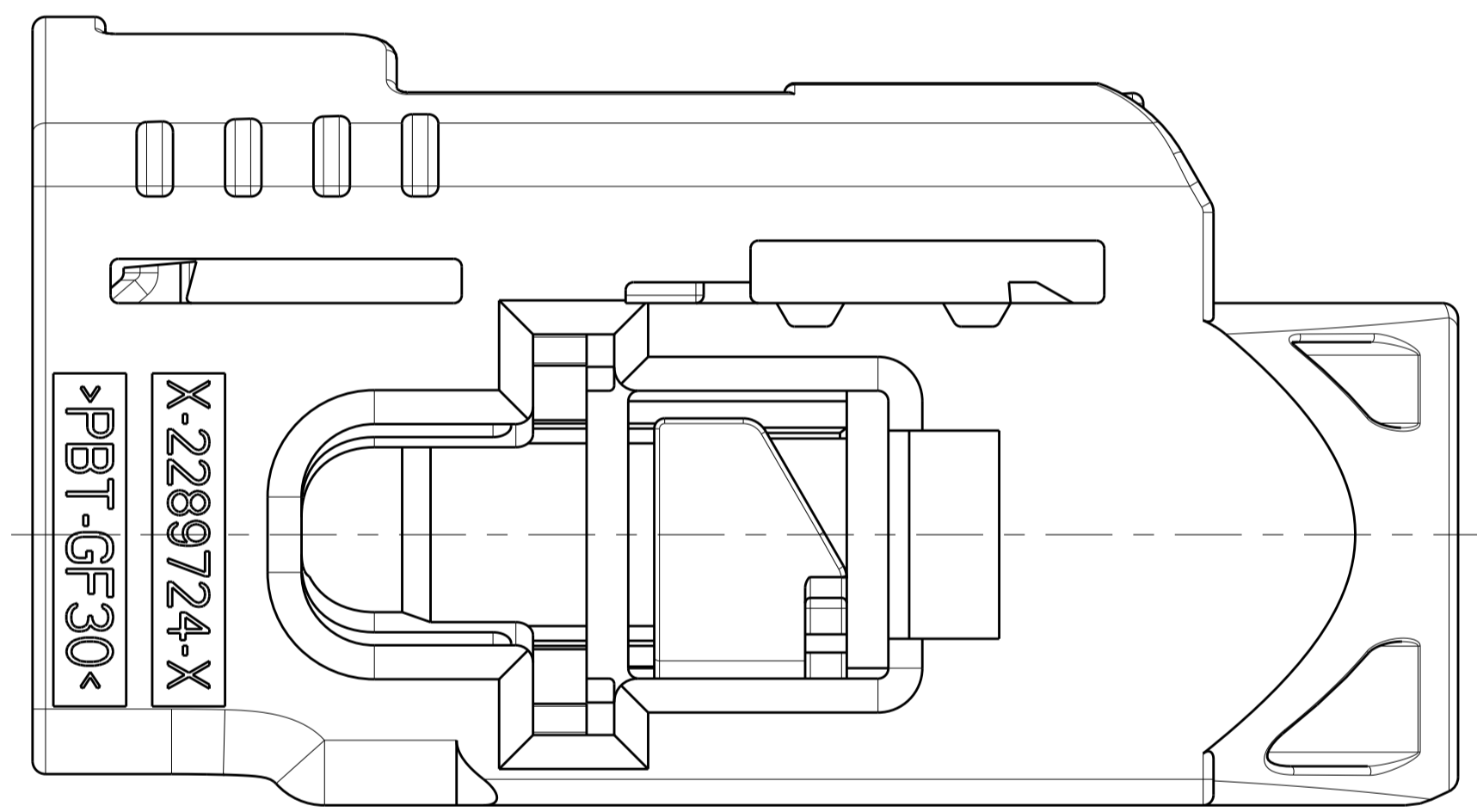
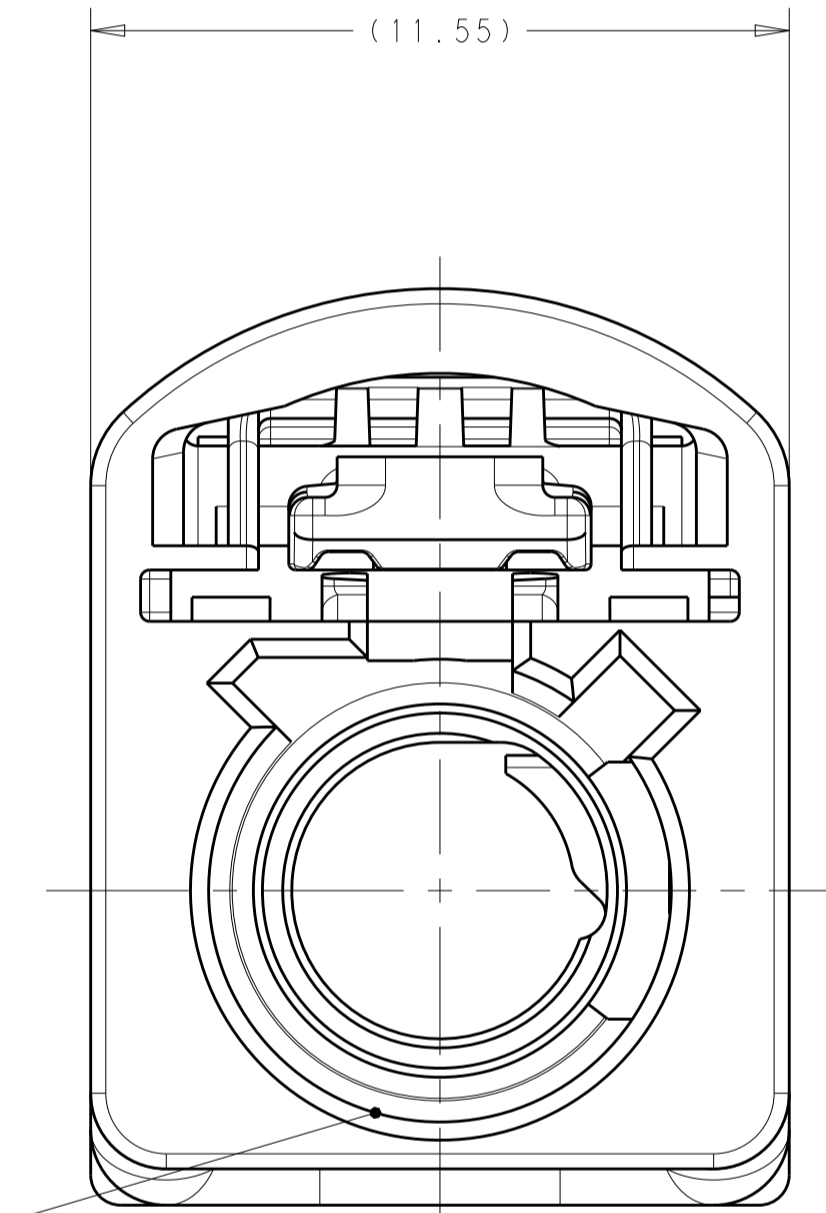

Z	PER DETAIL Z	WATER BLUE	2-2289724-0
N	PER DETAIL N	PASTEL GREEN	1-2289724-3
M	PER DETAIL M	PASTEL ORANGE	1-2289724-2
L	PER DETAIL L	CARMINE RED	1-2289724-1
K	PER DETAIL K	CURRY	1-2289724-0
I	PER DETAIL I	BEIGE	2289724-9
H	PER DETAIL H	HEATHER VIOLET	2289724-8
G	PER DETAIL G	BLUE GREY	2289724-7
F	PER DETAIL F	NUT BROWN	2289724-6
E	PER DETAIL E	LEAF GREEN	2289724-5
D	PER DETAIL D	CLARET VIOLET	2289724-4
C	PER DETAIL C	SIGNAL BLUE	2289724-3
B	PER DETAIL B	CREAM	2289724-2
A	PER DETAIL A	JET BLACK	2289724-1
KEY CODE	KEYING	CODING COLOR	PART NUMBER

- 1. 2289724-1 AS SHOWN.
- MATERIAL, POLYESTER PBT, COLOR SEE TABLE.
- FEMALE INTERFACE PER ISO-20860-1, ISO-20860-2, SAE/USCAR-17, SAE/USCAR-18

THIS PRINT IS
PRELIMINARY
 FOR QUOTING PURPOSES ONLY
 CONTACT PRODUCT ENGINEERING
 BEFORE USING THIS PRINT

THIS DRAWING IS A CONTROLLED DOCUMENT.

DIMENSIONS:	TOLERANCES UNLESS OTHERWISE SPECIFIED:	APVD	DATE
mm	0 PLC ± 1 PLC ± 2 PLC ± 3 PLC ± 4 PLC ± ANGLES ±	J. A. BAKER E. R. LOVE E. R. LOVE	21JUN2017 28JUL2017 28JUL2017
MATERIAL	FINISH	PRODUCT SPEC	NAME
		108-32137	FEMALE HOUSING, 1 POSITION, FAKRA
		114-32145	APPLICATION SPEC
		WEIGHT	SIZE
			A1
		CUSTOMER DRAWING	SCALE 8:1 SHEET 1 OF 3 REV 1

TE Connectivity

THIS DRAWING IS UNPUBLISHED. RELEASED FOR PUBLICATION
 COPYRIGHT copyright.dbr- ALL RIGHTS RESERVED.

REVISIONS				
P.	LTN	DESCRIPTION	DATE	APP'D
-	-	SEE SHEET 1	-	-

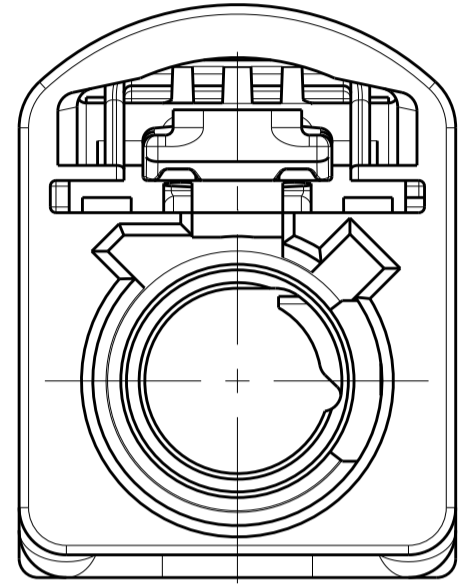

DETAIL A
SCALE 5:1

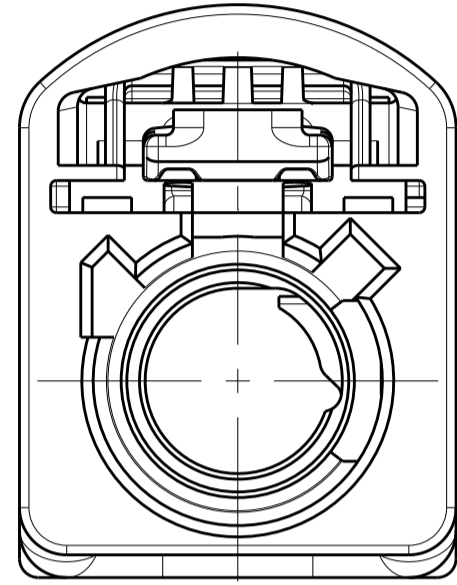

DETAIL B
SCALE 5:1

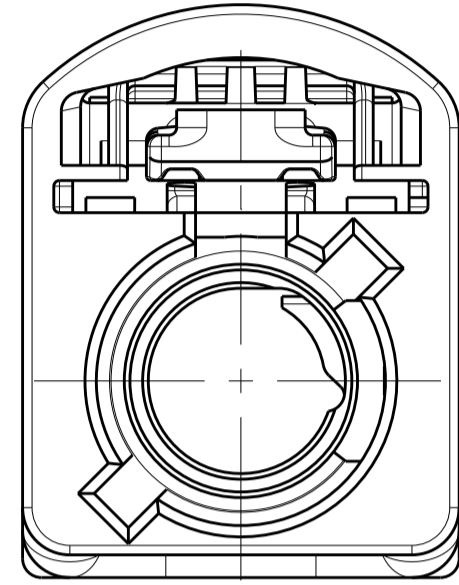

DETAIL C
SCALE 5:1

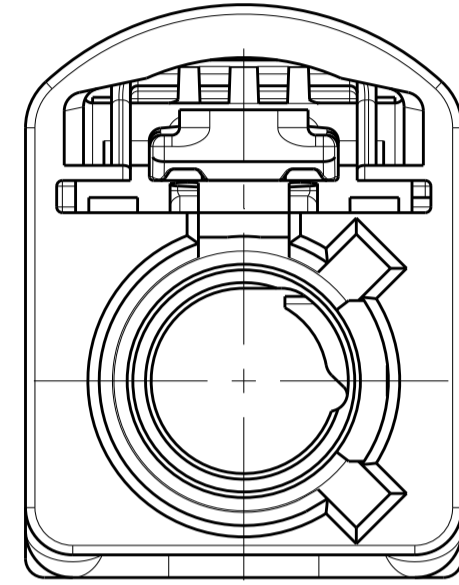

DETAIL D
SCALE 5:1

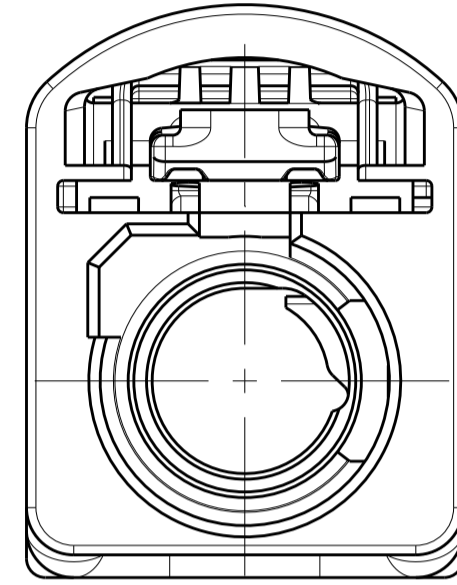

DETAIL E
SCALE 5:1

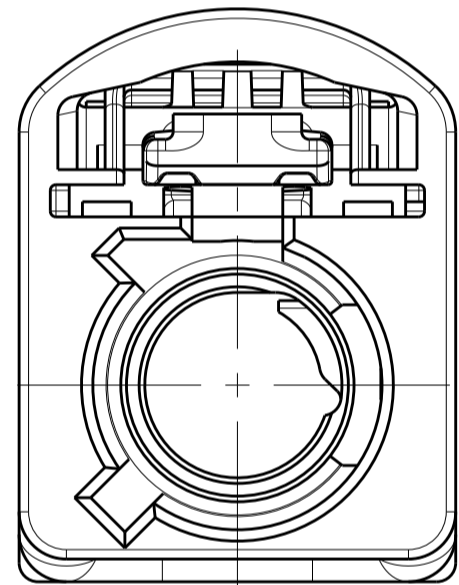

DETAIL F
SCALE 5:1

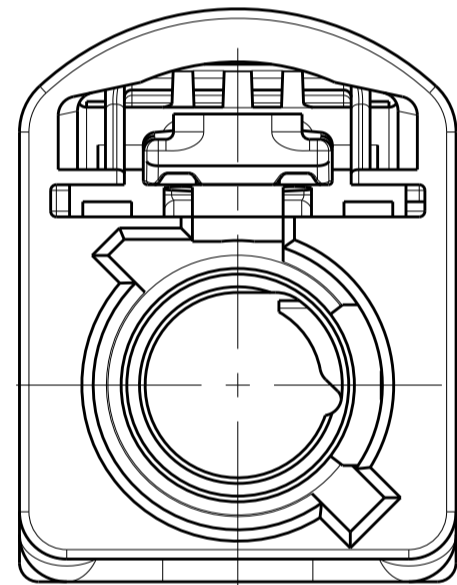

DETAIL G
SCALE 5:1

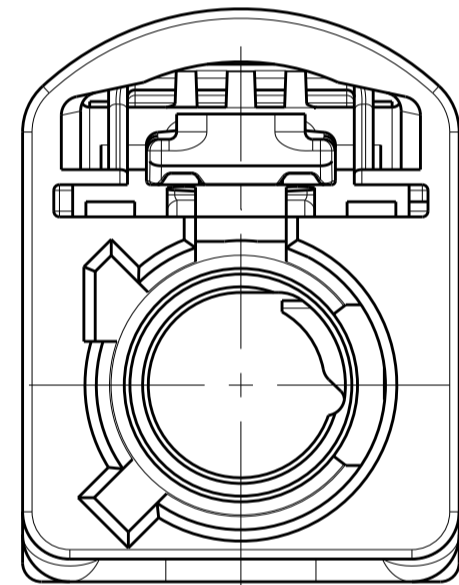

DETAIL H
SCALE 5:1

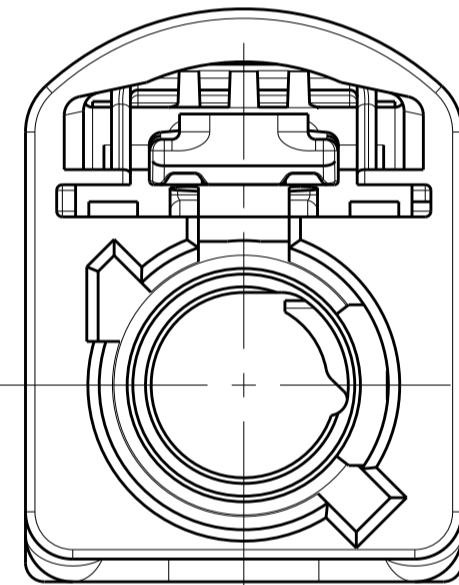

DETAIL I
SCALE 5:1

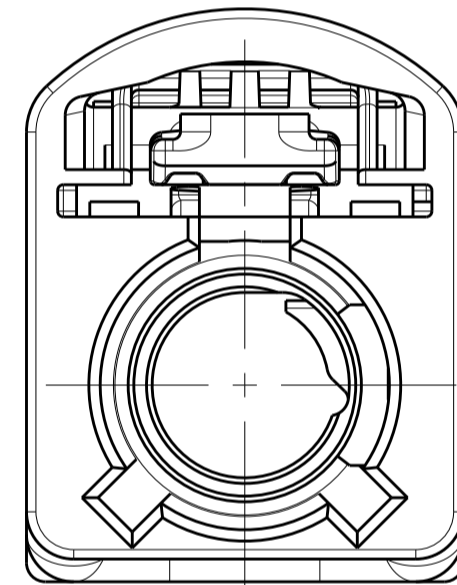

DETAIL K
SCALE 5:1

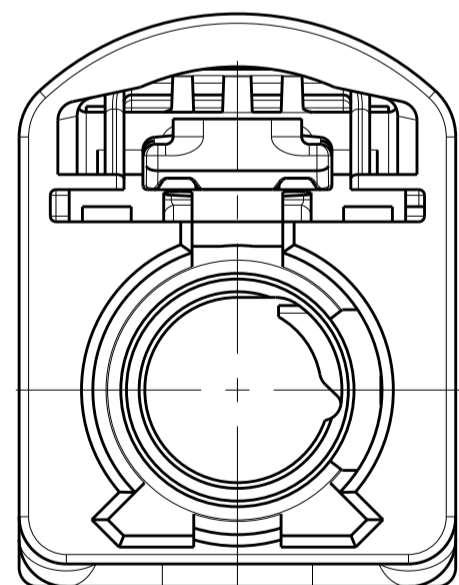

DETAIL L
SCALE 5:1

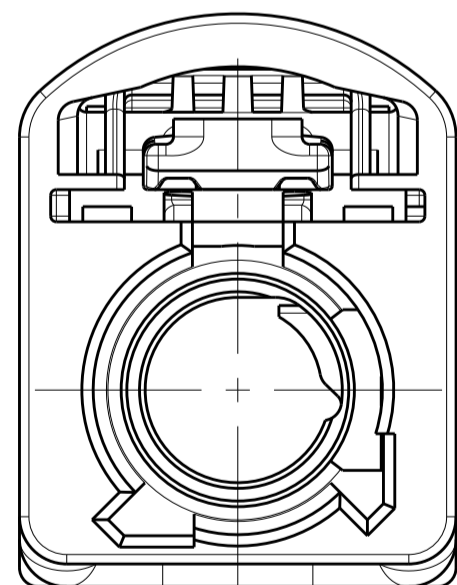

DETAIL M
SCALE 5:1

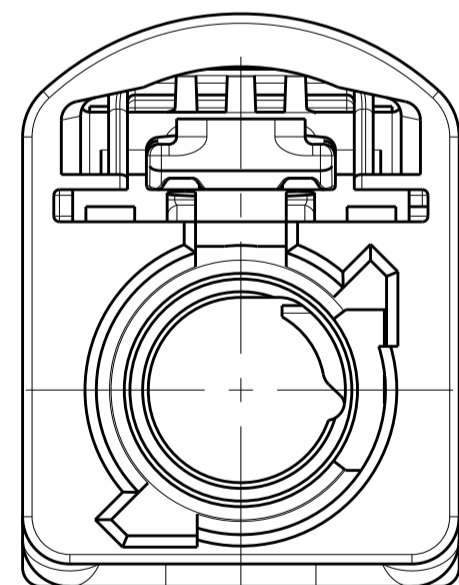

DETAIL N
SCALE 5:1

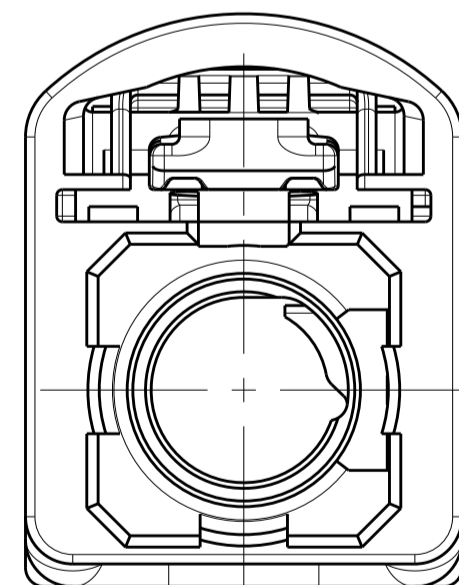

DETAIL Z
SCALE 5:1

THIS PRINT IS
PRELIMINARY
 FOR QUOTING PURPOSES ONLY
 CONTACT PRODUCT ENGINEERING
 BEFORE USING THIS PRINT

THIS DRAWING IS A CONTROLLED DOCUMENT.		DWN J.A. BAKER 21JUN2017 CHK E.R. LOVE 28JUL2017 APVD E.R. LOVE 28JUL2017	
DIMENSIONS: mm 	TOLERANCES UNLESS OTHERWISE SPECIFIED: 0 PLC ± 1 PLC ± 2 PLC ± 3 PLC ± 4 PLC ± ANGLES ±	NAME FEMALE HOUSING, 1 POSITION, FAKRA PRODUCT SPEC 108-32137 APPLICATION SPEC 114-32145 WEIGHT - CUSTOMER DRAWING	
MATERIAL	FINISH	SIZE A1 CAGE CODE - DRAWING NO. C=2289724 SCALE 8:1 SHEET 2 OF 3 REV 1	RESTRICTED TO

THIS DRAWING IS UNPUBLISHED. RELEASED FOR PUBLICATION
 © COPYRIGHT copyright_d81e- ALL RIGHTS RESERVED.

REVISIONS				
REV	LTN	DESCRIPTION	DATE	APVD
-	-	SEE SHEET 1	-	-

2289724-C						STOCK DISPOSITION			
FEMALE HOUSING, 1 POSITION, FAKRA -						A: CONTINUE AS IS		D: USE OLD FIRST	
REVISION HISTORY						B: REWORK		E: PARTS TO CONFORM	
						C: SCRAP		F: OTHER	
DATE	REV	CHANGES	REASON	APPROVAL	INVENTORY (A,B,C,D,E,F)	WORK IN PROCESS (A,B,C,F)	SUPPLIER ORDERS (A,E,F)	OPEN CUST ORDERS (A,E,F)	
06APR2017	1	PROPOSED.	DEVELOPMENT ENGINEERING.	ERL	-	-	-	-	
-	-	-	-	-	-	-	-	-	
-	-	-	-	-	-	-	-	-	
-	-	-	-	-	-	-	-	-	
-	-	-	-	-	-	-	-	-	
-	-	-	-	-	-	-	-	-	
-	-	-	-	-	-	-	-	-	
-	-	-	-	-	-	-	-	-	
-	-	-	-	-	-	-	-	-	
-	-	-	-	-	-	-	-	-	
-	-	-	-	-	-	-	-	-	
-	-	-	-	-	-	-	-	-	
-	-	-	-	-	-	-	-	-	
-	-	-	-	-	-	-	-	-	
-	-	-	-	-	-	-	-	-	
-	-	-	-	-	-	-	-	-	
-	-	-	-	-	-	-	-	-	
-	-	-	-	-	-	-	-	-	

THIS PRINT IS
PRELIMINARY
 FOR QUOTING PURPOSES ONLY
 CONTACT PRODUCT ENGINEERING
 BEFORE USING THIS PRINT

THIS DRAWING IS A CONTROLLED DOCUMENT.		DWN J.A.BAKER 21JUN2017 CHK E.R.LOVE 28JUL2017 APVD E.R.LOVE 28JUL2017	 TE Connectivity
DIMENSIONS: mm	TOLERANCES UNLESS OTHERWISE SPECIFIED: 0 PLC ± 1 PLC ± 2 PLC ± 3 PLC ± 4 PLC ± ANGLES ±	NAME FEMALE HOUSING, 1 POSITION, FAKRA PRODUCT SPEC - 108-32137 APPLICATION SPEC - 114-32145	
MATERIAL - FINISH -	WEIGHT - CUSTOMER DRAWING	SIZE A1 CAGE CODE - DRAWING NO. ©=2289724 RESTRICTED TO -	SCALE 8:1 SHEET 3 OF 3 REV 1