

# Single Synchronous Buck Controller

## General Description

The RT8202/A/B PWM controller provides high efficiency, excellent transient response, and high DC output accuracy needed for stepping down high voltage batteries to generate low voltage CPU core, I/O, and chipset RAM supplies in notebook computers.

The constant on-time PWM control scheme handles wide input/output voltage ratios with ease and provides 100ns “instant-on” response to load transients while maintaining a relatively constant switching frequency.

The RT8202/A/B achieves high efficiency at a reduced cost by eliminating the current sense resistor found in traditional current mode PWMs. Efficiency is further enhanced by its ability to drive very large synchronous rectifier MOSFETs. The buck conversion allows this device to directly step down high voltage batteries for the highest possible efficiency. The RT8202/A/B is intended for CPU core, chipset, DRAM, or other low voltage supplies as low as 0.75V. RT8202 is available in WQFN-16L 4x4, RT8202A is available in WQFN-16L 3x3 and RT8202B is available in WQFN-14L 3.5x3.5 packages.

## Ordering Information

- RT8202/A/B □ □
- Package Type
    - QW : WQFN-16L 4x4 (W-Type) (RT8202)
    - QW : WQFN-16L 3x3 (W-Type) (RT8202A)
    - QW : WQFN-14L 3.5x3.5 (W-Type) (RT8202B)
  - Operating Temperature Range
    - P : Pb Free with Commercial Standard
    - G : Green (Halogen Free with Commercial Standard)

Note :

- Richtek Pb-free and Green products are :
- ▶ RoHS compliant and compatible with the current requirements of IPC/JEDEC J-STD-020.
  - ▶ Suitable for use in SnPb or Pb-free soldering processes.

## Marking Information

For marking information, contact our sales representative directly or through a Richtek distributor located in your area, otherwise visit our website for detail.

## Features

- Ultra-High Efficiency
- Resistor Programmable Current Limit by Low Side  $R_{DS(ON)}$  Sense (Lossless Limit) or Sense Resistor (High Accuracy)
- Quick Load Step Response within 100ns
- 1%  $V_{OUT}$  Accuracy over Line and Load
- Adjustable 0.75V to 3.3V Output Range
- 4.5V to 26V Battery Input Range
- Resistor Programmable Frequency
- Over/Under Voltage Protection
- 2 Steps Current Limit During Soft-Start
- Drives Large Synchronous-Rectifier FETs
- Power Good Indicator
- RoHS Compliant and 100% Lead (Pb)-Free

## Applications

- Notebook Computers
- CPU Core Supply
- Chipset/RAM Supply as Low as 0.75V

## Pin Configurations

(TOP VIEW)

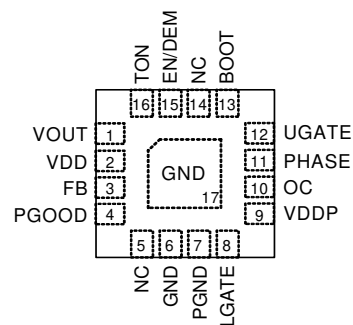

WQFN-16L 4x4/WQFN-16L 3x3

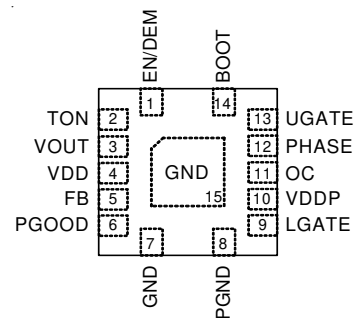

WQFN-14L 3.5x3.5

Typical Application Circuit

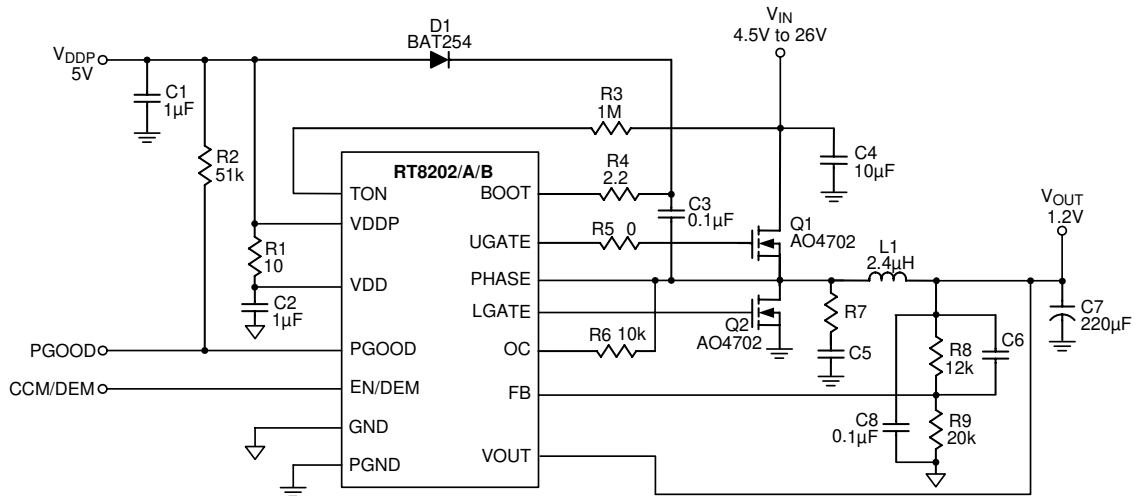

Functional Pin Description

Pin No.		Pin Name	Pin Function
RT8202/A	RT8202B		
1	3	VOUT	VOUT Sense Input. Connect to the output of PWM converter. VOUT is an input of the PWM controller.
2	4	VDD	Analog Supply Voltage Input for the internal analog integrated circuit. Bypass to GND with a 1µF ceramic capacitor.
3	5	FB	VOUT Feedback Input. Connect FB to a resistor voltage divider from VOUT to GND to adjust the output from 0.75V to 3.3V.
4	6	PGOOD	Power Good Signal Open-Drain Output of PWM Converter. This pin will be pulled high when the output voltage is within the target range.
5, 14	--	NC	No Internal Connection.
6, Exposed Pad (17)	7, Exposed Pad (15)	GND	Ground for Analog Circuitry. The exposed pad must be soldered to a large PCB and connected to GND for maximum power dissipation.
7	8	PGND	Power Ground.
8	9	LGATE	Low side N-MOSFET Gate-Drive Output for PWM. This pin swings between GND and VDDP.
9	10	VDDP	VDDP is the gate driver supply for the external MOSFETs. Bypass to GND with a 1µF ceramic capacitor.
10	11	OC	PWM Current Limit Setting and sense. Connect a resistor between OC to PHASE for current limit setting.
11	12	PHASE	Inductor Connection. This pin is not only the zero-current-sense input for the PWM converter, but also the UGATE high side gate driver return.
12	13	UGATE	High Side N-MOSFET Floating Gate-Drive Output for the PWM converter. This pin swings between PHASE and BOOT.
13	14	BOOT	Boost Capacitor Connection for PWM Converter. Connect an external ceramic capacitor to PHASE and an external diode to VDDP.
15	1	EN/DEM	PWM Enable and Operation Mode Selection Input. Connect to VDD for diode-emulation mode, connect to GND for shutdown mode and floating the pin for CCM mode.
16	2	TON	VIN Sense Input. Connect to VIN through a resistor. TON is an input of the PWM controller.

Function Block Diagram

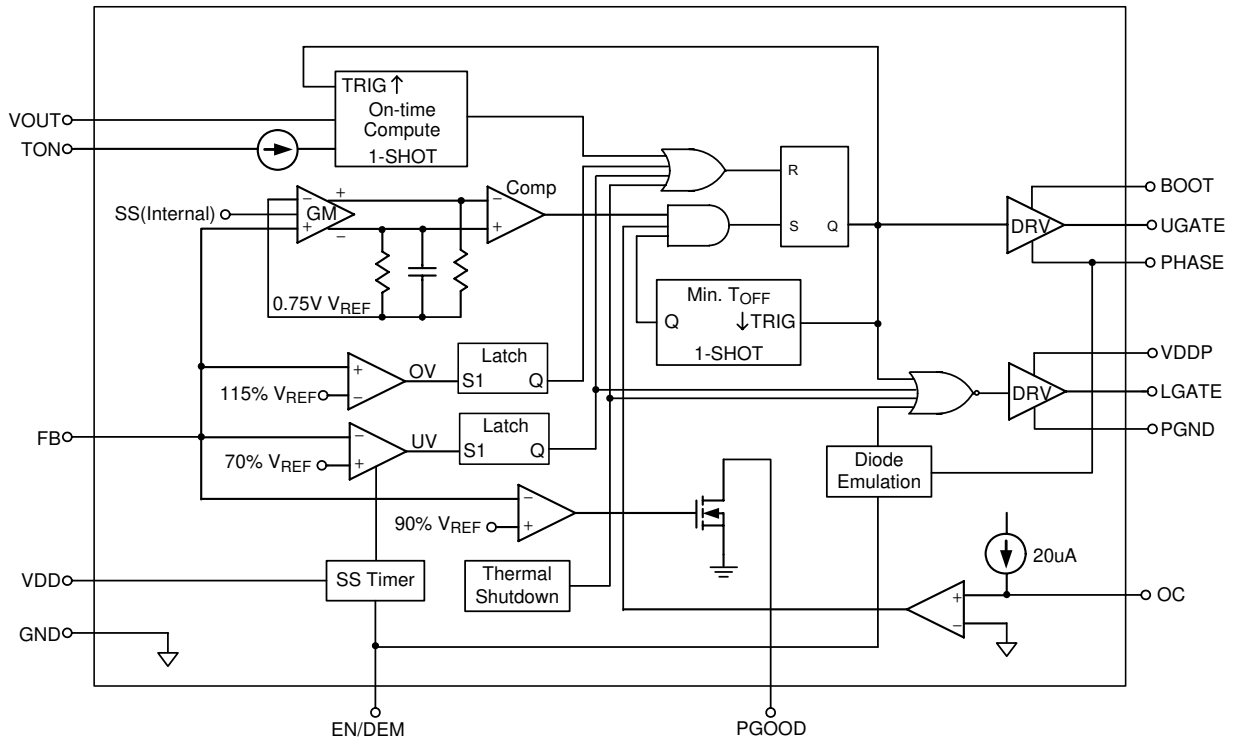

## Absolute Maximum Ratings (Note 1)

• Input Voltage, TON to GND	-----	-0.3V to 32V
• BOOT to GND	-----	-0.3V to 38V
• PHASE to BOOT	-----	-6V to 0.3V
• VDD, VDDP, VOUT, EN/DEM, FB, PGOOD to GND	-----	-0.3V to 6V
• UGATE to PHASE	-----	-0.3V to 6V
• OC to GND	-----	-0.3V to 32V
• LGATE to GND	-----	-0.3V to 6V
• PGND to GND	-----	-0.3V to 0.3V
• Power Dissipation, $P_D$ @ $T_A = 25^\circ\text{C}$		
WQFN-16L 4x4	-----	1.852W
WQFN-16L 3x3	-----	1.471W
WQFN-14L 3.5x3.5	-----	1.667W
• Package Thermal Resistance (Note 2)		
WQFN-16L 4x4, $\theta_{JA}$	-----	54°C/W
WQFN-16L 4x4, $\theta_{JC}$	-----	7°C/W
WQFN-16L 3x3, $\theta_{JA}$	-----	68°C/W
WQFN-16L 3x3, $\theta_{JC}$	-----	7.5°C/W
WQFN-14L 3.5x3.5, $\theta_{JA}$	-----	60°C/W
WQFN-14L 3.5x3.5, $\theta_{JC}$	-----	7°C/W
• Lead Temperature (Soldering, 10 sec.)	-----	260°C
• Junction Temperature	-----	150°C
• Storage Temperature Range	-----	-65°C to 150°C
• ESD Susceptibility (Note 3)		
HBM (Human Body Mode)	-----	2kV
MM (Machine Mode)	-----	200V

## Recommended Operating Conditions (Note 4)

• Input Voltage, $V_{IN}$	-----	4.5V to 26V
• Supply Voltage, $V_{DD}$ , $V_{DDP}$	-----	4.5V to 5.5V
• Junction Temperature Range	-----	-40°C to 125°C
• Ambient Temperature Range	-----	-40°C to 85°C

## Electrical Characteristics

( $V_{DD} = V_{DDP} = 5V$ ,  $V_{IN} = 15V$ ,  $V_{OUT} = 1.25V$ ,  $EN/DEM = V_{DD}$ ,  $R_{TON} = 1M\Omega$ ,  $T_A = 25^\circ\text{C}$ , unless otherwise specified)

Parameter	Symbol	Test Conditions	Min	Typ	Max	Unit
<b>PWM Controller</b>						
Quiescent Supply Current		$V_{DD} + V_{DDP}$ , $FB = 0.8V$	--	--	1250	$\mu\text{A}$
TON Operating Current		$R_{TON} = 1M$	--	15	--	$\mu\text{A}$
Shutdown Current	ISHDN	$V_{DD} + V_{DDP}$	--	1	10	$\mu\text{A}$
		TON	--	1	5	$\mu\text{A}$
		$EN/DEM = 0V$	-10	-1	--	$\mu\text{A}$

*To be continued*

Parameter	Symbol	Test Conditions	Min	Typ	Max	Unit
FB Reference Voltage	V <sub>FB</sub>	V <sub>DD</sub> = 4.5 to 5.5V	0.742	0.75	0.758	V
FB Input Bias Current		FB = 0.75V	-1	0.1	1	μA
Output Voltage Range	V <sub>OUT</sub>		0.75	--	3.3	V
On-Time		V <sub>IN</sub> = 15V, V <sub>OUT</sub> = 1.25V, R <sub>TON</sub> = 1M	267	334	401	ns
Minimum Off-Time			250	400	550	ns
V <sub>OUT</sub> Shutdown Discharge Resistance		EN/DEM = GND	--	20	--	Ω
<b>Current Sensing</b>						
ILIM Source Current		LGATE = High	18	20	22	μA
Current Comparator Offset		GND – OC	-10	--	10	mV
Current Limit Setting Range	R <sub>LIM</sub>		2.5	--	10	kΩ
Zero Crossing Threshold		GND – PHASE, EN/DEM = 5V	-10	--	5	mV
<b>Fault Protection</b>						
Current Limit Sense Voltage	V <sub>RILIM</sub>	GND – PHASE, R <sub>LIM</sub> = 2.5k	35	50	65	mV
		GND – PHASE, R <sub>LIM</sub> = 10k	170	200	230	mV
Output UV Threshold			60	70	80	%
OVP Threshold		With respect to error comparator threshold	10	15	20	%
OV Fault Delay		FB forced above OV threshold	--	20	--	μs
VDD UVLO Threshold		Rising edge, Hysteresis = 20mV, PWM disabled below this level	4.1	4.3	4.5	V
Soft-Start Ramp Time		From EN high to internal V <sub>REF</sub> reach 0.71V (0→95%)	--	1.35	--	ms
UV Blank Time		From EN signal going high	--	3.1	--	ms
Thermal Shutdown			--	155	--	°C
Thermal Shutdown Hysteresis			--	10	--	°C
<b>Driver On-Resistance</b>						
UGATE Driver Pull Up		BOOT – PHASE = 5V	--	1.5	5	Ω
UGATE Driver Sink	R <sub>UGATEsk</sub>	BOOT – PHASE = 5V	--	1.5	5	Ω
LGATE Driver Pull Up		LGATE, High State (Source)	--	1.5	5	Ω
LGATE Driver Pull Down		LGATE, Low State (Sink)	--	0.6	2.5	Ω
UGATE Driver Source/Sink Current		UGATE – PHASE = 2.5V, BOOT – PHASE = 5V	--	1	--	A
LGATE Driver Source Current		LGATE forced to 2.5V	--	1	--	A
LGATE Driver Sink Current		LGATE forced to 2.5V	--	3	--	A
Dead Time		LGATE Rising (PHASE = 1.5V)	--	30	--	ns
		UGATE Rising	--	30	--	

*To be continued*

Parameter	Symbol	Test Conditions	Min	Typ	Max	Unit
<b>Logic I/O</b>						
EN/DEM Logic Low Voltage			--	--	0.8	V
EN/DEM Logic High Voltage			2.9	--	--	V
EN/DEM Floating Voltage		EN/DEM Open	--	2	--	V
Logic Input Current		EN/DEM = V <sub>DD</sub>	--	1	5	μA
		EN/DEM = 0	-5	-1	--	
<b>PGOOD (upper side threshold decide by OV threshold)</b>						
Trip Threshold (Falling)		Measured at FB, with respect to reference, no load. Hysteresis = 3%	-13	-10	-7	%
Fault Propagation Delay		Falling edge, FB forced below PGOOD trip threshold	--	2.5	--	μs
Output Low Voltage		I <sub>SINK</sub> = 1mA	--	--	0.4	V
Leakage Current		High state, forced to 5.0V	--	--	1	μA

**Note 1.** Stresses listed as the above “Absolute Maximum Ratings” may cause permanent damage to the device. These are for stress ratings. Functional operation of the device at these or any other conditions beyond those indicated in the operational sections of the specifications is not implied. Exposure to absolute maximum rating conditions for extended periods may remain possibility to affect device reliability.

**Note 2.**  $\theta_{JA}$  is measured in the natural convection at  $T_A = 25^\circ\text{C}$  on a high effective four layers thermal conductivity test board of JEDEC 51-7 thermal measurement standard. The case point of  $\theta_{JC}$  is on the expose pad for the WQFN package.

**Note 3.** Devices are ESD sensitive. Handling precaution is recommended.

**Note 4.** The device is not guaranteed to function outside its operating conditions.

**Typical Operating Characteristics**

**Efficiency vs. Output Current**

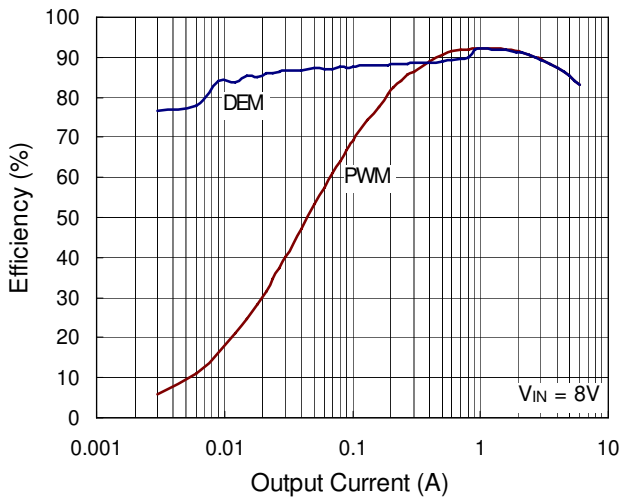

**Switching Frequency vs. Output Current**

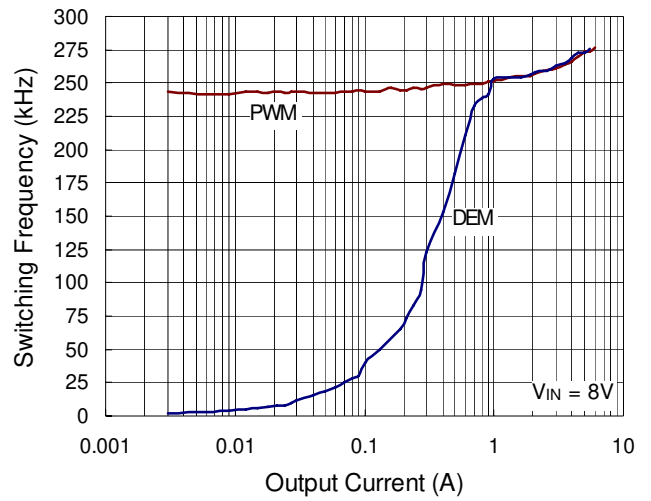

**Efficiency vs. Output Current**

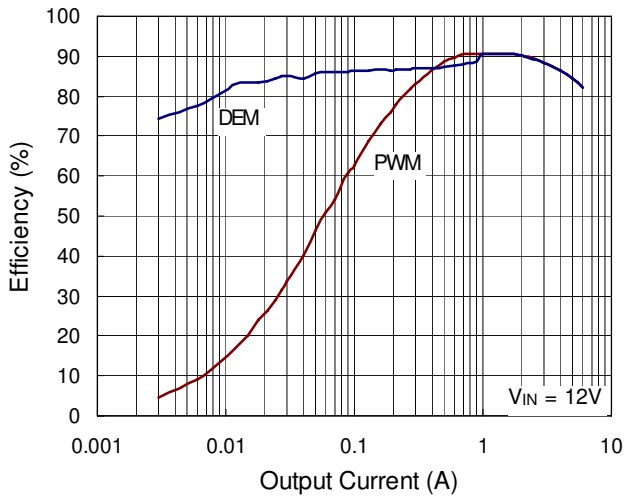

**Switching Frequency vs. Output Current**

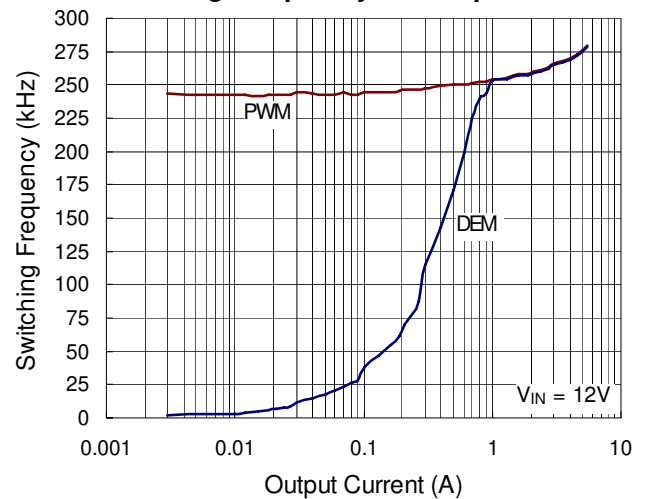

**Efficiency vs. Output Current**

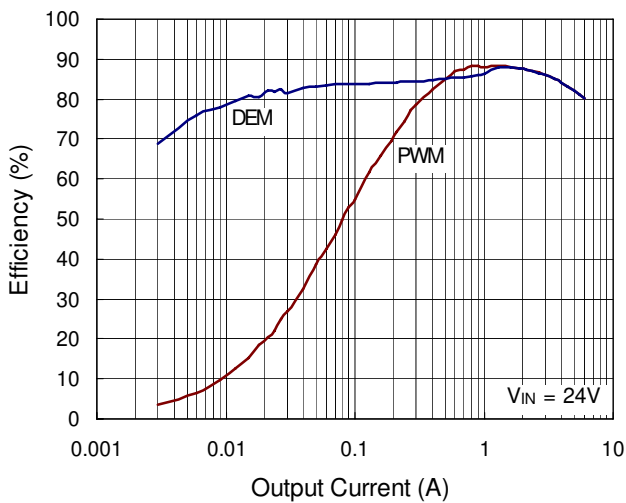

**Switching Frequency vs. Output Current**

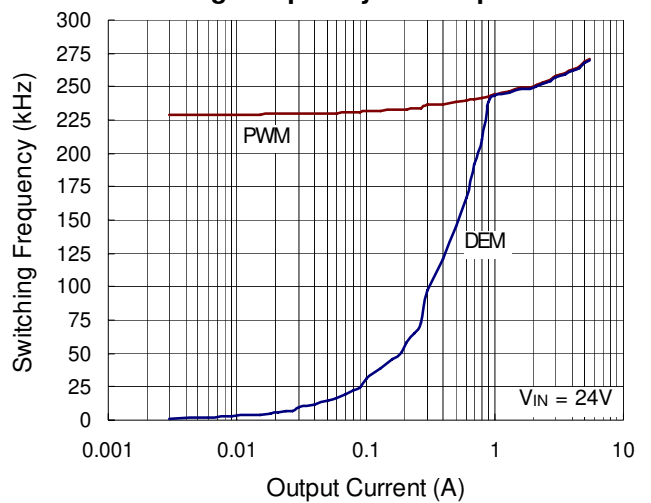

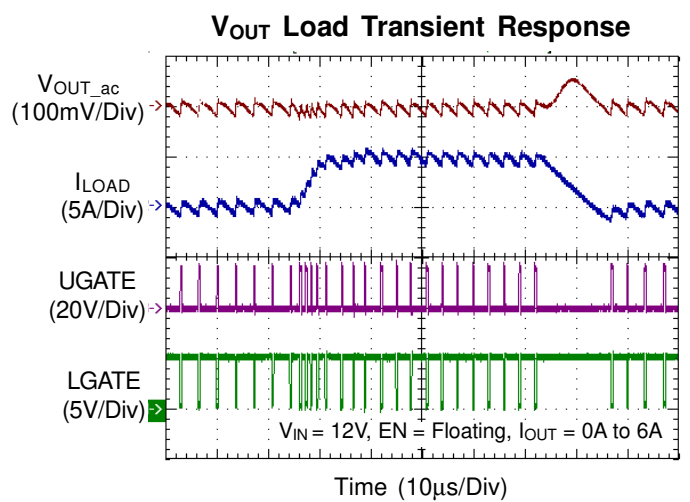
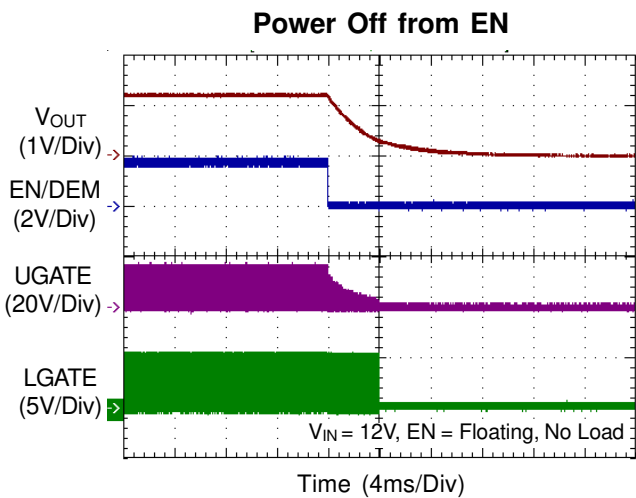
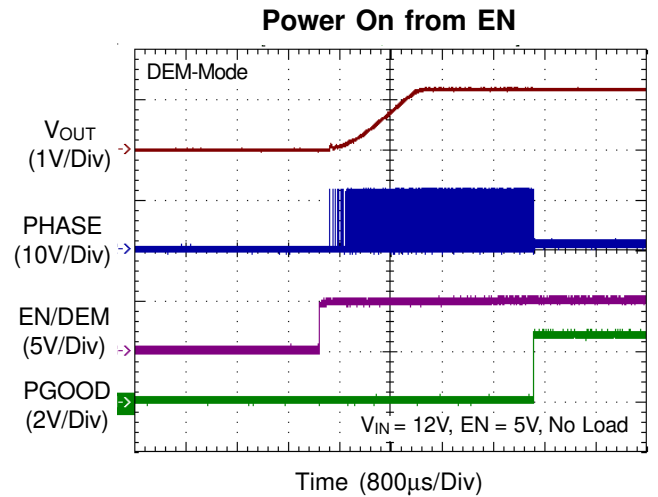
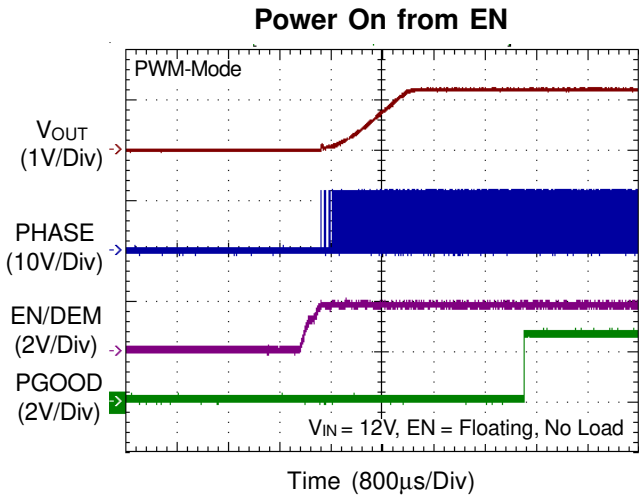
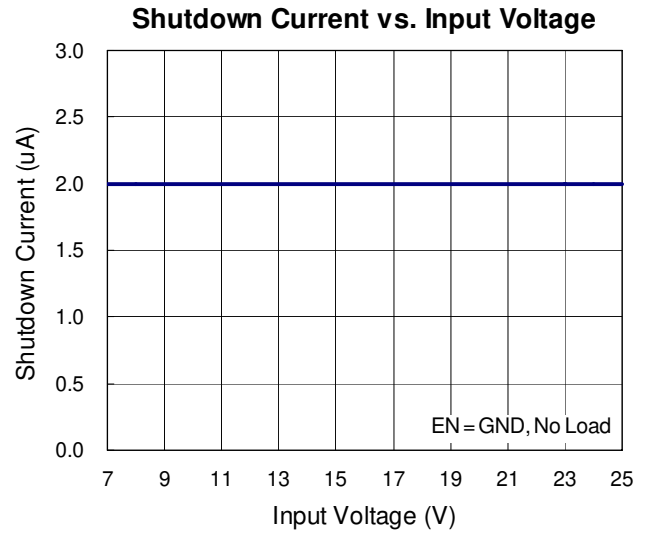
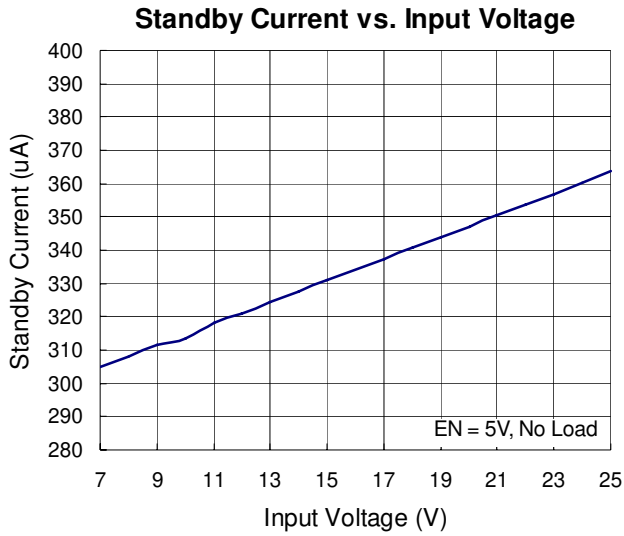



OVP

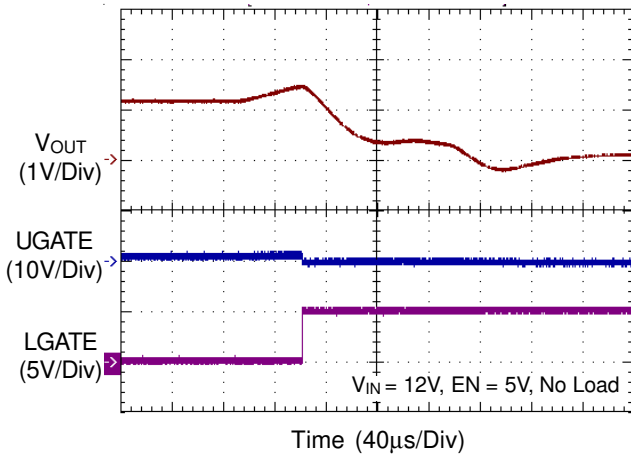

UVP

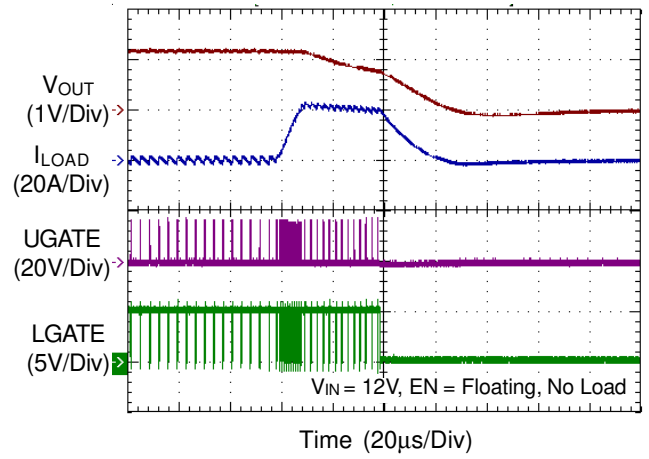

Power On in Short Condition

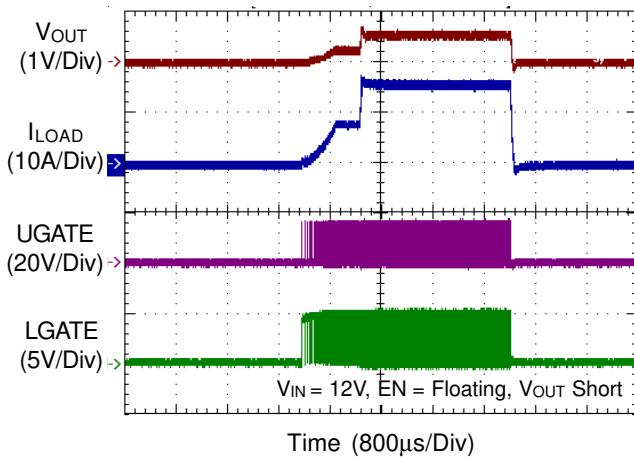

## Application Information

The RT8202/A/B PWM controller provides high efficiency, excellent transient response, and high DC output accuracy needed for stepping down high voltage batteries to generate low voltage CPU core, I/O, and chipset RAM supplies in notebook computers. Richtek Mach Response™ technology is specifically designed for providing 100ns “instant-on” response to load steps while maintaining a relatively constant operating frequency and inductor operating point over a wide range of input voltages. The topology circumvents the poor load transient timing problems of fixed-frequency current mode PWMs while avoiding the problems caused by widely varying switching frequencies in conventional constant-on-time and constant-off-time PWM schemes. The DRV™ mode PWM modulator is specifically designed to have better noise immunity for such a single output application.

### PWM Operation

The Mach Response™ DRV™ mode controller relies on the output filter capacitor's effective series resistance (ESR) to act as a current sense resistor, so the output ripple voltage provides the PWM ramp signal. Refer to the function diagrams of RT8202/A/B, the synchronous high side MOSFET is turned on at the beginning of each cycle. After the internal one-shot timer expires, the MOSFET is turned off. The pulse width of this one shot is determined by the converter's input and output voltages to keep the frequency fairly constant over the input voltage range. Another one-shot sets a minimum off-time (400ns typ.).

### On-Time Control (TON)

The on-time one-shot comparator has two inputs. One input monitors the output voltage, while the other input samples the input voltage and converts it to a current. This input voltage proportional current is used to charge an internal on-time capacitor. The on-time is the time required for the voltage on this capacitor to charge from zero volts to  $V_{OUT}$ , thereby making the on-time of the high side switch directly proportional to output voltage and inversely proportional to input voltage. The implementation results in a nearly constant switching frequency without the need a clock generator.

$$T_{ON} = 3.85p \times R_{TON} \times V_{OUT} / (V_{IN} - 0.5)$$

And then the switching frequency is :

$$\text{Frequency} = V_{OUT} / (V_{IN} \times T_{ON})$$

$R_{TON}$  is a resistor connected from the input supply ( $V_{IN}$ ) to TON pin.

### Mode Selection (EN/DEM) Operation

The EN/DEM pin enables the supply. When EN/DEM is tied to VDD, the controller is enabled and operates in diode-emulation mode. When the EN/DEM pin is floating, the RT8202/A/B will operate in forced-CCM mode.

### Diode-Emulation Mode (EN/DEM = High)

In diode-emulation mode, RT8202/A/B automatically reduces switching frequency at light-load conditions to maintain high efficiency. This reduction of frequency is achieved smoothly and without increasing  $V_{OUT}$  ripple or load regulation. As the output current decreases from heavy-load condition, the inductor current is also reduced, and eventually comes to the point that its valley touches zero current, which is the boundary between continuous conduction and discontinuous conduction modes. By emulation the behavior of diodes, the low-side MOSFET allows only partial of negative current when the inductor freewheeling current reach negative. As the load current is further decreased, it takes longer and longer to discharge the output capacitor to the level than requires the next “ON” cycle. The on-time is kept the same as that in the heavy-load condition. In reverse, when the output current increases from light load to heavy load, the switching frequency increases to the preset value as the inductor current reaches the continuous condition. The transition load point to the light load operation can be calculated as follows (Figure 1) :

$$I_{LOAD} \approx \frac{(V_{IN} - V_{OUT})}{2L} \times T_{ON}$$

where  $T_{ON}$  is On-time.

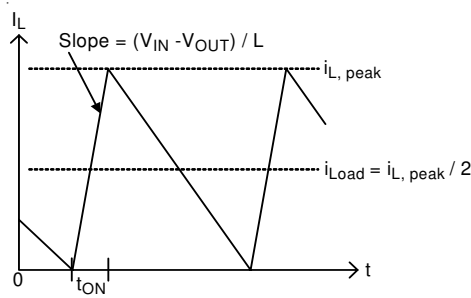

Figure 1. Boundary condition of CCM/DEM

The switching waveforms may appear noisy and asynchronous when light loading causes diode-emulation operation, but this is a normal operating condition that results in high light-load efficiency. Trade-offs in DEM noise vs. light-load efficiency are made by varying the inductor value. Generally, low inductor values produce a broader efficiency vs. load curve, while higher values result in higher full-load efficiency (assuming that the coil resistance remains fixed) and less output voltage ripple. The disadvantages for using higher inductor values include larger physical size and degrades load-transient response (especially at low input voltage levels).

**Forced-CCM Mode (EN/DEM = floating)**

The low noise, forced-CCM mode (EN/DEM = floating) disables the zero-crossing comparator, which controls the low-side switch on-time. This causes the low side gate-drive waveform to become the complement of the high side gate-drive waveform. This in turn causes the inductor current to reverse at light loads as the PWM loop to maintain a duty ratio  $V_{OUT}/V_{IN}$ . The benefit of forced-CCM mode is to keep the switching frequency fairly constant, but it comes at a cost : The no-load battery current can be up to 10mA to 40mA, depending on the external MOSFETs.

**Current Limit Setting (OCP)**

RT8202/A/B has cycle-by-cycle current limiting control. The current limit circuit employs a unique “valley” current sensing algorithm. If the magnitude of the current-sense signal at OC is above the current limit threshold, the PWM is not allowed to initiate a new cycle (Figure 2).

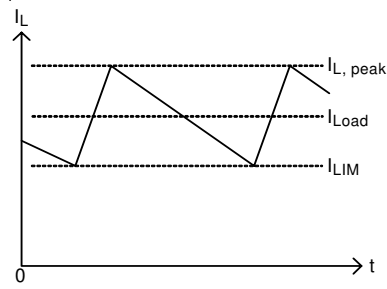

Figure 2. Valley Current-Limit

Current sensing of the RT8202/A/B can be accomplished in two ways. Users can either use a current sense resistor or the on-state of the low side MOSFET ( $R_{DS(ON)}$ ). For resistor sensing, a sense resistor is placed between the source of low-side MOSFET and PGND (Figure 3(a)).  $R_{DS(ON)}$  sensing is more efficient and less expensive (Figure 3(b)). There is a compromise between current-limit accuracy and sense resistor power dissipation.

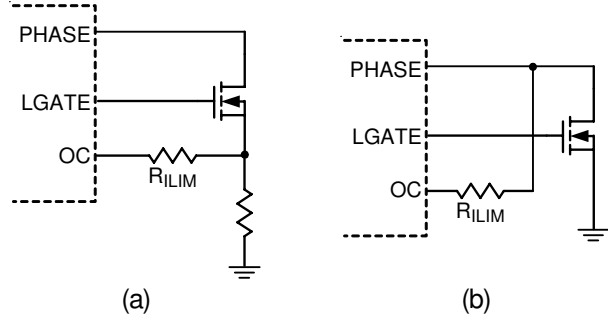

Figure 3. Current-Sense Methods

In both cases, the  $R_{ILIM}$  resistor between the OC pin and PHASE pin sets the over current threshold. This resistor  $R_{ILIM}$  is connected to a  $20\mu A$  current source within the RT8202/A/B which is turned on when the low side MOSFET turns on. When the voltage drop across the sense resistor or low side MOSFET equals the voltage across the  $R_{ILIM}$  resistor, positive current limit will activate. The high side MOSFET will not be turned on until the voltage drop across the sense element (resistor or MOSFET) falls below the voltage across the  $R_{ILIM}$  resistor.

Choose a current limit resistor by following Equation :

$$R_{ILIM} = I_{LIMIT} \times R_{SENSE} / 20\mu A$$

Carefully observe the PC board layout guidelines to ensure that noise and DC errors do not corrupt the current-sense signal seen by OC and PGND. Mount the IC close to the low-side MOSFET and sense resistor with short, direct

traces, making a Kelvin sense connection to the sense resistor.

### MOSFET Gate Driver (UGATE, LGATE)

The high side driver is designed to drive high current, low  $R_{DS(ON)}$  N-MOSFET(s). When configured as a floating driver, 5V bias voltage is delivered from VDDP supply. The average drive current is proportional to the gate charge at  $V_{GS} = 5V$  times switching frequency. The instantaneous drive current is supplied by the flying capacitor between BOOT and PHASE pins.

A dead time to prevent shoot through is internally generated between high side MOSFET off to low side MOSFET on, and low side MOSFET off to high side MOSFET on.

The low side driver is designed to drive high current, low  $R_{DS(ON)}$  N-MOSFET(s). The internal pull-down transistor that drives LGATE low is robust, with a  $0.6\Omega$  typical on-resistance. A 5V bias voltage is delivered from VDDP supply. The instantaneous drive current is supplied by the flying capacitor between VDDP and PGND.

For high current applications, some combinations of high and low side MOSFETs might be encountered that will cause excessive gate-drain coupling, which can lead to efficiency killing, EMI producing shoot through currents. This is often remedied by adding a resistor in series with BOOT, which increases the turn-on time of the high side MOSFET without degrading the turn-off time (Figure 4).

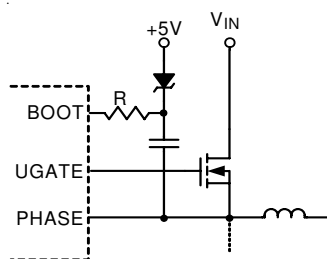

Figure 4. Reducing the UGATE Rise Time

### Power Good Output (PGOOD)

The power good output is an open-drain output and requires a pull up resistor. When the output voltage is 15% above or 10% below its set voltage, PGOOD gets pulled low. It is held low until the output voltage returns to within these tolerances once more. In soft start, PGOOD is actively

held low and is allowed to transition high until soft start is over and the output reaches 93% of its set voltage. There is a  $2.5\mu s$  delay built into PGOOD circuitry to prevent false transition.

### POR, UVLO and Soft-Start

Power on reset (POR) occurs when VDD rises above to approximately 4.3V, the RT8202/A/B will reset the fault latch and preparing the PWM for operation. Below  $4.1V_{(MIN)}$ , the VDD under voltage-lockout (UVLO) circuitry inhibits switching by keeping UGATE and LGATE low.

A built-in soft-start is used to prevent surge current from power supply input after EN/DEM is enabled. It clamps the ramping of internal reference voltage which is compared with FB signal. The typical soft-start duration is 1.35ms.

Furthermore, the maximum allowed current limit is segment in 2 steps during 1.35ms period.

### Output Over Voltage Protection (OVP)

The output voltage can be continuously monitored for over voltage protection. When the output voltage exceeds 15% of the its set voltage threshold, over voltage protection is triggered and the low side MOSFET is latched on. This activates the low side MOSFET to discharge the output capacitor.

RT8202/A/B is latched once OVP is triggered and can only be released by VDD or EN/DEM power on reset. There is  $20\mu s$  delay built into the over voltage protection circuit to prevent false transitions.

### Output Under Voltage Protection (UVP)

The output voltage can be continuously monitored for under voltage protection. When the output voltage is less than 70% of its set voltage threshold, under voltage protection is triggered and then both UGATE and LGATE gate drivers are forced low. In order to remove the residual charge on the output capacitor during the under voltage period, if PHASE is greater than 1V, the LGATE is forced high until PHASE is lower than 1V. There is  $2.5\mu s$  delay built into the under voltage protection circuit to prevent false transitions. During soft-start, the UVP will be blanked around 3.1ms.

**Output Voltage Setting (FB)**

The output voltage can be adjusted from 0.75V to 3.3V by setting the feedback resistor R1 and R2 (Figure 5). Choose R2 to be approximately 10kΩ, and solve for R1 using the equation:

$$V_{OUT} = V_{FB} \times \left[ 1 + \left( \frac{R1}{R2} \right) \right]$$

where  $V_{FB}$  is 0.75V.

Note that in order for the device to regulate in a controlled manner, the ripple content at the feedback pin,  $V_{FB}$ , should be approximately 15mV at minimum  $V_{BAT}$ , and worst case no smaller than 10mV. If  $V_{ripple}$  at minimum  $V_{BAT}$  is less than 15mV, the above component values should be revisited in order to improve this. Quite often a small capacitor, C1, is required in parallel with the top feedback resistor, R1, in order to ensure that  $V_{FB}$  is large enough. The value of C1 can be calculated as follows, where R2 is the bottom feedback resistor.

Firstly calculating the value of Z1 required :

$$Z1 = \frac{R2}{0.015} \times (V_{ripple\_VBAT(MIN)} - 0.015) \Omega$$

Secondly calculating the value of C1 required to achieve this :

$$C1 = \frac{\left( \frac{1}{Z1} - \frac{1}{R1} \right)}{2 \times \pi \times f_{SW\_VBAT(MIN)}} F$$

Finally using the equation as follows to verify the value of  $V_{FB}$  :

$$V_{FB\_VBAT(MIN)} = V_{ripple\_VBAT(MIN)} \times \left[ \frac{R2}{R2 + \frac{1}{\frac{1}{R1} + 2 \times \pi \times f_{SW\_VBAT(MIN)} \times C1}} \right] V$$

where  $V_{ripple\_VBAT(MIN)}$  is the output ripple voltage in minimum  $V_{BAT}$ ;

$f_{sw\_VBAT(MIN)}$  is the switching frequency in minimum  $V_{BAT}$ ;

$V_{FB\_VBAT(MIN)}$  is the ripple voltage into FB pin in minimum  $V_{BAT}$ .

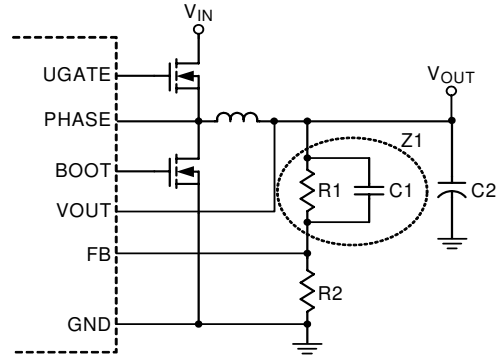

Figure 5. Setting The Output Voltage

For application that output voltage is higher than 3.3V, user can also use a voltage divider to keep  $V_{OUT}$  pin voltage within 0.75V to 2.8V as shown in Figure 6. For this case,  $T_{ON}$  can be determined as below :

$$\text{If } R_{TON} < 2M\Omega \text{ then } T_{ON} = 3.85p \times \frac{R_{TON} \times V_{OUT\_FB}}{V_{IN} - 0.5}$$

$$\text{If } R_{TON} \geq 2M\Omega \text{ then } T_{ON} = 3.55p \times \frac{R_{TON} \times V_{OUT\_FB}}{V_{IN} - 0.4}$$

Where  $R_{TON}$  is  $T_{ON}$  set resistor and the  $V_{OUT\_FB}$  is the output signal of resistor divider. Since the switching frequency is

$$f_s = \frac{V_{OUT}}{V_{IN} \times T_{ON}}$$

For a given switching frequency, we can obtain the  $R_{TON}$  as below

If  $R_{TON} < 2M\Omega$  then

$$R_{TON} = \frac{V_{OUT} - 0.5}{V_{IN}} \times \frac{V_{OUT}}{V_{OUT\_FB}} \times \frac{1}{f_s \times 3.85p}$$

If  $R_{TON} \geq 2M\Omega$  then

$$R_{TON} = \frac{V_{OUT} - 0.4}{V_{IN}} \times \frac{V_{OUT}}{V_{OUT\_FB}} \times \frac{1}{f_s \times 3.55p}$$

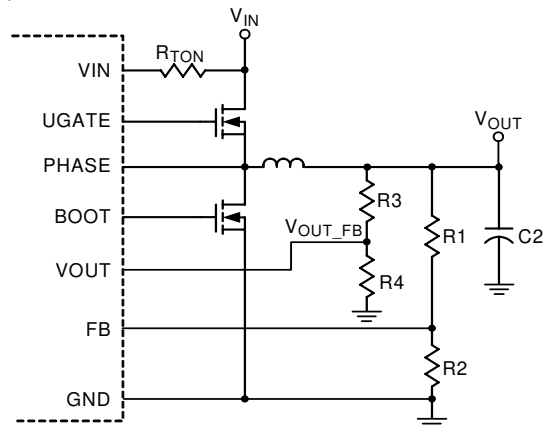

Figure 6. Output Voltage Setting for  $V_{OUT} > 3.3V$  Application

## Output Inductor Selection

The switching frequency (on-time) and operating point (% ripple or  $L_{IR}$ ) determine the inductor value as follows :

$$L = \frac{T_{ON} \times (V_{IN} - V_{OUT})}{L_{IR} \times I_{LOAD(MAX)}}$$

Find a low pass inductor having the lowest possible DC resistance that fits in the allowed dimensions. Ferrite cores are often the best choice, although powdered iron is inexpensive and can work well at 200kHz. The core must be large enough and not to saturate at the peak inductor current ( $I_{PEAK}$ ) :

$$I_{PEAK} = I_{LOAD(MAX)} + [(L_{IR} / 2) \times I_{LOAD(MAX)}]$$

## Output Capacitor Selection

The output filter capacitor must have ESR low enough to meet output ripple and load transient requirement, yet have high enough ESR to satisfy stability requirements. Also, the capacitance value must be high enough to absorb the inductor energy going from a full load to no load condition without tripping the OVP circuit.

For CPU core voltage converters and other applications where the output is subject to violent load transient, the output capacitor's size depends on how much ESR is needed to prevent the output from dipping too low under a load transient. Ignoring the sag due to finite capacitance :

$$ESR \leq \frac{V_{P-P}}{I_{LOAD(MAX)}}$$

In non-CPU applications, the output capacitor's size depends on how much ESR is needed to maintain at an acceptable level of output voltage ripple :

$$ESR \leq \frac{V_{P-P}}{L_{IR} \times I_{LOAD(MAX)}}$$

Organic semiconductor capacitor(s) or specially polymer capacitor(s) are recommended.

## Output Capacitor Stability

Stability is determined by the value of the ESR zero relative to the switching frequency. The point of instability is given by the following equation :

$$f_{ESR} = \frac{1}{2 \times \pi \times ESR \times C_{OUT}} \leq \frac{f_{SW}}{4}$$

Do not put high value ceramic capacitors directly across the outputs without taking precautions to ensure stability. Large ceramic capacitors can have a high ESR zero frequency and cause erratic and unstable operation. However, it is easy to add sufficient series resistance by placing the capacitors a couple of inches downstream from the inductor and connecting  $V_{OUT}$  or FB divider close to the inductor.

There are two related but distinct ways including double pulsing and feedback loop instability to identify the unstable operation.

Double-pulsing occurs due to noise on the output or because the ESR is too low that there is not enough voltage ramp in the output voltage signal. The “fools” the error comparator into triggering a new cycle immediately after 400ns minimum off-time period has expired. Double-pulsing is more annoying than harmful, resulting in nothing worse than increased output ripple. However, it may indicate the possible presence of loop instability, which is caused by insufficient ESR.

Loop instability can result in oscillation at the output after line or load perturbations that can trip the over voltage protection latch or cause the output voltage to fall below the tolerance limit.

The easiest method for stability checking is to apply a very zero-to-max load transient and carefully observe the output-voltage-ripple envelope for overshoot and ringing. It helps to simultaneously monitor the inductor current with AC probe. Do not allow more than one ringing cycle after the initial step-response under- or over-shoot.

## Thermal Considerations

For continuous operation, do not exceed absolute maximum operation junction temperature.

The maximum power dissipation depends on the thermal resistance of IC package, PCB layout, the rate of surroundings airflow and temperature difference between junction to ambient. The maximum power dissipation can be calculated by following formula :

$$P_{D(MAX)} = (T_{J(MAX)} - T_A) / \theta_{JA}$$

Where  $T_{J(MAX)}$  is the maximum operation junction temperature 125°C,  $T_A$  is the ambient temperature and the  $\theta_{JA}$  is the junction to ambient thermal resistance.

For recommended operating conditions specification of RT8202/A/B, where  $T_{J(MAX)}$  is the maximum junction temperature of the die (125°C) and  $T_A$  is the maximum ambient temperature. The junction to ambient thermal resistance  $\theta_{JA}$  is layout dependent. For WQFN-16L 3x3 packages, the thermal resistance  $\theta_{JA}$  is 68°C/W on the standard JEDEC 51-7 four layers thermal test board. For WQFN-14L 3.5x3.5 package, the thermal resistance  $\theta_{JA}$  is 60°C/W on the standard JEDEC 51-7 four layers thermal test board. The maximum power dissipation at  $T_A = 25^\circ\text{C}$  can be calculated by following formula :

$$P_{D(MAX)} = (125^\circ\text{C} - 2^\circ\text{C}) / (68^\circ\text{C/W}) = 1.471\text{W for WQFN-16L 3x3 packages}$$

$$P_{D(MAX)} = (125^\circ\text{C} - 25^\circ\text{C}) / (54^\circ\text{C/W}) = 1.852\text{W for WQFN-16L 4x4 packages}$$

$$P_{D(MAX)} = (125^\circ\text{C} - 25^\circ\text{C}) / (60^\circ\text{C/W}) = 1.667\text{W for WQFN-14L 3.5x3.5 packages}$$

The maximum power dissipation depends on operating ambient temperature for fixed  $T_{J(MAX)}$  and thermal resistance  $\theta_{JA}$ . For RT8202/A/B packages, the Figure 7 of derating curves allows the designer to see the effect of rising ambient temperature on the maximum power allowed.

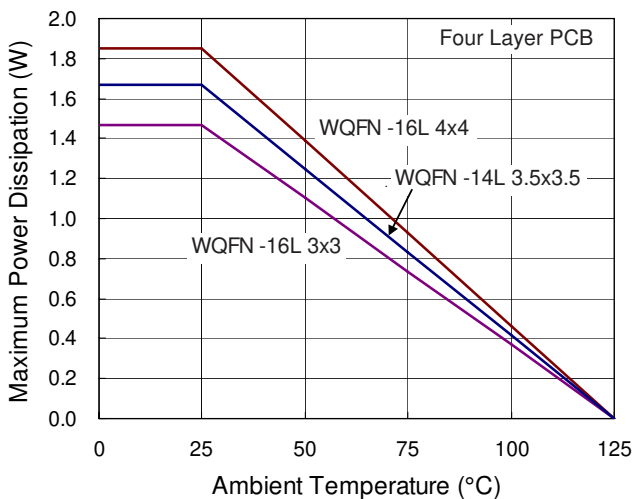

Figure 7. Derating Curves for RT8202/A/B Packages

**Layout Considerations**

Layout is very important in high frequency switching converter design. If designed improperly, the PCB could radiate excessive noise and contribute to the converter instability. Certain points must be considered before starting a layout for RT8202/A/B.

- ▶ Connect RC low pass filter from VDDP to VDD, 1uF and 10Ω are recommended. Place the filter capacitor close to the IC.
- ▶ Keep current limit setting network as close as possible to the IC. Routing of the network should avoid coupling to high voltage switching node.
- ▶ Connections from the drivers to the respective gate of the high side or the low side MOSFET should be as short as possible to reduce stray inductance.
- ▶ All sensitive analog traces and components such as VOUT, FB, GND, EN/DEM, PGOOD, OC, VDD, and TON should be placed away from high voltage switching nodes such as PHASE, LGATE, UGATE, or BOOT nodes to avoid coupling. Use internal layer(s) as ground plane(s) and shield the feedback trace from power traces and components.
- ▶ Current sense connections must always be made using Kelvin connections to ensure an accurate signal, with the current limit resistor located at the device.
- ▶ Power sections should connect directly to ground plane(s) using multiple vias as required for current handling (including the chip power ground connections). Power components should be placed to minimize loops and reduce losses.

Outline Dimension

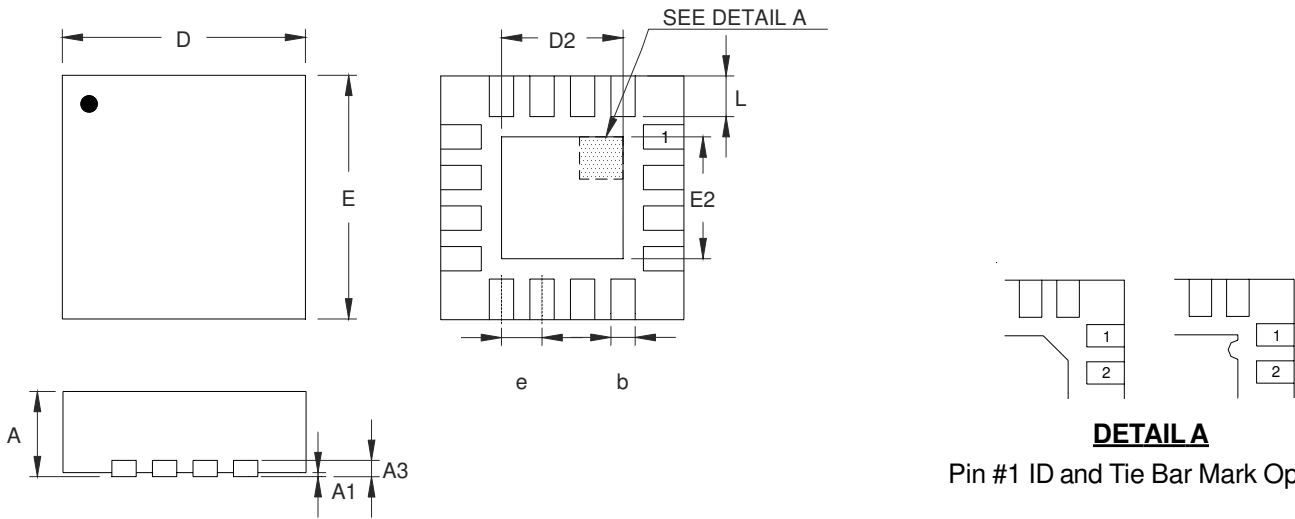

**DETAIL A**  
Pin #1 ID and Tie Bar Mark Options

Note : The configuration of the Pin #1 identifier is optional, but must be located within the zone indicated.

Symbol	Dimensions In Millimeters		Dimensions In Inches	
	Min	Max	Min	Max
A	0.700	0.800	0.028	0.031
A1	0.000	0.050	0.000	0.002
A3	0.175	0.250	0.007	0.010
b	0.180	0.300	0.007	0.012
D	2.950	3.050	0.116	0.120
D2	1.300	1.750	0.051	0.069
E	2.950	3.050	0.116	0.120
E2	1.300	1.750	0.051	0.069
e	0.500		0.020	
L	0.350	0.450	0.014	0.018

W-Type 16L QFN 3x3 Package



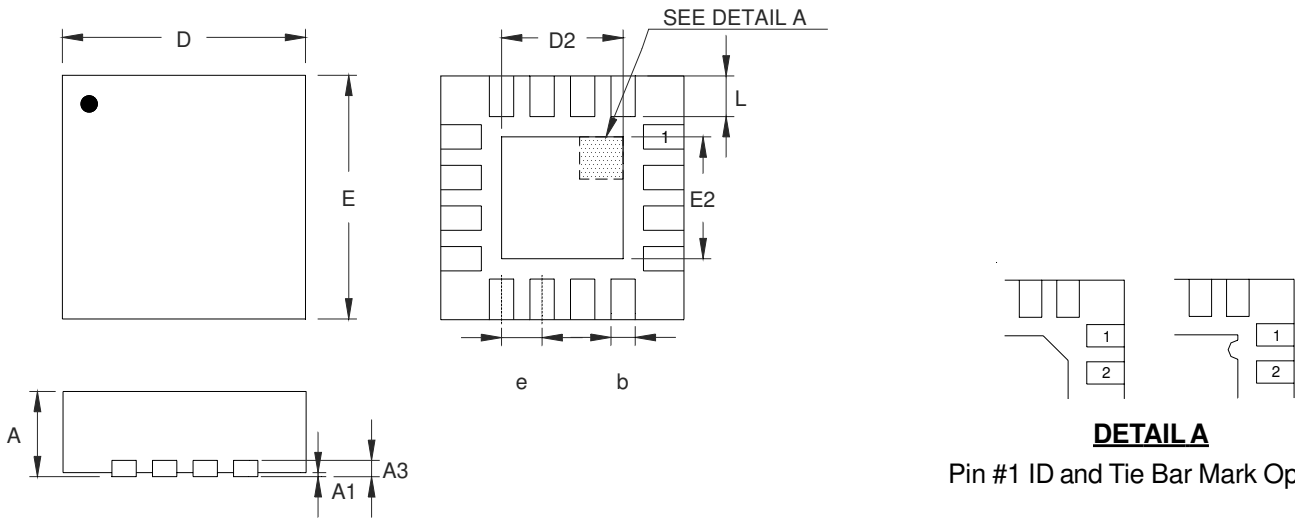

Note : The configuration of the Pin #1 identifier is optional, but must be located within the zone indicated.

Symbol	Dimensions In Millimeters		Dimensions In Inches	
	Min	Max	Min	Max
A	0.700	0.800	0.028	0.031
A1	0.000	0.050	0.000	0.002
A3	0.175	0.250	0.007	0.010
b	0.250	0.380	0.010	0.015
D	3.950	4.050	0.156	0.159
D2	2.000	2.450	0.079	0.096
E	3.950	4.050	0.156	0.159
E2	2.000	2.450	0.079	0.096
e	0.650		0.026	
L	0.500	0.600	0.020	0.024

**W-Type 16L QFN 4x4 Package**

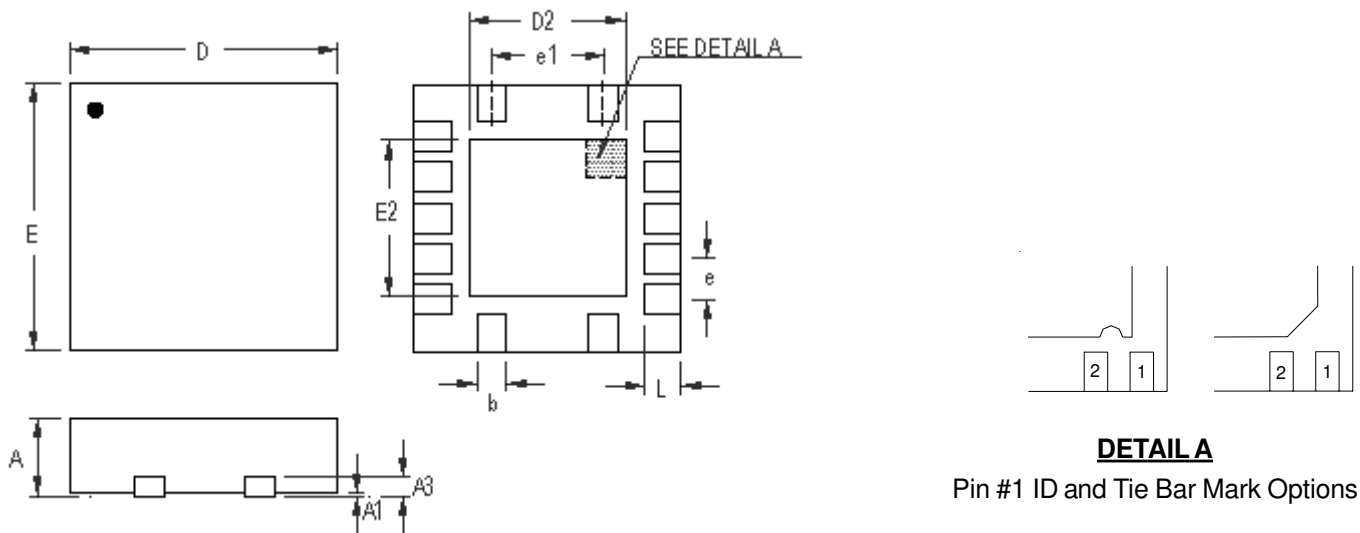

Pin #1 ID and Tie Bar Mark Options

note : the configuration of the Pin #1 identifier is optional, but must be located within the zone indicated.

Symbol	Dimensions In Millimeters		Dimensions In Inches	
	Min	Max	Min	Max
A	0.700	0.800	0.028	0.031
A1	0.000	0.050	0.000	0.002
A3	0.175	0.250	0.007	0.010
b	0.180	0.300	0.007	0.012
D	3.400	3.600	0.134	0.142
D2	1.950	2.150	0.077	0.085
E	3.400	3.600	0.134	0.142
E2	1.950	2.150	0.077	0.085
e	0.500		0.020	
e1	1.500		0.060	
L	0.300	0.500	0.012	0.020

W-Type 14L QFN 3.5x3.5 Package

**Richtek Technology Corporation**

Headquarter  
 5F, No. 20, Taiyuen Street, Chupei City  
 Hsinchu, Taiwan, R.O.C.  
 Tel: (8863)5526789 Fax: (8863)5526611

**Richtek Technology Corporation**

Taipei Office (Marketing)  
 8F, No. 137, Lane 235, Paochiao Road, Hsintien City  
 Taipei County, Taiwan, R.O.C.  
 Tel: (8862)89191466 Fax: (8862)89191465  
 Email: marketing@richtek.com

Information that is provided by Richtek Technology Corporation is believed to be accurate and reliable. Richtek reserves the right to make any change in circuit design, specification or other related things if necessary without notice at any time. No third party intellectual property infringement of the applications should be guaranteed by users when integrating Richtek products into any application. No legal responsibility for any said applications is assumed by Richtek.