

- NOTES:
1. MATERIAL:
STAINLESS STEEL 304 THICKNESS 0.5MM
 2. FINISH:
NON-PLATING
 3. COMPLIANT TO RoHS DIRECTIVE 200/95/EC AND ELV 2000/53/EC

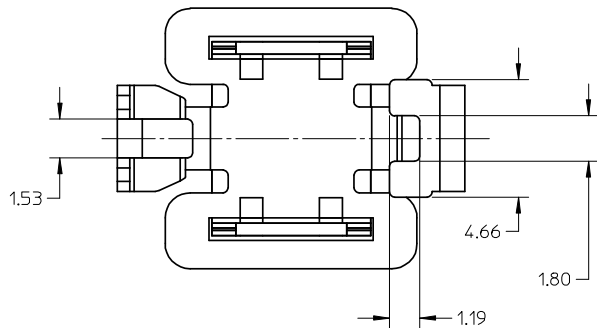
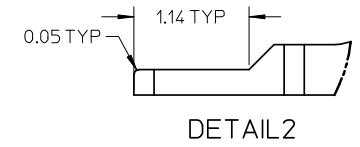
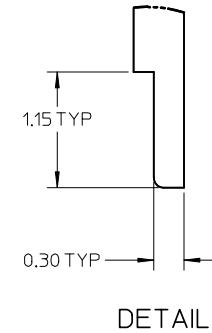
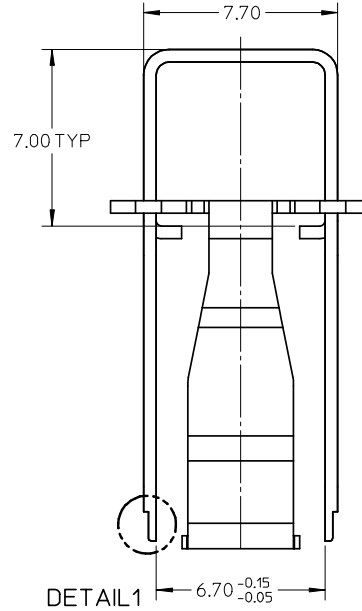
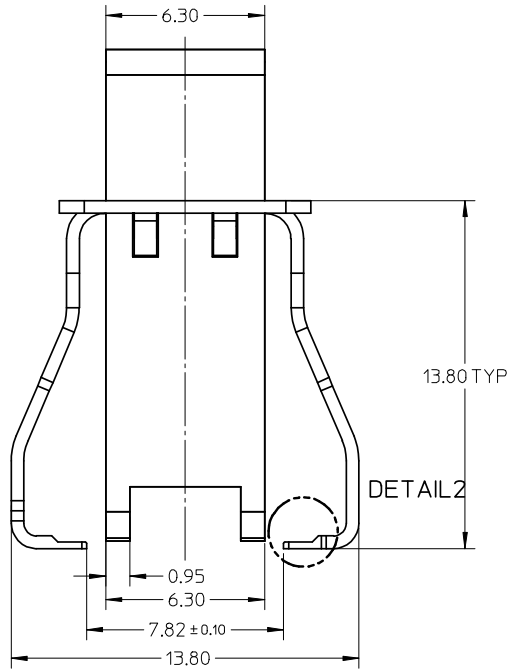
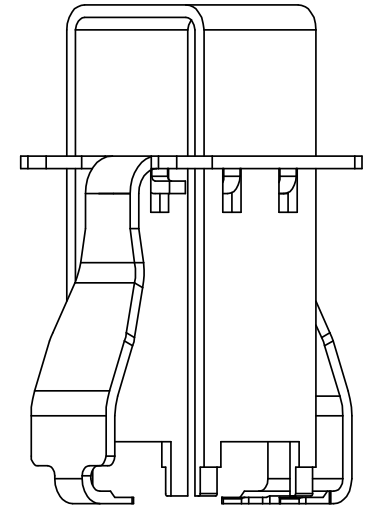

NEW RELEASE EC NO: SH2008-0421 DRWN: MSH CHKD: YLZHU APPR: HWWANG 2008/02/22 2008/03/20	QUALITY SYMBOLS $\nabla=0$ $\square=0$	GENERAL TOLERANCES (UNLESS SPECIFIED)		DIMENSION STYLE MM ONLY	SCALE 8:1	DESIGN UNITS METRIC	THIRD ANGLE PROJECTION															
		<table border="1"> <thead> <tr> <th></th> <th>mm</th> <th>INCH</th> </tr> </thead> <tbody> <tr> <td>4 PLACES</td> <td>± ---</td> <td>± ---</td> </tr> <tr> <td>3 PLACES</td> <td>± ---</td> <td>± ---</td> </tr> <tr> <td>2 PLACES</td> <td>± 0.15</td> <td>± ---</td> </tr> <tr> <td>1 PLACE</td> <td>± ---</td> <td>± ---</td> </tr> </tbody> </table>		mm	INCH	4 PLACES	± ---	± ---	3 PLACES	± ---	± ---	2 PLACES	± 0.15	± ---	1 PLACE	± ---	± ---	DRAWN BY MSH1	DATE 2007/08/27	TITLE EXTRACTOR FOR CAMERA SOCKET 6.5X6.5 TYPE		
		mm	INCH																			
	4 PLACES	± ---	± ---																			
3 PLACES	± ---	± ---																				
2 PLACES	± 0.15	± ---																				
1 PLACE	± ---	± ---																				
		CHECKED BY YLZHU	DATE 2007/10/31	MOLEX INCORPORATED																		
		APPROVED BY HWWANG	DATE 2007/10/31	MATERIAL NO. 475860008	DOCUMENT NO. SD-47586-008	SHEET NO. 1 OF 1																
		DRAFT WHERE APPLICABLE MUST REMAIN WITHIN DIMENSIONS		SIZE A3	THIS DRAWING CONTAINS INFORMATION THAT IS PROPRIETARY TO MOLEX INCORPORATED AND SHOULD NOT BE USED WITHOUT WRITTEN PERMISSION																	