

STRAIGHT FEMALE PLUG CRIMP TYPE

R222.M80.400

CABLE 2.6/50S

Series : SMP-MAX

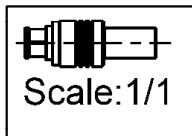
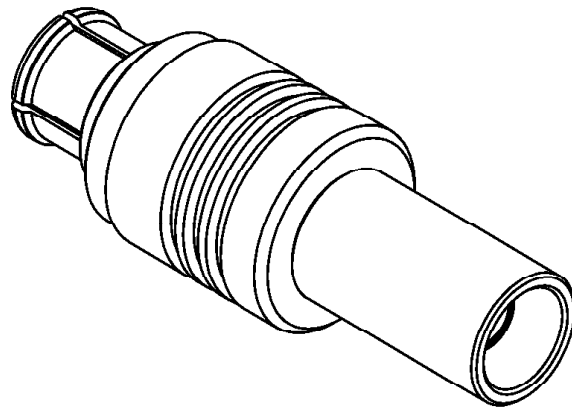
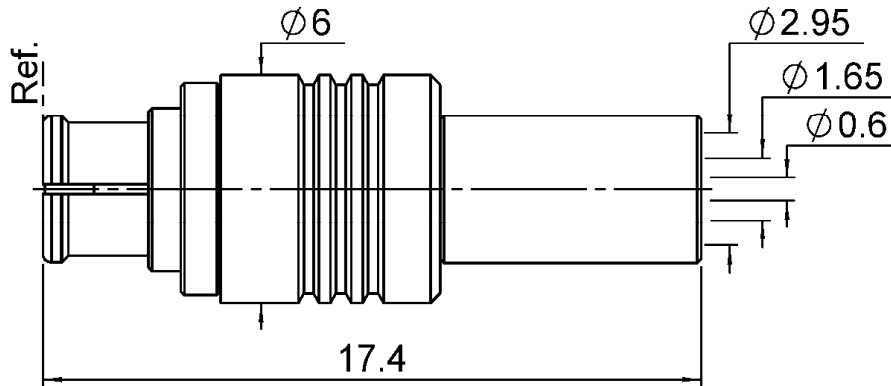

All dimensions are in mm.

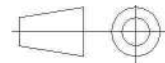

COMPONENTS	MATERIALS	PLATING (µm)
BODY	BRASS	NPGR
CENTER CONTACT	BERYLLIUM COPPER	NPGR
OUTER CONTACT	BERYLLIUM COPPER	NPGR
INSULATOR	PTFE	
GASKET		
OTHERS PARTS	BRASS	GOLD OVER NICKEL
-	-	-
-	-	-

Issue : 1104 A

In the effort to improve our products, we reserve the right to make changes judged to be necessary.



STRAIGHT FEMALE PLUG CRIMP TYPE

R222.M80.400

CABLE 2.6/50S

Series : **SMP-MAX**

PACKAGING

Standard	Unit	Other
100	'W' option	Contact us

SPECIFICATION

ELECTRICAL CHARACTERISTICS

Impedance		50 Ω
Frequency		0-6 GHz
VSWR	1.05 +	0,0300 x F(GHz) Maxi
Insertion loss		0.05 √F(GHz) dB Maxi
RF leakage	- (NA - F(GHz)) dB Maxi
Voltage rating		335 Veff Maxi
Dielectric withstanding voltage		750 Veff mini
Insulation resistance		5000 MΩ mini

CABLE ASSEMBLY

Stripping	a	b	c	d	e	f
mm	2,00	5,00	9,20	0,00	7,20	0,00

Assembly instruction : **Crimp 02**

Recommended cable(s)

RG 174
RG 316
KX 22A
ECO 316

Characteristics indicated on this data sheet are those that can be achieved with the highest performance cable. Intrinsic limitations of the cable may diminish the performance of the assembly

Cable retention

- pull off **53** N mini
- torque **NA** N.cm

MECHANICAL CHARACTERISTICS

Center contact retention		
Axial force – Mating end	NA	N mini
Axial force – Opposite end	NA	N mini
Torque	NA	N.cm mini

TOOLING

Part Number	Description	Hexagon
.	.	.
R282.211.000	CRIMPING TOOL	
R282.235.003	CRIMPING DIES M22520/5-03	3.25
R282.271.000	CRIMPING TOOL	3.25- SQUARE 0.72

Recommended torque		
Mating	NA	N.cm
Panel nut	NA	N.cm
Clamp nut	NA	N.cm
A/F clamp nut	0,0000	mm

Mating life	100	Cycles mini
Weight	1,7070	g

ENVIRONMENTAL

Operating temperature	-55/+165	° C
Hermetic seal	NA	Atm.cm3/s
Panel leakage	NA	

OTHER CHARACTERISTICS

Issue : **1104 A**

In the effort to improve our products, we reserve the right to make changes judged to be necessary.

