

50-4000 MHz Cascadable InGaP HBT Gain Block

Device Features

- This can be operated at V_c of 3.3V and 4.0V
- Internally matched to 50 ohms
- 30.0 dBm Output IP3 at -3 dBm/tone at 1900MHz
- 14.6 dB Gain at 1900MHz
- 2.1dB Typical N.F at 1900MHz
- Highly Reliable InGaP/GaAs HBT Technology
- RoHS2-compliant SOT-363 SMT package

Product Description

BeRex's BGS4 is a high performance InGaP/GaAs HBT MMIC amplifier, internally matched to 50 Ohms and requires no external matching components. The BGS4 is designed for high linearity gain block applications. It is packaged in a RoHS2-compliant with SOT-363 surface mount package.

Applications

- Base station Infrastructure/RFID
- Commercial/Industrial/Military wireless system

Applications Circuit

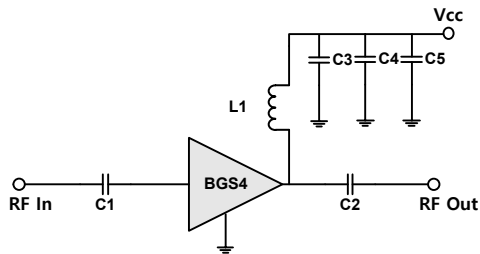

BOM	50~600MHz	600~1700MHz	1700~2500MHz	2500~4000MHz
C1	820pF	100pF	4.7pF	8.2pF
C2	820pF	100pF	20pF	15pF
C3	100pF	100pF	100pF	100pF
C4	1nF	1nF	1nF	1nF
C5	1uF	1uF	1uF	1uF
L1	820nH	82nH	18nH	12nH

Part Marking (XX:Wafer number)



Pin Description	
RF IN	3
RF OUT	6
GND	1,2,4,5

Electrical Specifications

Device performance _ measured on a BeRex evaluation board at 25°C, $V_d=3.3V$, 50 Ω system.

Parameter	Conditions	Min	Typ	Max	Unit
Operational Frequency Range		50		4000	MHz
Test Frequency			1900		MHz
Gain		13.1	14.6		dB
Input Return Loss			-13.0		dB
Output Return Loss			-16.0		dB
Output IP3	0 dBm / tone , $\Delta f=1$ MHz	27.0	30.0		dBm
Output P1dB		17.8	18.8		dBm
Noise Figure			2.1		dB

Device performance _ measured on a BeRex evaluation board at 25°C, $V_d=4V$, 50 Ω system.

Parameter	Conditions	Min	Typ	Max	Unit
Operational Frequency Range		50		4000	MHz
Test Frequency			1900		MHz
Gain		14.0	15.5		dB
Input Return Loss			-14.0		dB
Output Return Loss			-16.0		dB
Output IP3	0 dBm / tone , $\Delta f=1$ MHz	28.0	31.0		dBm
Output P1dB		19.8	20.8		dBm
Noise Figure			3.7		dB

Recommended Operating Conditions

Parameter	Min	Typ	Max	Unit
Bandwidth	50		4000	MHz
I_c @ ($V_c = 3.3V$)	21	26	31	mA
I_c @ ($V_c = 4.0V$)	56	70	84	mA
V_c	3.15	3.3	4	V
dG/dT		-0.0026		dB/°C
R_{TH}		62		°C/W
Operating Case Temperature	-40		+105	°C

Electrical specifications are measured at specified test conditions.

Specifications are not guaranteed over all recommended operating conditions.

Absolute Maximum Ratings

Parameter	Rating	Unit
Storage Temperature	-55 to +155	°C
Junction Temperature	+155	°C
Supply Voltage	+5	V
Supply Current	110	mA
Input RF Power	24	dBm

Operation of this device above any of these parameters may result in permanent damage.

Typical Performance ($V_c = 3.3V$, $I_c = 26mA$, $T = 25^\circ C$)

Freq	MHz	70	500	900	1900	2140	2650	3500
S21	dB	24.7	22.0	19.7	14.6	13.6	12.0	10.5
S11	dB	-19.6	-18.1	-12.0	-13.0	-12.0	-10.5	-10.5
S22	dB	-14.0	-14.2	-18.7	-16.0	-16.0	-19.5	-16.0
P1	dBm	20.4	20.3	19.9	18.8	19.0	19.0	18.9
OIP3	dBm	31.0	28.0	28.0	30.0	29.5	30.0	30.0
NF	dB	2.2	2.6	2.1	2.1	2.2	2.3	2.6

Typical Performance ($V_c = 4.0V$, $I_c = 70mA$, $T = 25^\circ C$)

Freq	MHz	70	500	900	1900	2140	2650	3500
S21	dB	25.6	23.2	20.5	15.5	14.6	13.0	11.5
S11	dB	-16.6	-15.1	-12.0	-14.0	-12.0	-11.0	-11.0
S22	dB	-19.0	-17.6	-19.0	-16.0	-16.0	-20.0	-15.0
P1	dBm	22.5	21.7	21.6	20.8	20.9	21.3	22.0
OIP3	dBm	35.5	32.0	31.0	31.0	30.9	30.7	30.8
NF	dB	3.5	3.7	3.3	3.7	3.8	4.0	4.2

V-I Characteristics

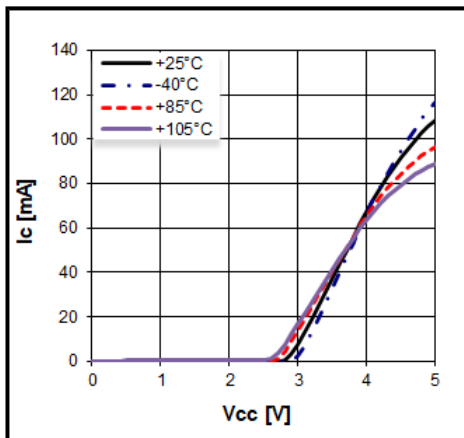

BeRex SOT363 Evaluation Board

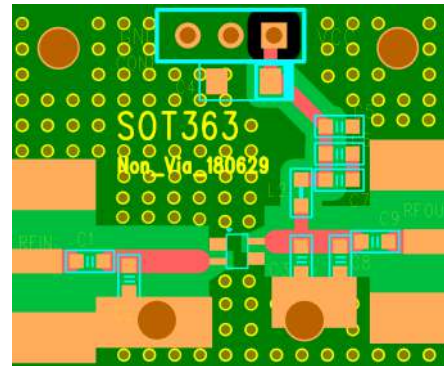

*Dielectric constant _ 4.2 *RF pattern width 52mil *31mil thick FR4

*Without vias under device degrade device performance.

Typical Device Data

S-parameters (Vc=3.3V, Ic=26mA, T=25°C)

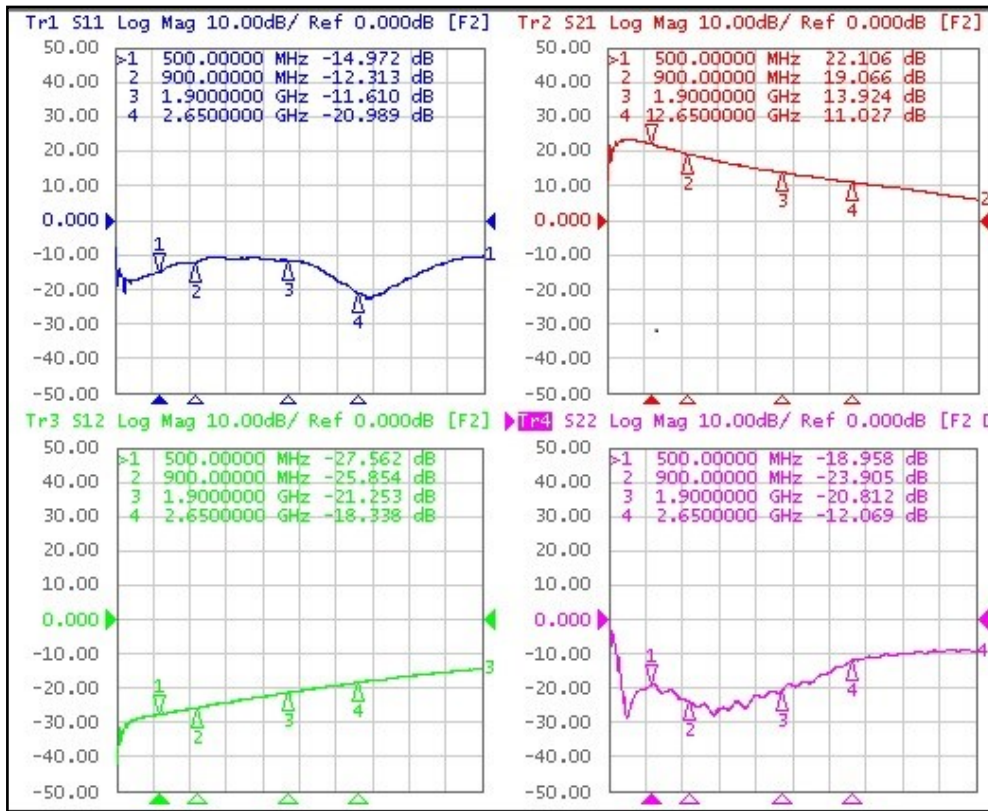

S-Parameter

(Vdevice = 3.3V, Icc = 26mA, T = 25 °C, calibrated to device leads)

Freq [MHz]	S11	S11	S21	S21	S12	S12	S22	S22
	Mag	Ang	Mag	Ang	Mag	Ang	Mag	Ang
70.00	0.12	-173.85	12.21	-135.04	0.03	55.80	0.44	-56.12
500.00	0.18	-166.43	12.71	154.64	0.04	46.69	0.11	49.37
900.00	0.24	170.60	9.00	136.41	0.05	62.38	0.06	91.61
1000.00	0.28	168.22	8.46	134.54	0.05	66.84	0.05	89.54
1500.00	0.29	149.21	6.08	126.99	0.07	80.49	0.05	109.83
2000.00	0.25	135.11	4.70	123.57	0.09	92.29	0.11	155.14
2500.00	0.12	156.50	3.76	121.49	0.11	99.74	0.20	150.62
3000.00	0.11	-117.39	3.09	117.36	0.14	103.77	0.31	-171.12
3500.00	0.23	-114.58	2.50	111.71	0.17	103.71	0.34	-153.16
4000.00	0.30	-131.64	1.98	102.77	0.19	101.11	0.33	-128.69

Typical Performance
 ($V_c = 3.3V, I_c = 26mA, T = 25^\circ C$)

Pin-Pout-Gain

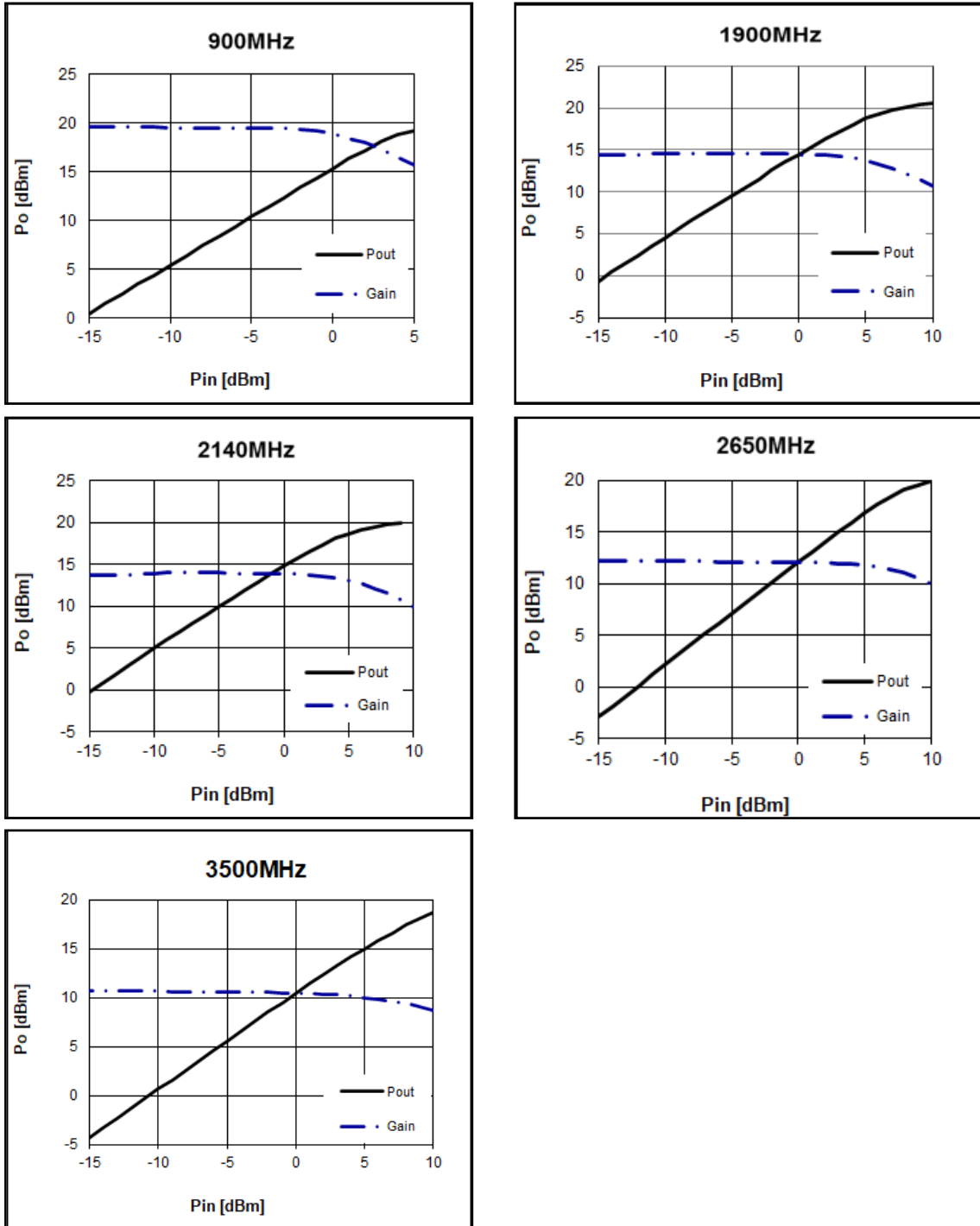

Typical Performance
 ($V_c = 3.3V, I_c = 26mA, T = 25^\circ C$)

OIP3

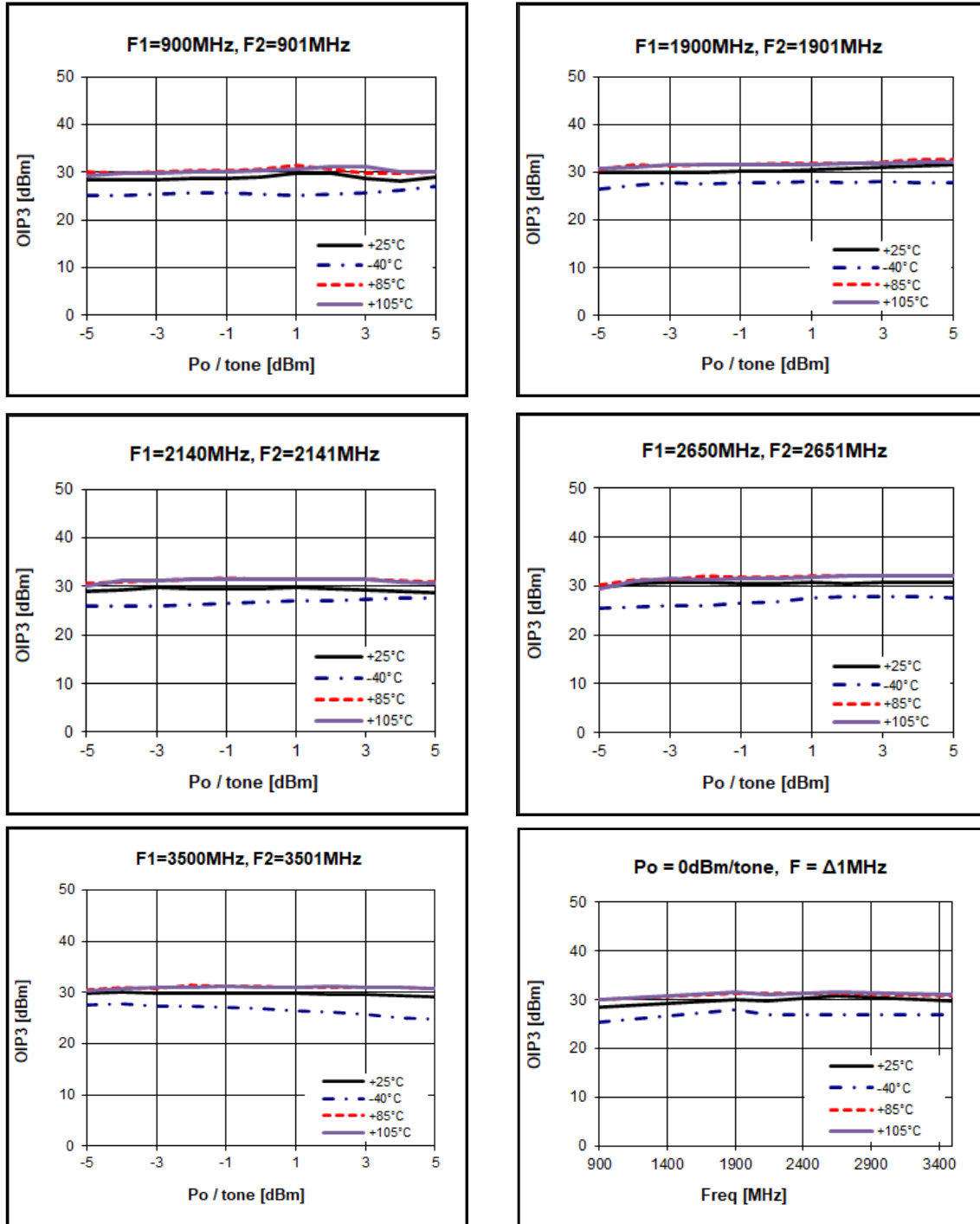

Typical Performance ($V_c = 3.3V, I_c = 26mA, T = 25^\circ C$)

ACP

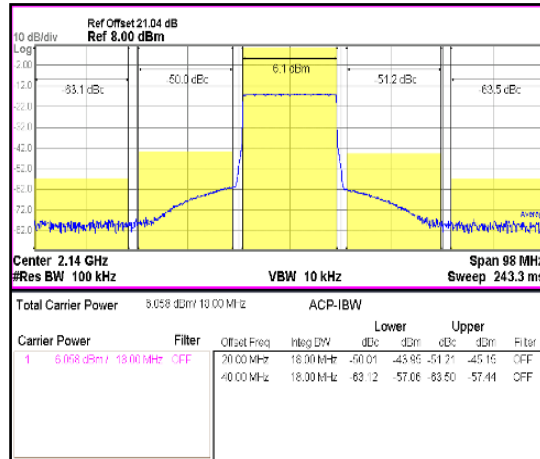
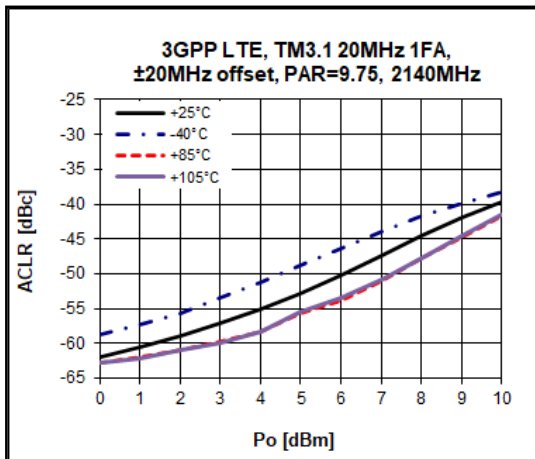
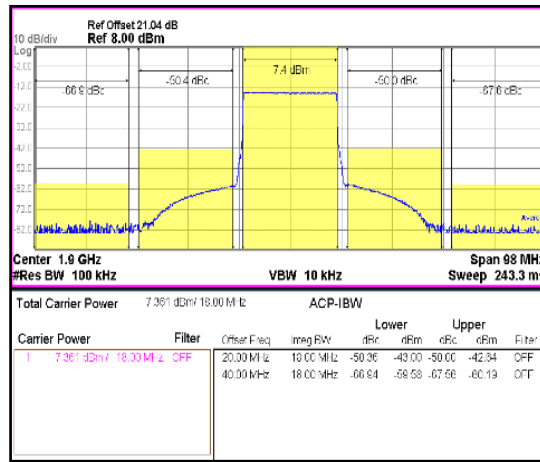
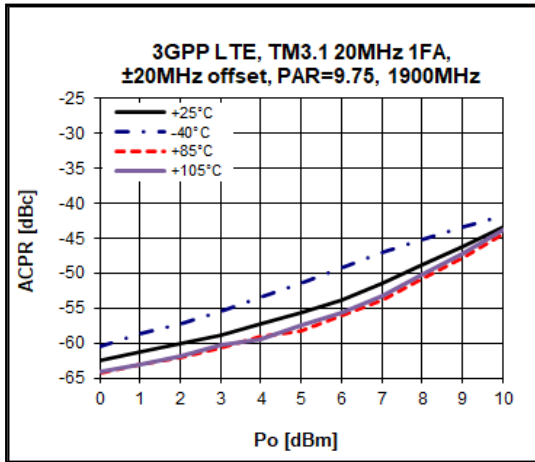
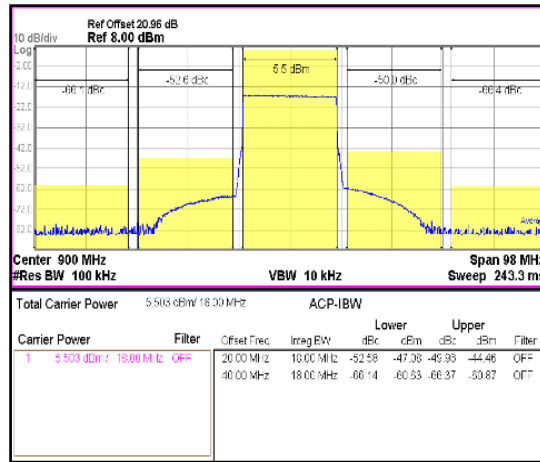
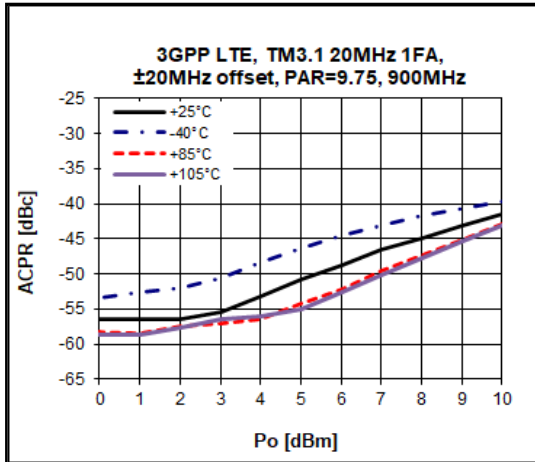

Typical Performance ($V_c = 3.3V, I_c = 26mA, T = 25^\circ C$)

ACP

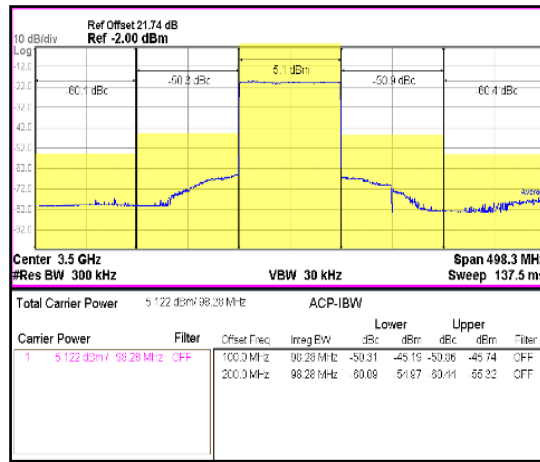
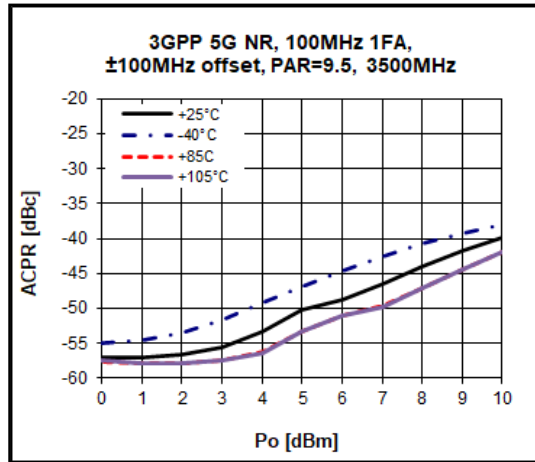
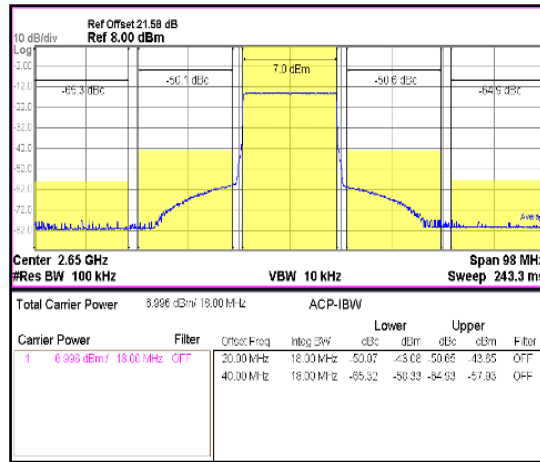
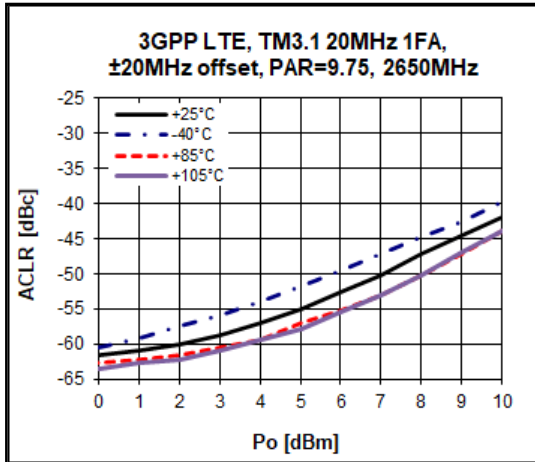

Typical Performance
 ($V_c = 3.3V, I_c = 26mA, T = 25^\circ C$)

Gain Flatness

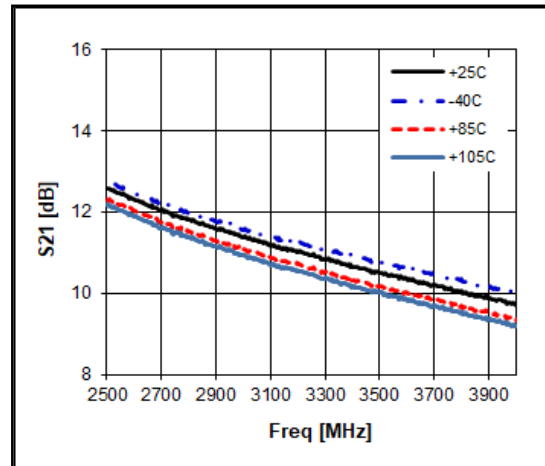
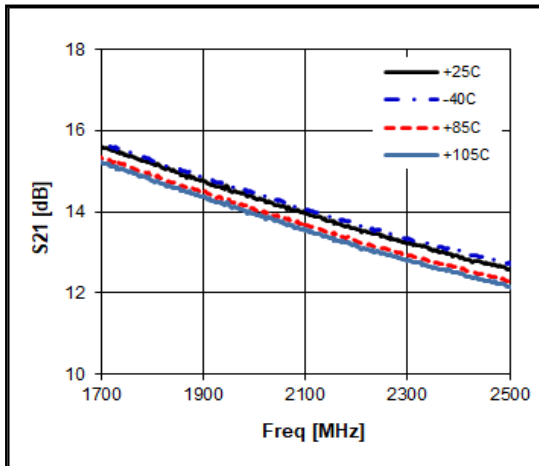
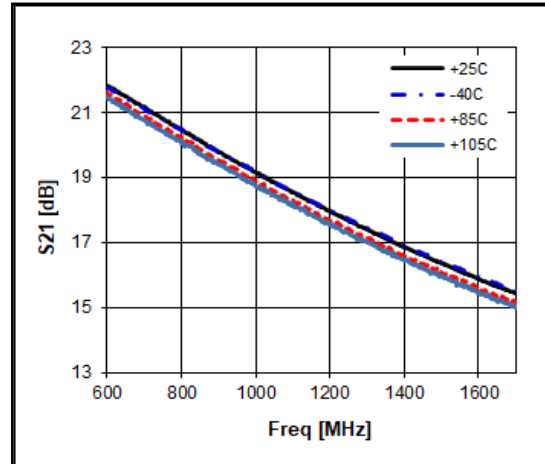
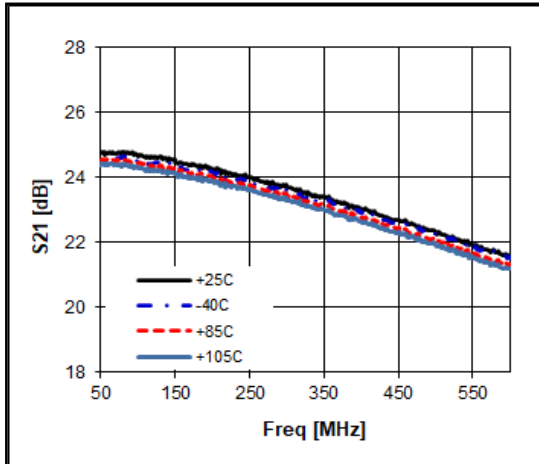

Package Outline Dimension

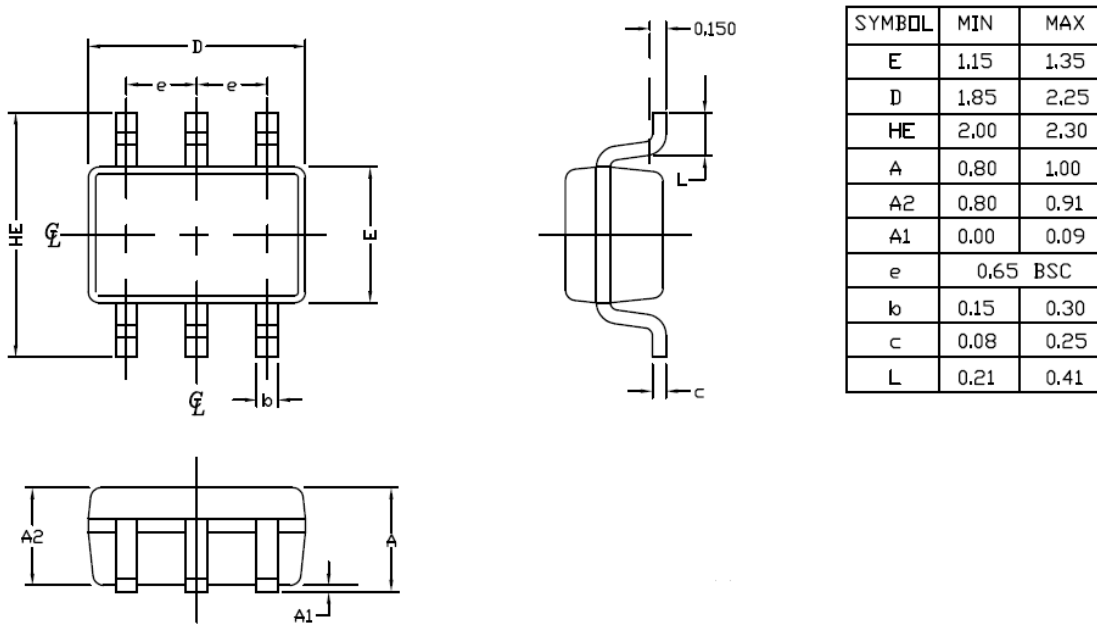

Suggested PCB Land Pattern and PAD Layout

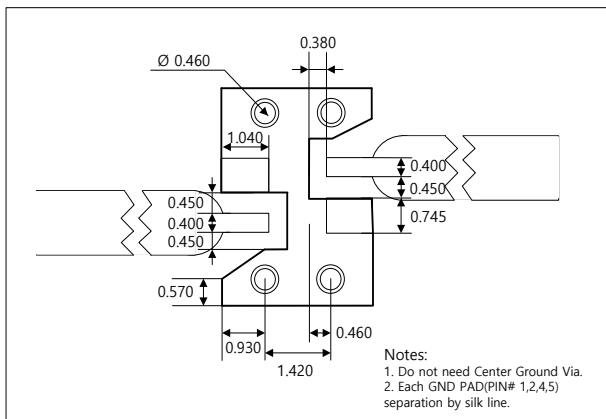
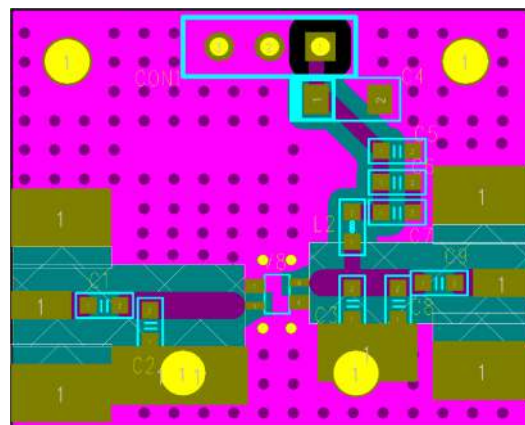
PCB Land Pattern

PCB Mounting

Note : All dimension _ millimeters

PCB lay out _ on BeRex website

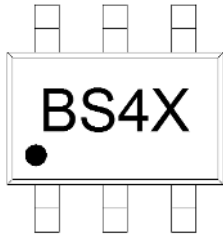
Package Marking



X = Wafer No.

Pin 1

New Package Marking

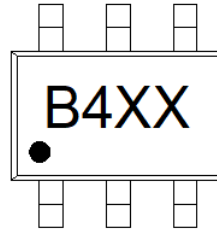

XX = Wafer No.

Pin 1

* Note : New Package marking has been modified from BS4X to B4XX since June 2017.

Tape & Reel

SOT-363

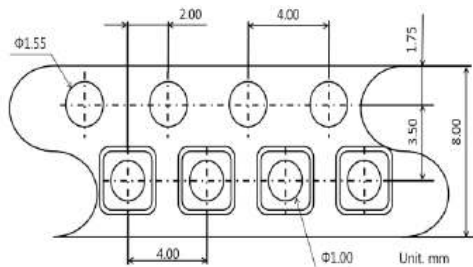

Packaging information:

- Tape Width (mm): 8
- Reel Size (inches): 7
- Device Cavity Pitch (mm): 4
- Devices Per Reel: 3000

Lead plating finish

100% Tin Matte finish

(All BeRex products undergoes a 1 hour, 150 degree C, Anneal bake to eliminate thin whisker growth concerns.)

MSL / ESD Rating

ESD Rating: Class 1C
Value: Passes <2000V
Test: Human Body Model (HBM)
Standard: JEDEC Standard JS-001-2012

MSL Rating: Level 1 at +260°C convection reflow
Standard: JEDEC Standard J-STD-020



Proper ESD procedures should be followed when handling this device.

RoHS Compliance

This part is compliant with Restrictions on the Use of Certain Hazardous Substances in Electrical and Electronic Equipment (RoHS) Directive 2011/65/EU as amended by Directive 2015/863/EU.

This product also is compliant with a concentration of the Substances of Very High Concern (SVHC) candidate list which are contained in a quantity of less than 0.1%(w/w) in each components of a product and/or its packaging placed on the European Community market by the BeRex and Suppliers.

NATO CAGE code:

2	N	9	6	F
---	---	---	---	---