

PART NAME	UTILIBOX (STYLE A)	PART No.	CU-3281 thru CU-3284 and CU-3287 CUR-3281 thru CUR-3284 and CUR-3287 CUR-3281-C thru CUR-3284-C & CUR-3287-C	REV. DATE	9-2-10
-----------	--------------------	----------	--	-----------	--------

MATERIAL:

BODY AND STANDARD COVERS

ABS THERMOPLASTIC (FLAMMABILITY RATING UL94-5VA)

RECESSED COVERS (CUR-)

ABS THERMOPLASTIC (FLAMMABILITY RATING UL94V-0)

CLEAR COVERS (-C)

ABS THERMOPLASTIC (FLAMMABILITY RATING UL94V-2)

FINISH

BODY AND STANDARD COVERS ARE BLACK TEXTURED

RECESSED (CUR-) AND CLEAR COVERS (-C) ARE SMOOTH FINISH

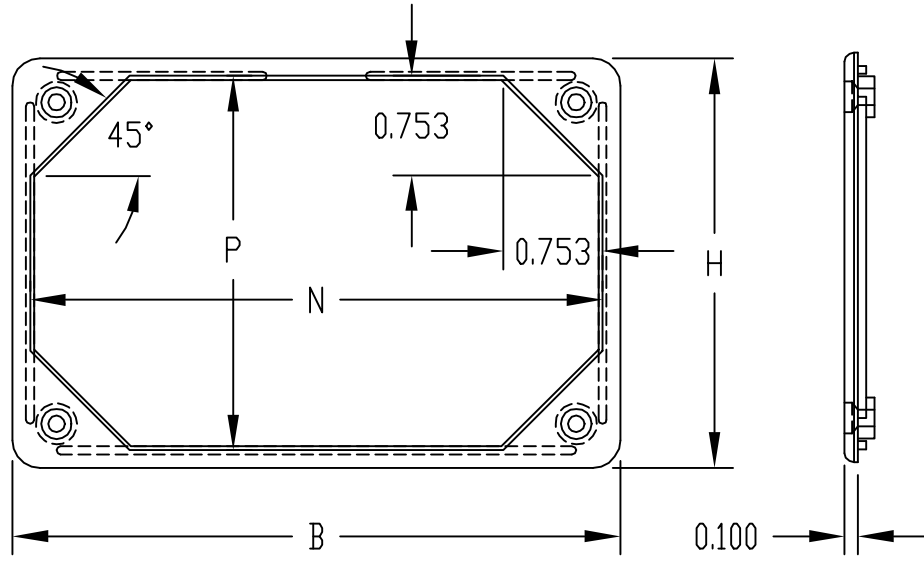

FOUR (4) #4-40 x 0.375" LG. SCREWS SUPPLIED FOR ASSEMBLING COVER TO BODY

MOUNTING BOSSES USE EITHER M2.5 METRIC OR #4 STD. SHEET METAL SCREWS x 0.250" LG. (NOT SUPPLIED)

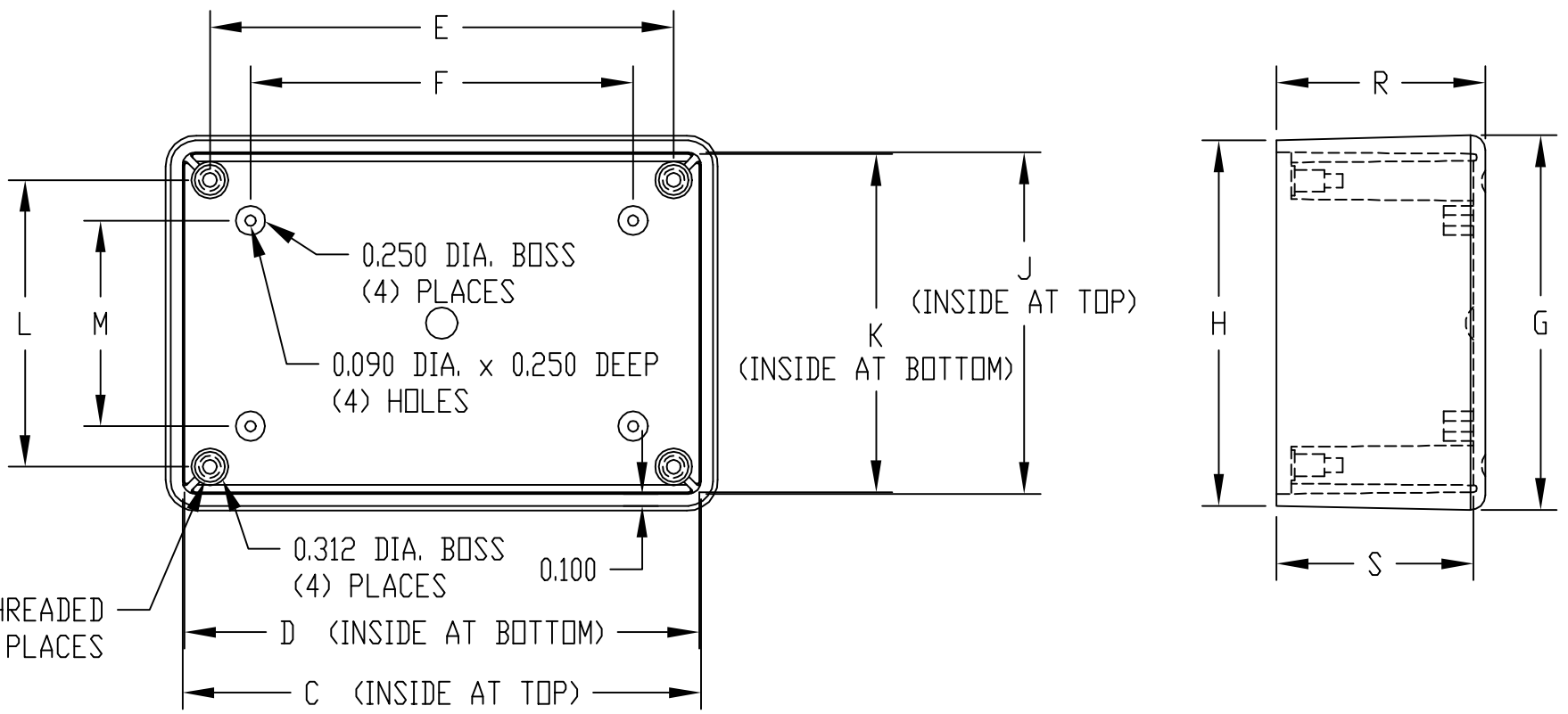

#4-40 THREADED INSERT (4) PLACES

NOTE: ALL DIMENSIONS HAVE ±0.010 TOLERANCE UNLESS OTHERWISE SPECIFIED

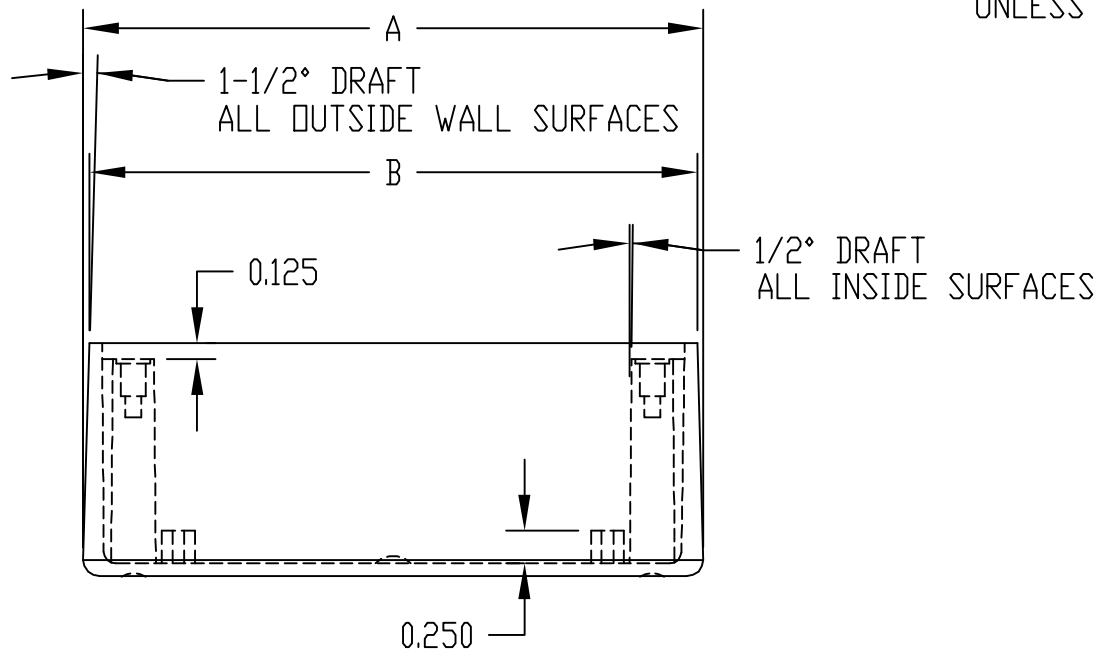

PART No.	A	B	C	D	E	F	G	H	J	K	L	M	N	P	R	S
CU-3281	4.690	4.604	4.404	4.375	3.938	3.250	3.190	3.104	2.904	2.875	2.438	1.750	4.337	2.837	1.772	1.672
CU-3282	4.724	4.612	4.412	4.375	3.938	3.250	4.724	4.612	4.412	4.375	3.938	3.250	4.345	4.345	2.256	2.156
CU-3283	6.224	6.112	5.912	5.875	5.438	4.750	4.724	4.612	4.412	4.375	3.938	3.250	5.845	4.345	2.256	2.156
CU-3284	7.724	7.612	7.412	7.375	6.938	6.250	4.724	4.612	4.412	4.375	3.938	3.250	7.345	4.345	2.256	2.156
CU-3287	6.224	6.112	5.912	5.875	5.438	4.750	4.724	4.612	4.412	4.375	3.938	3.250	5.845	4.345	1.250	1.156