



*The picture shows EA DEMOPACK-RELAY
Display dimension 84x58x12mm*

FEATURES

- 2.8" SMART TOUCH DISPLAY, IPS TECHNOLOGY
- SUPER BRIGHT >1000cd/m²
- INTEGRATED HMI CONTROLLER
- WYSIWYG EDITOR FOR WINDOWS
- INDUSTRIAL GRADE DISPLAY
- PCAP TOUCHPANEL OPTICALLY BONDED
- HIGH CONTRAST TFT PANEL
- USB, RS-232, SPI, I²C INTERFACE
- WIDE TEMPERATURE RANGE (T_{OP} -20 .. +70°C)

ORDERING CODES

1x SMART TOUCH 2.8"...

PLUS RGB-LED AND POTI FOR ANALOGUE INPUT

PLUS HUMIDITY, TEMPERATURE AND CO₂ SENSOR

PLUS LEVEL SHIFTER FOR SPI, I²C, RS232, RS485/422 AND 5~30V REG.

PLUS RELAY OUTPUT, ANALOGUE/DIGITAL INPUT AND 5~30V REG.

PLUS WIFI / BLUETOOTH SUPPORT, ESP32 BUILD-IN AND 5~28V REG.

PLUS WIFI / BLUETOOTH / ETHERNET, ESP32 BUILD-IN, 5~28V REG.

EA DEMOPACK-RGBANA

EA DEMOPACK-CLIMA

EA DEMOPACK-CONNI

EA DEMOPACK-RELAY

EA DEMOPACK-WIFIBT

EA DEMOPACK-LAN

SPARE PARTS (ALSO GOOD FOR uniTFTs020/035/043)

APPLICATION BOARD WITH RGB LED AND POTI

APPLICATION BOARD WITH HUMIDITY, TEMP. AND CO₂ SENSOR

APPLICATION BOARD WITH LEVEL SHIFTER AND 5~30V REG.

APPLICATION BOARD WITH RELAY OUTPUT, I/O AND 5~30V REG.

APPLICATION BOARD WITH ESP32-WROOM-32 AND 5~28V REG.

APPLICATION BOARD WITH ESP32-WROOM-32 AND 5~28V REG.

APPLICATION BOARD WITH 5~30V REGULATOR

FPC CABLE 40 LINES, 0.5mm PITCH, 102mm

FPC CABLE 40 LINES, 0.5mm PITCH, 51mm

D-SUB9 CONNECTOR FOR EA 94998-CONNI

MINI USB CABLE, ABOUT 1m

EA 94998-RGBANA

EA 94998-CLIMA

EA 94998-CONNI

EA 94998-RELAY

EA 94998-WIFIBT

EA 94998-LAN

EA 94998-POWER

EA KF050-40

EA KF050-40L51

EA D-SUB9LPB

EA KUSB-MINI

CONTENT

FEATURES.....	1
ORDERING CODES.....	1
Spare Parts (also good for uniTFTs020/035/043)	1
OVERVIEW - 2.8" SMART TOUCH.....	3
Application boards.....	3
Power supply.....	3
Spare parts EA 94998-xxx	3
How to connect the Display.....	4
How to connect the Application board.....	4
Power on	4
WYSIWYG Editor	5
Pinout 2x20 pin eyelet.....	6
EA DEMOPACK-RGBANA	7
Schematic	7
Dimension	8
Connection	8
EA DEMOPACK-CONNI.....	9
Schematic	9
Dimension	10
Connection	10
EA DEMOPACK-RELAY	11
Schematic	11
Dimension	12
Connection	12
EA DEMOPACK-CLIMA	13
Schematic	13
Dimension	14
Connection	14
EA DEMOPACK-WiFiBT / -LAN	15
Schematic	15
Dimension	16
Connection	16
EA 94998-POWER	17
Schematic	17
Dimension	18
Outline dimension 2.8" Display	19

OVERVIEW - 2.8" SMART TOUCH

All EA DEMOPACKs come with a 2.8" IPS display incl. PCAP plus an individual application board.

This miniature touch panel is eminently suited to replace physical switches and controllers in home automation, for use as control panels in caravans or for integration into kitchen appliances as well as wellness and fitness equipment. Alongside the USB interface it provides some more typical interfaces, such as RS-232, SPI and I²C. Digital in- and outputs, 4 analogue inputs and a PWM output make it possible to use them as intelligent controllers for calculation and management of data and signals.



APPLICATION BOARDS

Together with the 2.8" display soon there will be several different DEMOPACKs with individual application boards available. These application boards show in an educational way how to connect external sensors and other circuits to the display. All boards are running directly out of the box.

EA DEMOPACK-	Demonstrating
-RGBANA	- Voltage measurement 0..3.3V - RGB LED via SPI output, display is master
-CLIMA	- CO2 Sensor via I ² C - Humidity and temperature sensor via I ² C - RTC with battery backup
-CONNI	- Level Shifter for I ² C, SPI, RS-232, RS-485/422 - Power supply 5~30V=
-RELAY	- 2x Relay output - incl. current measurement up to ±5A - digital input up to 30V - analogue input with voltage divider - Power supply 5~30V=

POWER SUPPLY

There are 3 ways to provide supply voltage to the display:

- Powering up the display requires an external USB charger/power supply. Direct connection to any USB port of your pc is also recommended.
- Alternatively the display may be powered by an external 3.3V supply (typ. 240mA).
- Some Application boards provide a voltage regulator for power supply from 5 to 30V=

SPARE PARTS EA 94998-XXX

If you like to get the applications board without the display then those are called EA 94998-xxx. May be you need it as a spare part to replace a defect one or you like to combine with other display sizes like 2.0", 3.5" and 4.3". Please order display and cable separately in this case.

HOW TO CONNECT THE DISPLAY

First of all, plug in the FPC into ZIF connector of display:

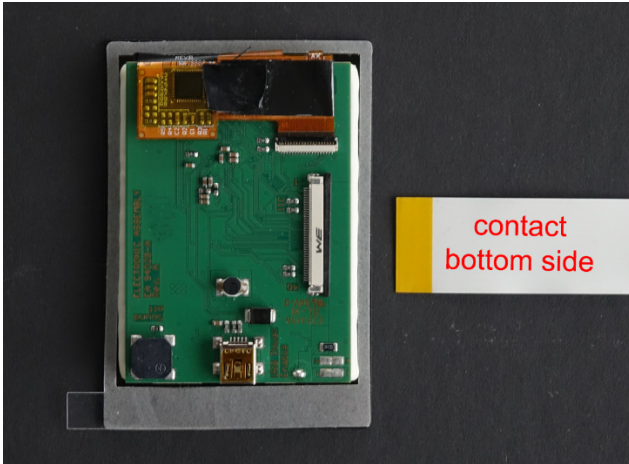

HOW TO CONNECT THE APPLICATION BOARD

Next, plug in the FPC cable into ZIF connector of pcb:

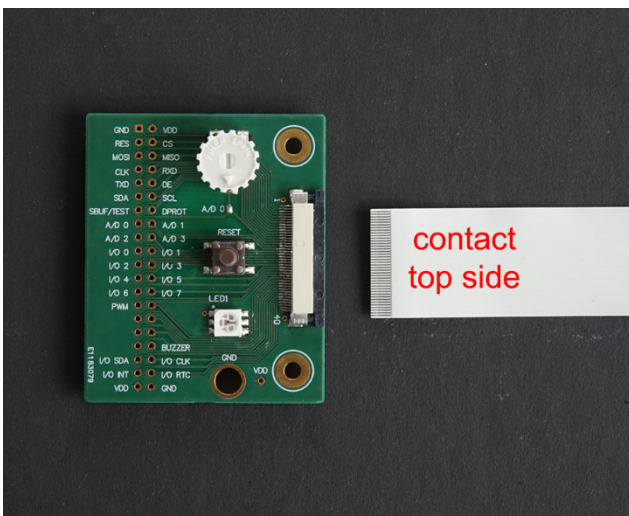

POWER ON

Finally plug in the black USB cable into the displays USB connector or other supply voltage. Display will light up now and you may change measuring voltage by turning the potentiometer. Touching the display changes the function and provides an adjustment of LED color and brightness.

EA DEMOPACK – GENERAL INFORMATION

WYSIWYG EDITOR

We made the graphical design und built-in the function with the *uniTFTDesigner* which is the perfect WYSIWYG editor for Windows. The [Download](#) is available for free here. EA DEMOPACK will come with the relating demo application already installed in display. You may edit the delivered design with *uniTFTDesigner* at any time:

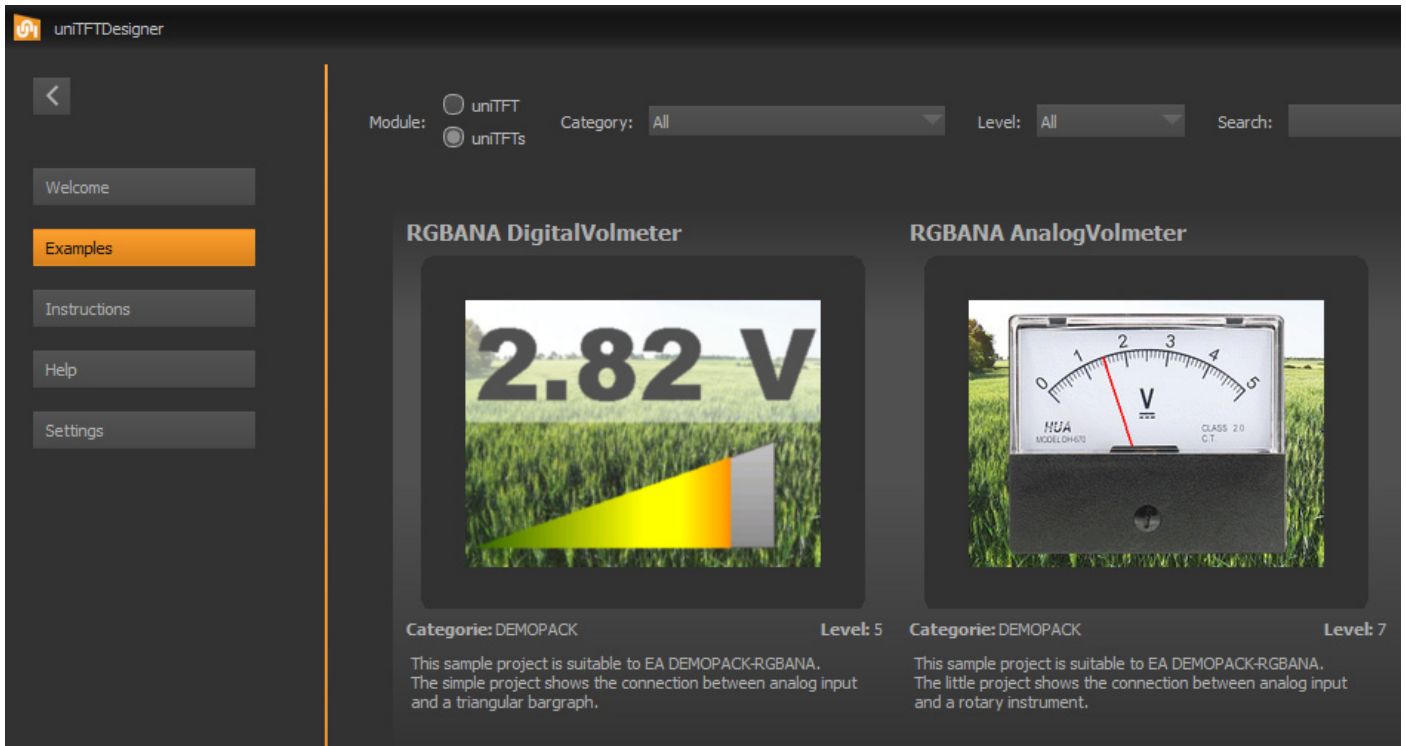

EA DEMOPACK – GENERAL INFORMATION

PINOUT 2X20 PIN EYELET

There's a 40-pin ZIF connector on display (bottom contact) and a 2x20-pin eyelet on application board. Both do provide same pinout. The 2x20 pin eyelet is available for all EA DEMOPACK and EA 94998

Pin	Symbol	I/O	Description	
1	GND		Ground 0 V	
2	VDD		Power Supply 3.3 V	
3	RES	I	Reset	internal Pull-Up: (10..75 kΩ)
4	CS	I	SPI: Chip Select	internal Pull-Up: (1 MΩ)
5	MOSI	I	SPI: MOSI	
6	MISO	O	SPI: MISO	
7	CLK	I	SPI: CLK	internal Pull-Up: (1 MΩ)
8	RxD	I	RS232: Receive Data	internal Pull-Up: (1 MΩ)
9	TxD	O	RS232: Transmit Data	
10	DE	O	RS485: Transmit Enable	
11	SDA	I/O	I ² C: Serial Data	internal Pull-Up: (10 kΩ); Pull-Up resistors can be changed for proper I ² C connection
12	SCL	I	I ² C: Serial Clock	internal Pull-Up: (10 kΩ)
13	SBUF TESTMODE	I	Low: Data available in send buffer PowerOn Low: Test mode	internal Pull-Up: (10 kΩ)
14	DPROT	I	High: Small-/Shortprotokoll active Low: deactivated	internal Pull-Up: (10 kΩ)
15..18	A/D 0..3	I	Analog Input 0..3	internal Pull-Down: (1 MΩ)
19..26	I/O 0.0 .. 0.7	I/O	I/O 0.0 (Bit 0..7)	internal Pull-Up: (1 MΩ), Reset-state: Tri-State, default: input
27	PWM	O	PWM-Output	
28..33	DNC	---	Do not connect	Reserved for future use
34	BUZZER	O	Sound	PWM output for external speaker
35	IO SDA	I/O	I ² C data to portexpander / RTC	Portexpander MCP23017-E can be connected here. For EA uniTFTs020-ATC and EA uniTFTs028-ATC RTC MCP7940N - SN can be connected, too
36	IO CLK	O	I ² C clock to portexpander / RTC	If not used please leave open
37	IO INT	I	Interrupt portexpander	If not used please leave open
38	IO RTC	I	Interrupt RTC	For EA uniTFTs020 and EA uniTFTs028 only. If not used please leave open. EA uniTFTs035 and EA uniTFTs043: internally connected, for –CLIMA remove 2x RTC resistors
39	VDD		Power Supply 3.3 V	
40	GND		Ground 0 V	

EA DEMOPACK-RGBANA

The DEMOPACK-RGBANA includes a display and a board with RGB LED and potentiometer. It demonstrates how the display drives an external component via SPI interface (here a RGB LED). For that we're using the LED [APA102C](#). The demopack also demonstrates how to measure an analogue voltage via display input line "A/D 0".



In addition there's a reset button onboard. The schematic below shows that there are less external components necessary.

SCHEMATIC

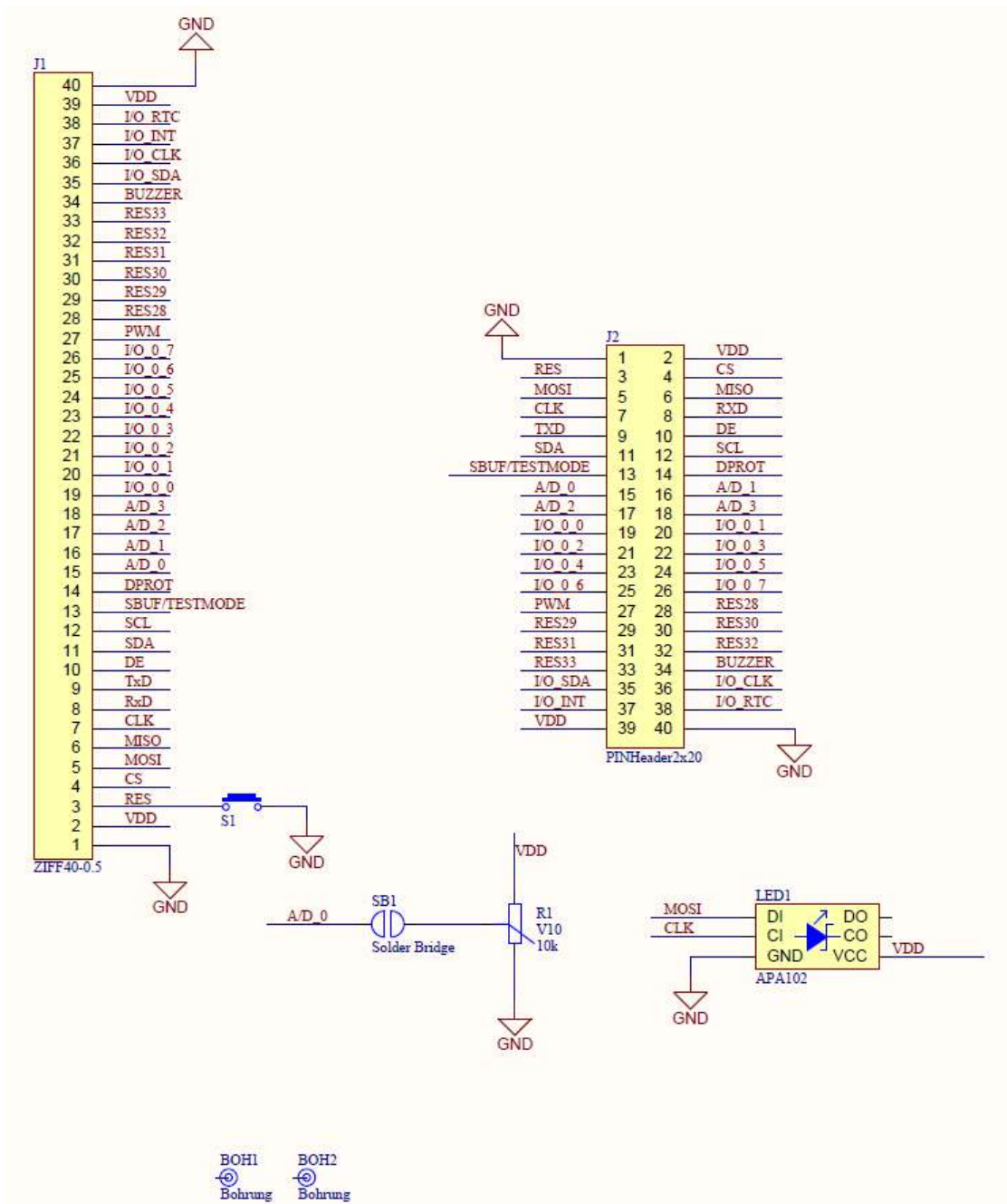

DIMENSION

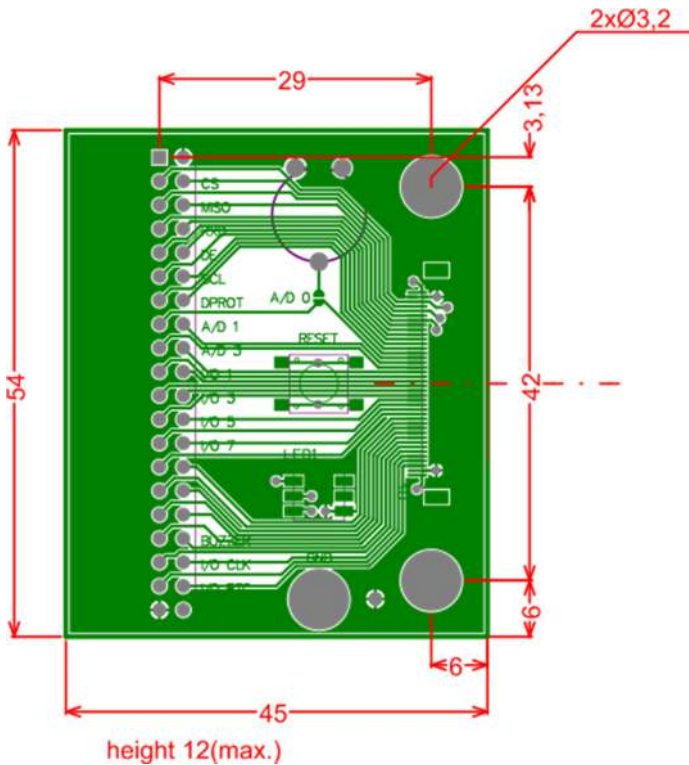

All dimensions in mm.

If you are interested, we provide all production data incl. ALTIUM layout on our [website](#).

CONNECTION

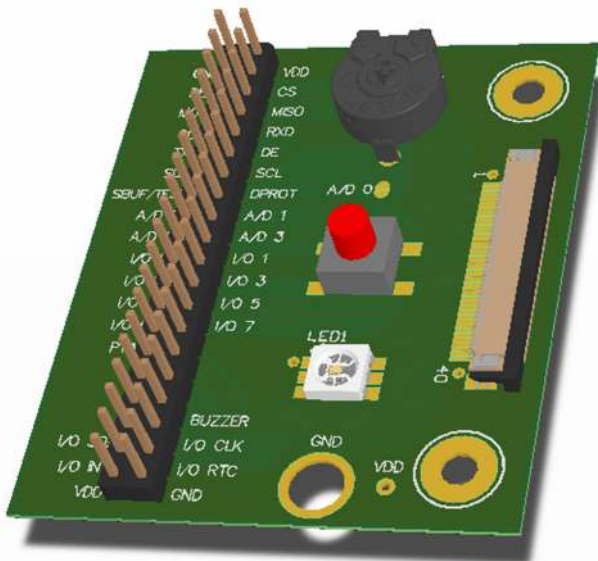

Note: Illustration shows a fully assembled pcb including optional components. Some components are not assembled ex factory.

EA DEMOPACK-CONNI

The DEMOPACK-CONNI includes a display and a board with many level shifter components. Because the display provides 3.3V level at all in- and outputs, it may be necessary to adapt to a 5V system e.g.



Also RS-232 signals at display are 3.3V level; this application board provides a level shifter for ±12V level (for pc).

The RS-485 driver chip allows direct connection to any RS-485 bus. Also good for RS-422.

Attention: RS-232 and RS-485/422 are alternative options. Short solder links SB1 and SB3 for RS-485/422 option to prevent data crash.

An onboard voltage regulator allows supply voltages from 5~30V=.

SCHEMATIC

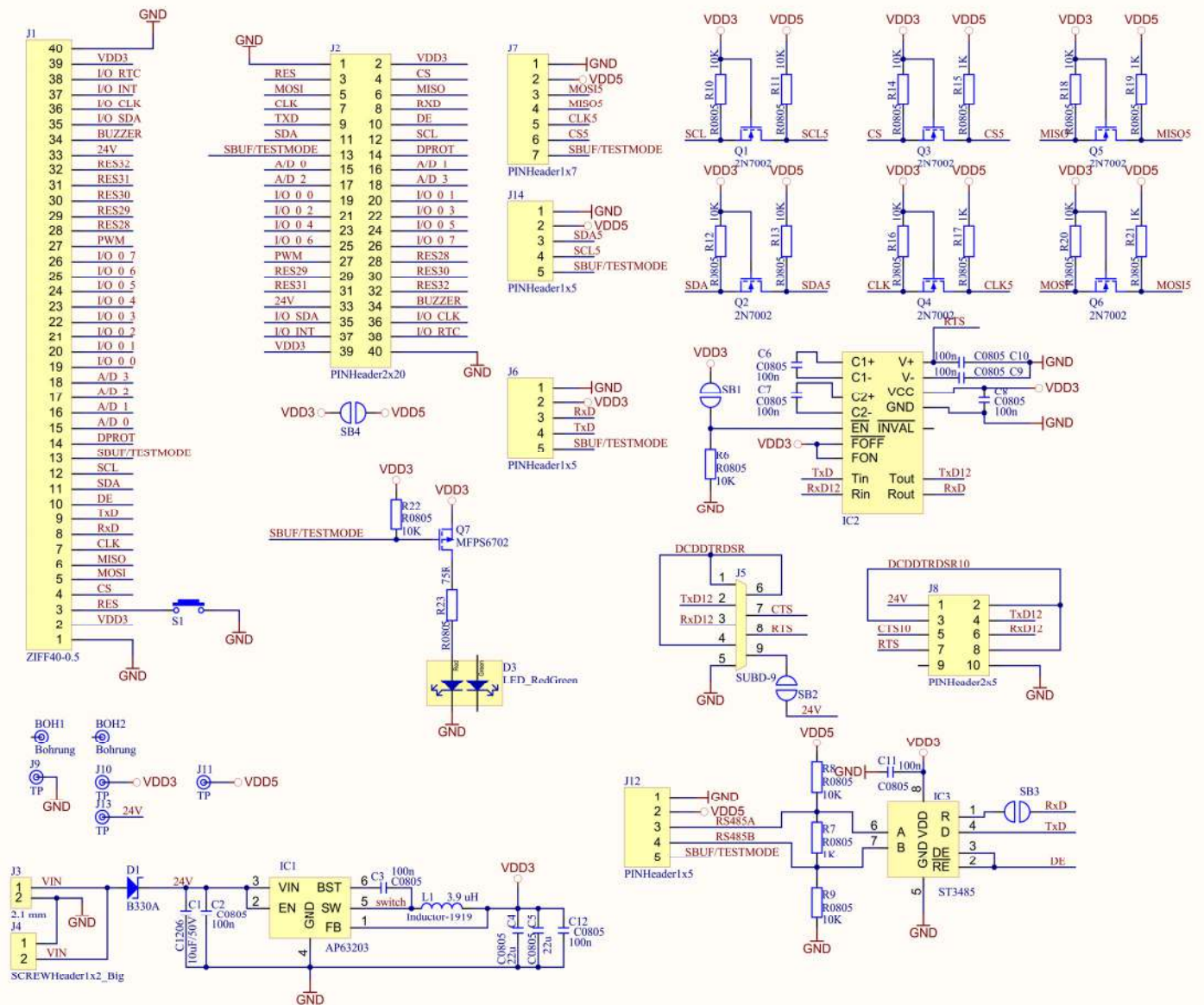

DIMENSION

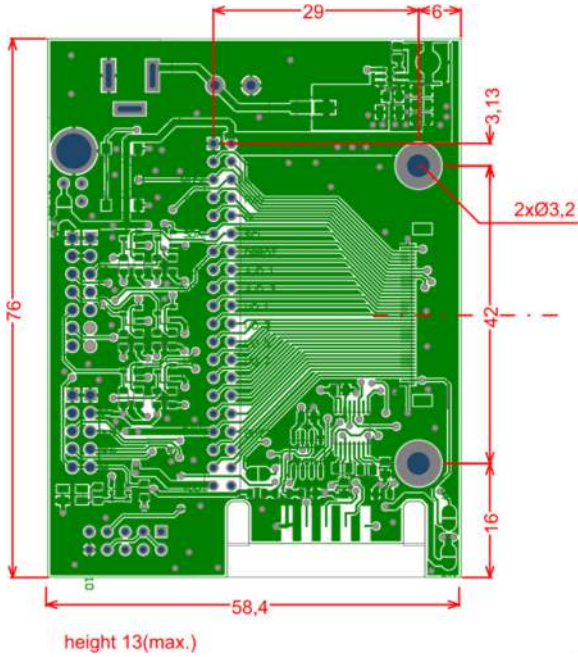

CONNECTION

Solder Bridge VDD <-> VDD5 (SB4)
Close to short circuit VDD (max. 3.3V) to VDD5 (5V)
The SPI and I²C level shifter use VDD5 as H-level

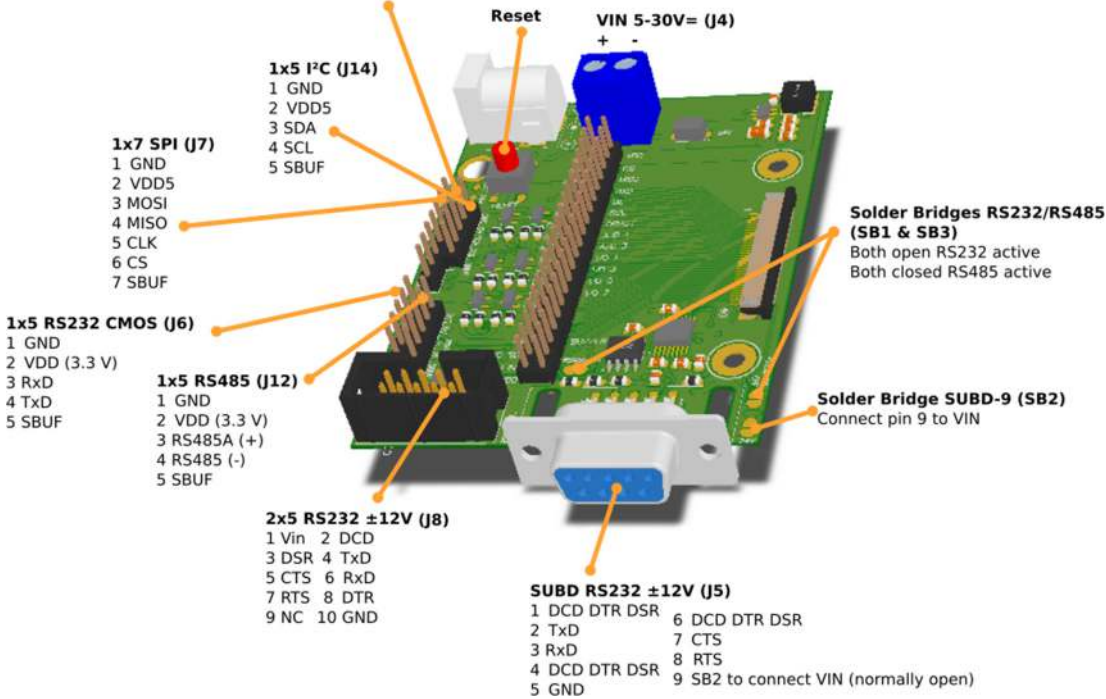

Note: Illustration shows a fully assembled pcb including optional components. Some components are not assembled ex factory.

EA DEMOPACK-RELAY

The DEMOPACK-RELAY includes a display, a fan and an evaluation board with 1 relay output and current measurement (up to $\pm 5A$). There's some space and routing for a 2nd relay. It provides also 4 digital inputs for signals up to 30V.



The 2 analogue inputs are open to measure external voltages of 0..+3.3V or higher with onboard voltage divider.

Power supply is 5~30V= at screw terminal J5. We suggest to provide around 12V= if provided fan is used. An onboard voltage regulator generates 3.3V (VDD) for display and relay.

SCHEMATIC

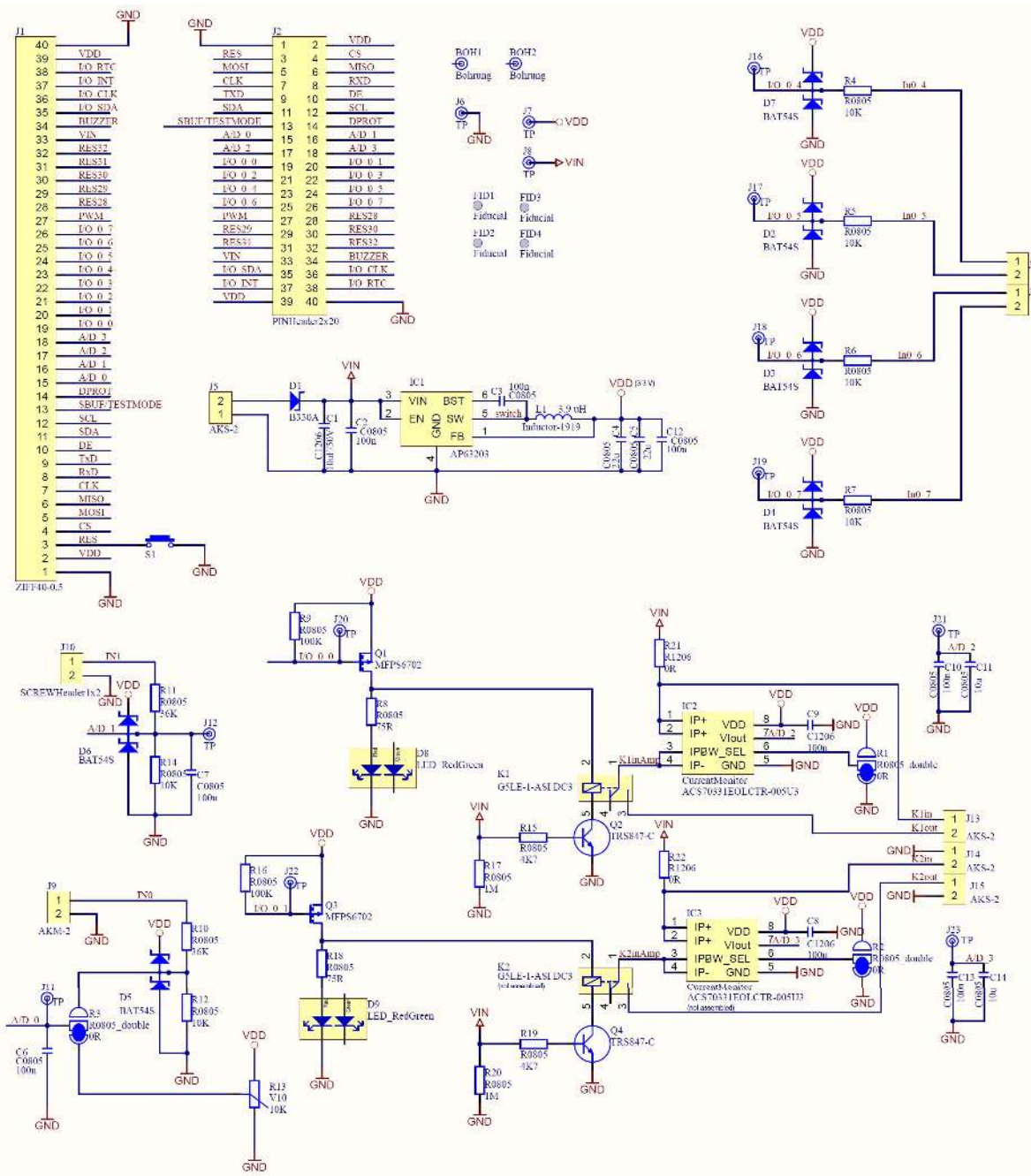

DIMENSION

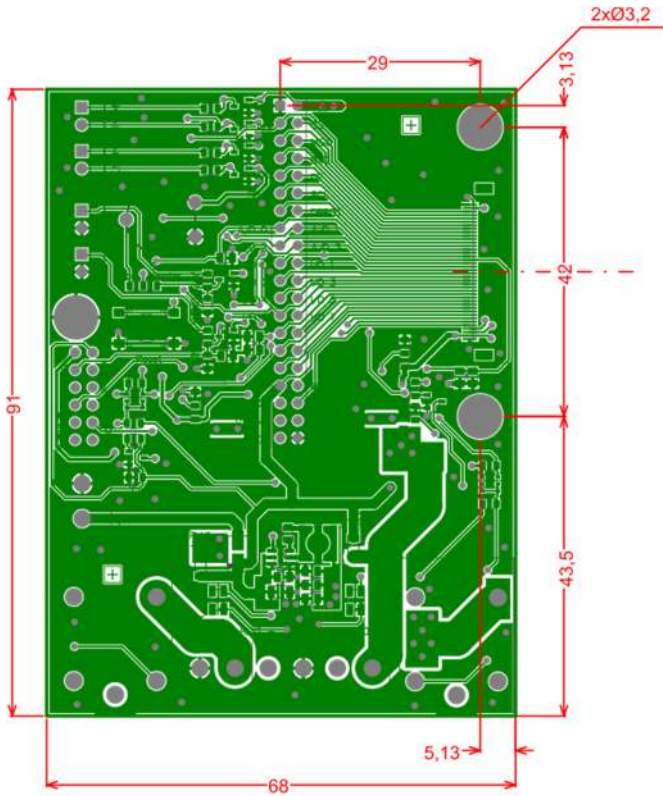

height 22(max.)

All dimensions in mm.

CONNECTION

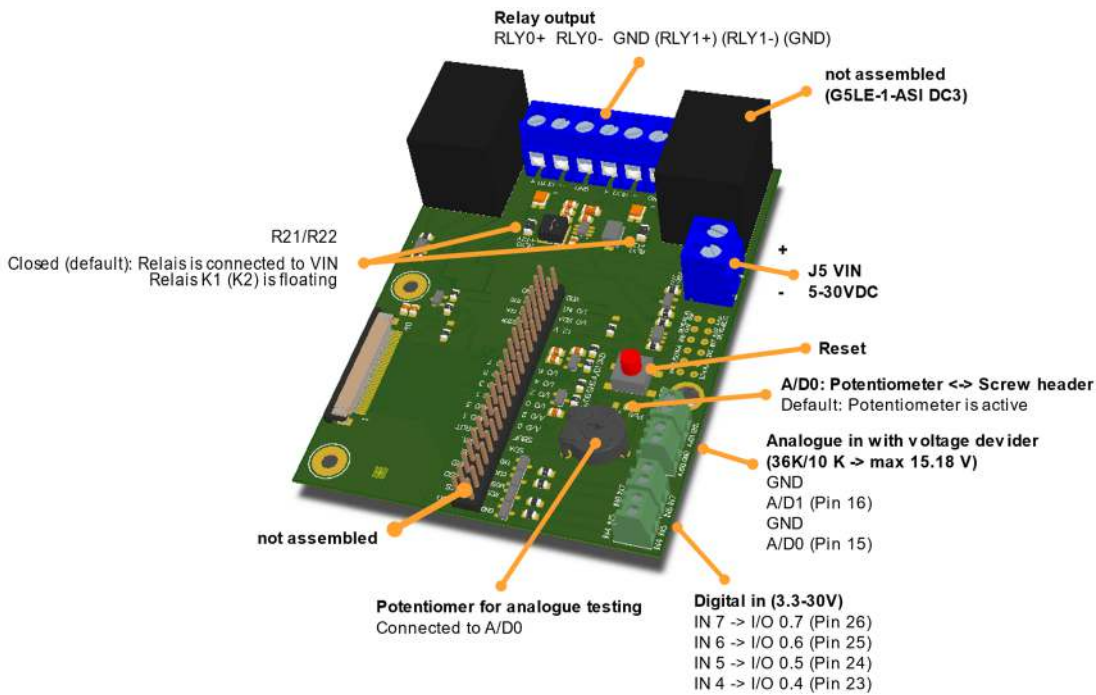

Note: Illustration shows a fully assembled pcb including optional components. Some components are not assembled ex factory (e.g. 1 relay)

EA DEMOPACK-CLIMA

The DEMOPACK-CLIMA includes a display and an evaluation board with environmental sensors, such as temperature, humidity and gas sensor for monitoring indoor air quality, equivalent to CO₂ values.

Together with the build-in RTC the DEMOPACK-CLIMA can also be used for data recording.

For measuring temperature and humidity, we use a Silicon Labs Si7020-A20 I²C sensor.

For measuring CO₂ concentration we use an AMS CCS811B-JOPD500. The device is designed to monitor indoor air quality. The address pin is set to GND per default, which leads to address 0x5A (8-Bit: 0xB4), see R3.

Note: EA DEMOPACK-CLIMA is designed to illustrate the use of I²C master interface. It is not a precision measuring instrument. The values differ depending on the temperature and humidity range.

Note for usage with EA uniTFTs035/043: remove R4 and R5 before use ("Disable RTC") because another RTC is assembled on display already.

SCHEMATIC

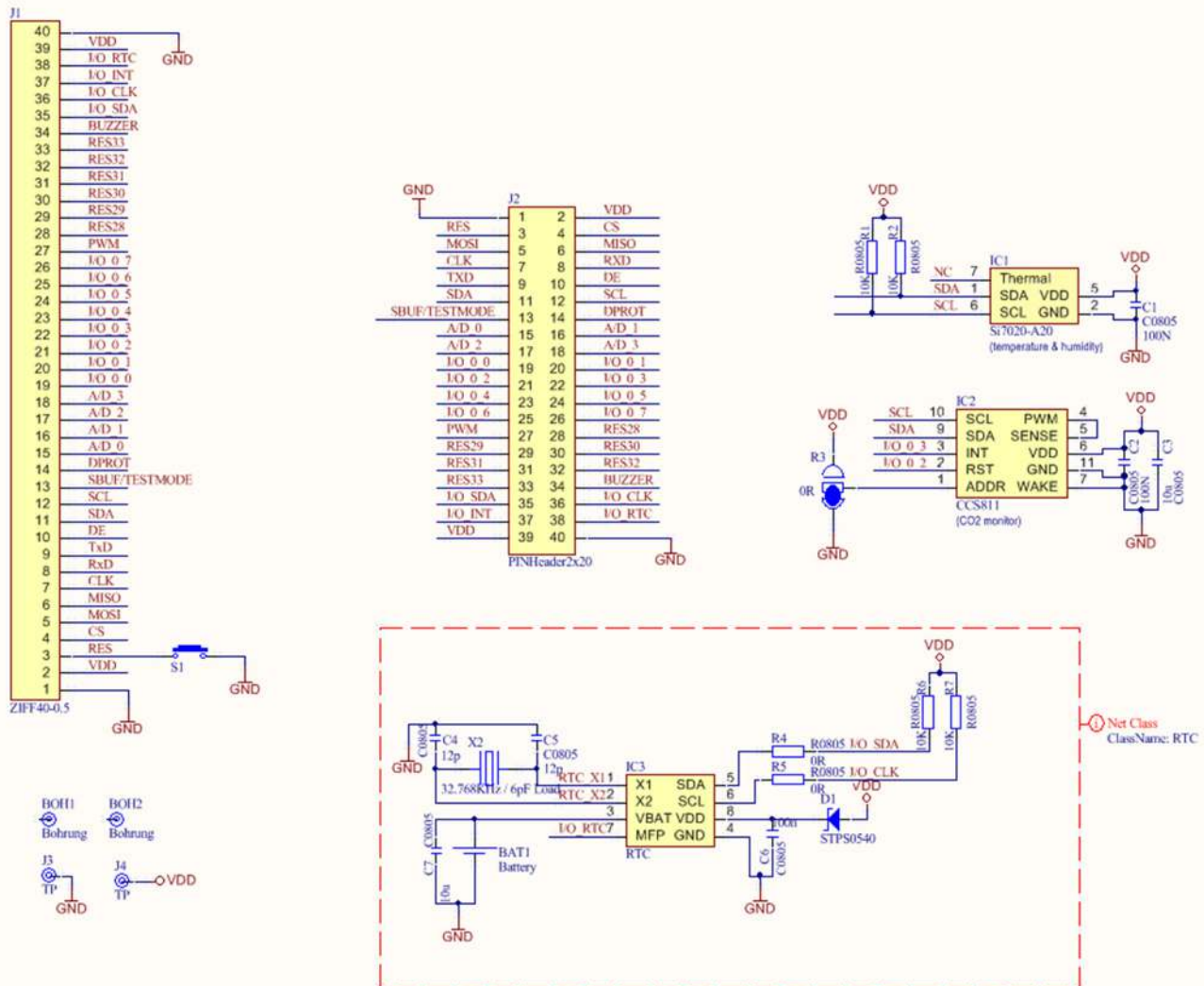

DIMENSION

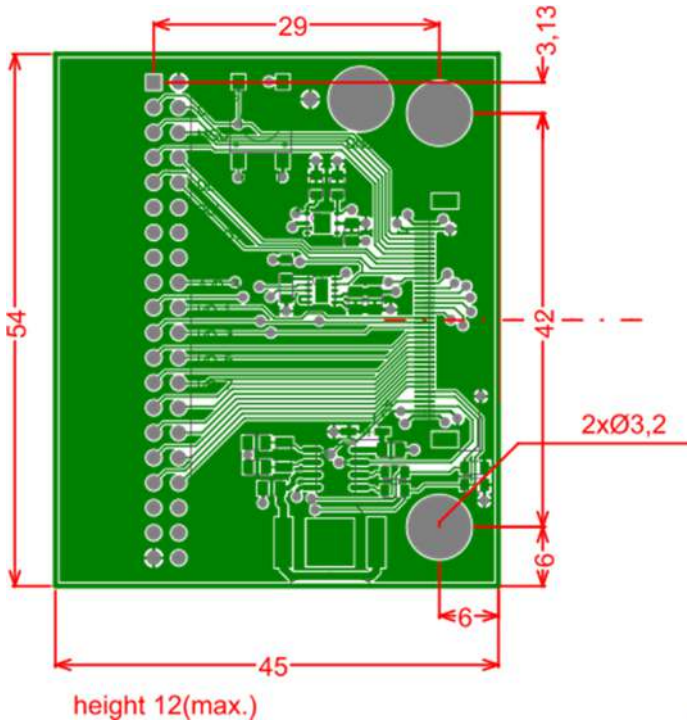

CONNECTION

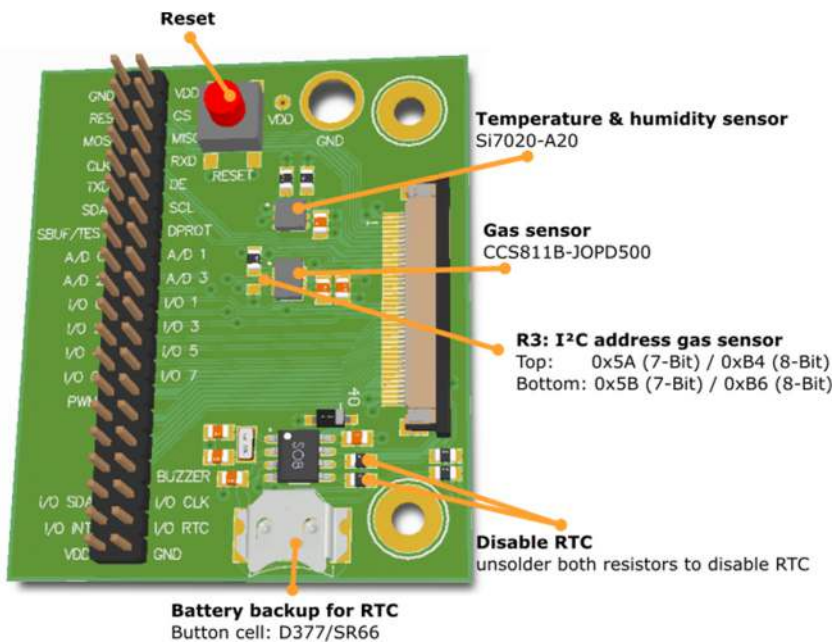

Note: Illustration shows a fully assembled pcb including optional components. Some components are not assembled ex factory.

EA DEMOPACK-WiFiBT / -LAN

The DEMOPACK-WiFiBT illustrates the possibility to access the EA uniTFTs-Series through the air. It includes the famous ESP32 to access Wi-Fi or Bluetooth. We've a fully documented project for the ESP32, running the Arduino IDE as programming front end. Just adopt to your needs. Several uniTFT-Projects are available, like using the EA uniTFTs as Bluetooth keyboard for your smart phone or even for hotkeys for your computer. Another example shows Wi-Fi access, downloading weather information from the web (<https://openweathermap.org>), presenting current weather and forecast worldwide on your EA uniTFTs-module.

The ESP32-WROOM-32 is directly connected to the RS232 interface of the EA uniTFTs-Module. Additionally, the SBUF-out is connected to ESP32's IO 32. The SBUF pin indicates data is present in EA uniTFTs' send buffer. EA uniTFTs' I/O 0.0 is connected to ESP32 I/O 33 for general purposes, e.g. to interrupt direct Bluetooth serial connection. If the ESP32 performs a reset, the EA uniTFTs-Module is reset, too.

An onboard voltage regulator allows supply voltages from 5~28V=.

Note: J4, RJ45 connector with magnetics is not assembled in the EA DEMOPACK-WiFiBT, please order EA DEMOPACK-LAN instead.

SCHEMATIC

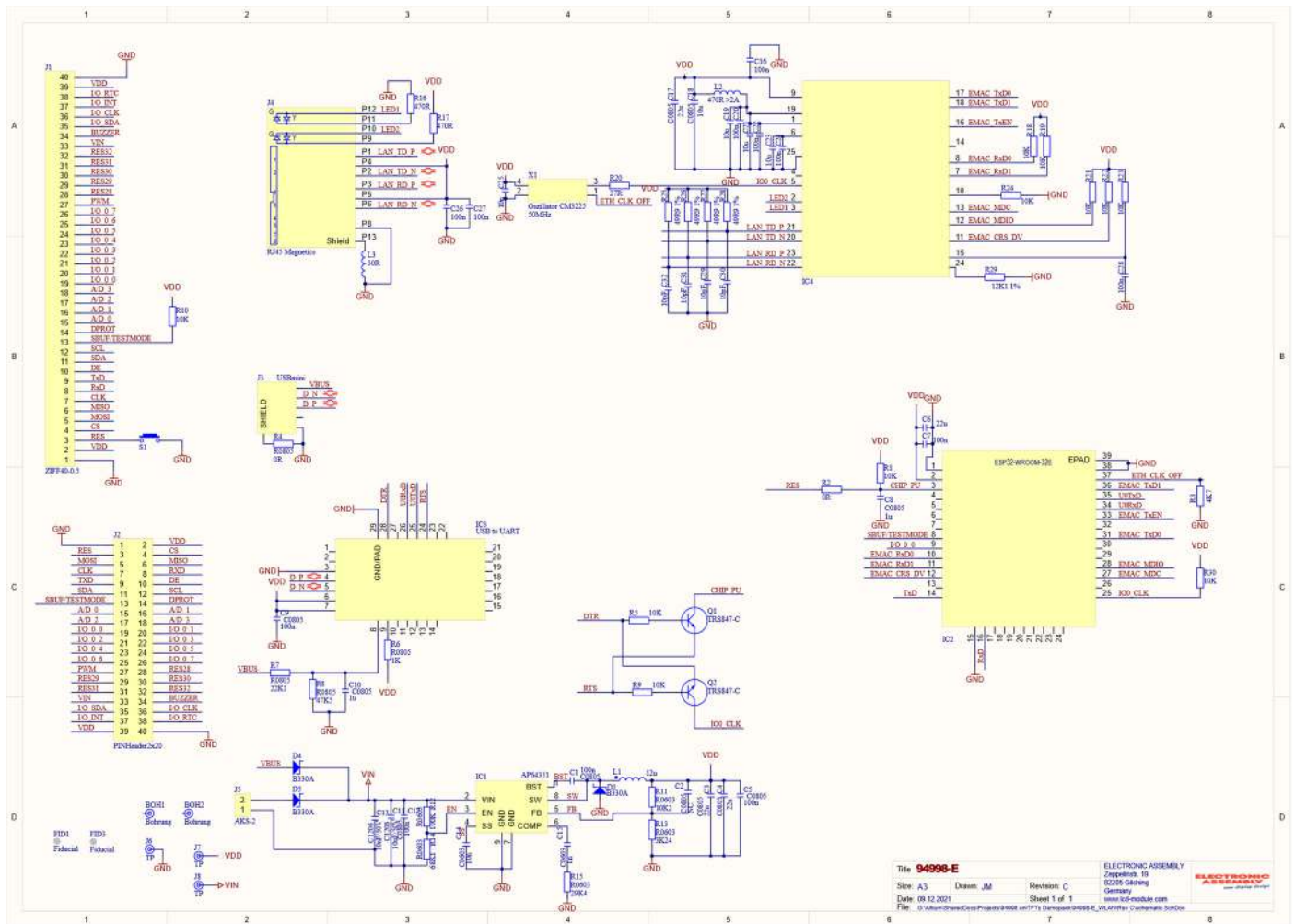

DIMENSION

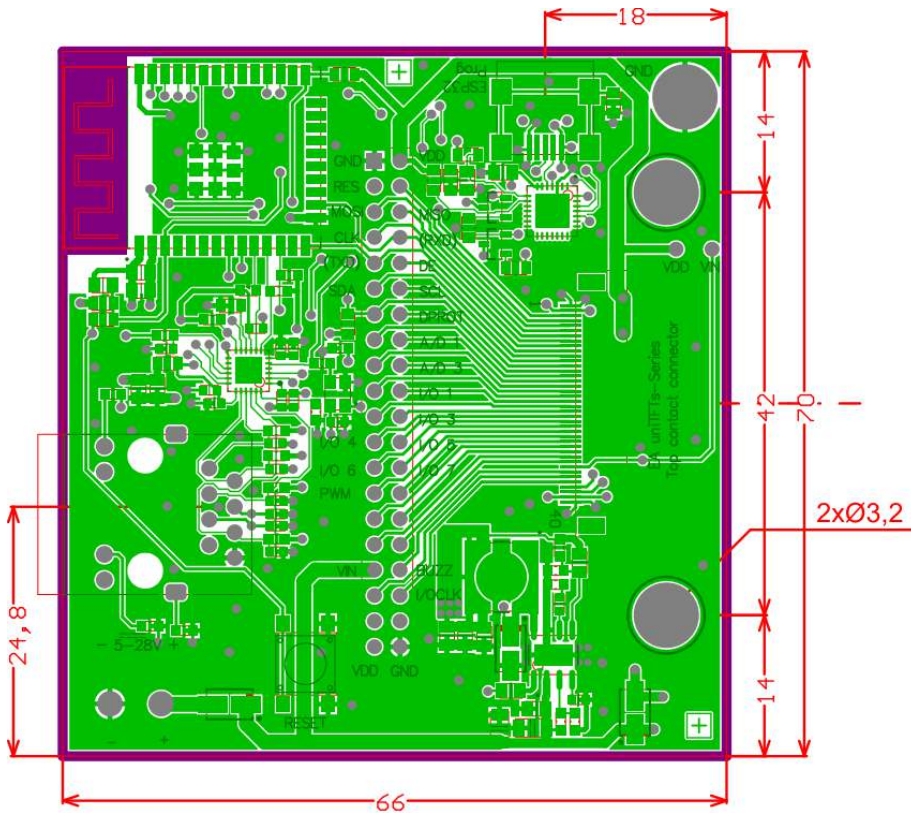

CONNECTION

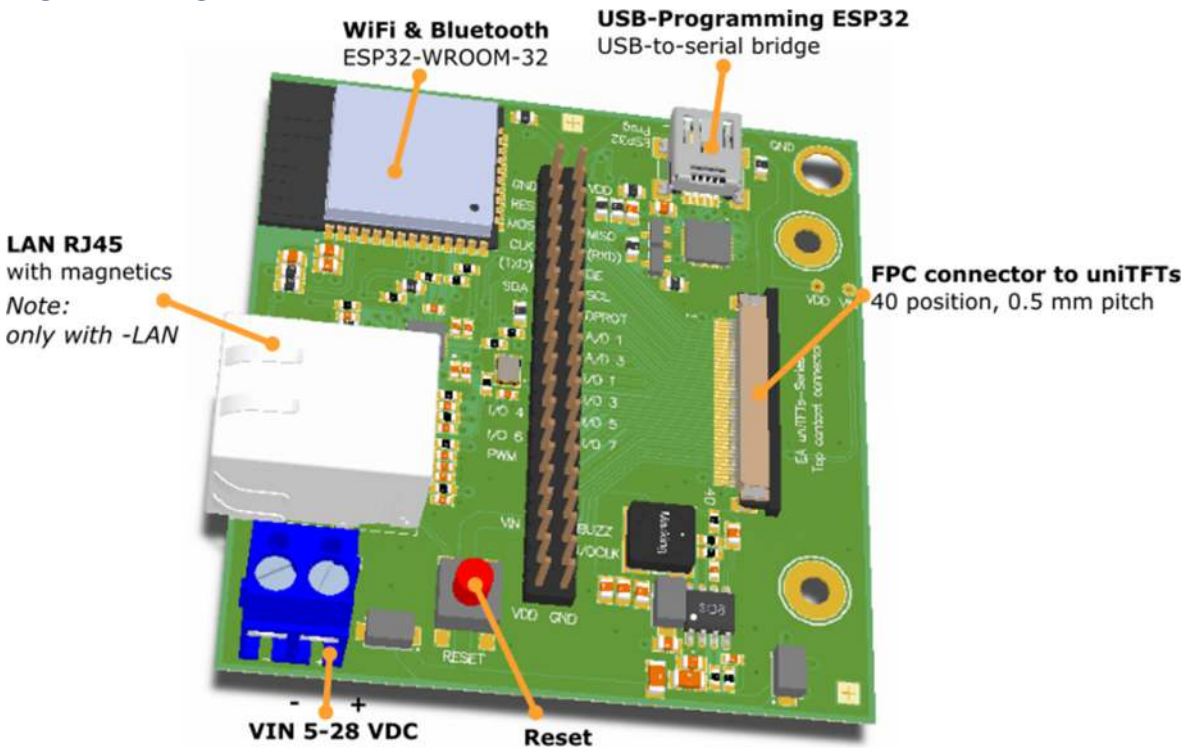

EA 94998-POWER

The EA 94998-POWER comes with an onboard voltage regulator. It allows supply voltages from 5 to 30V= and provides stabilized 3.3V to the ZIF connector e.g. for all displays in EA unitTFTs family.



SCHEMATIC

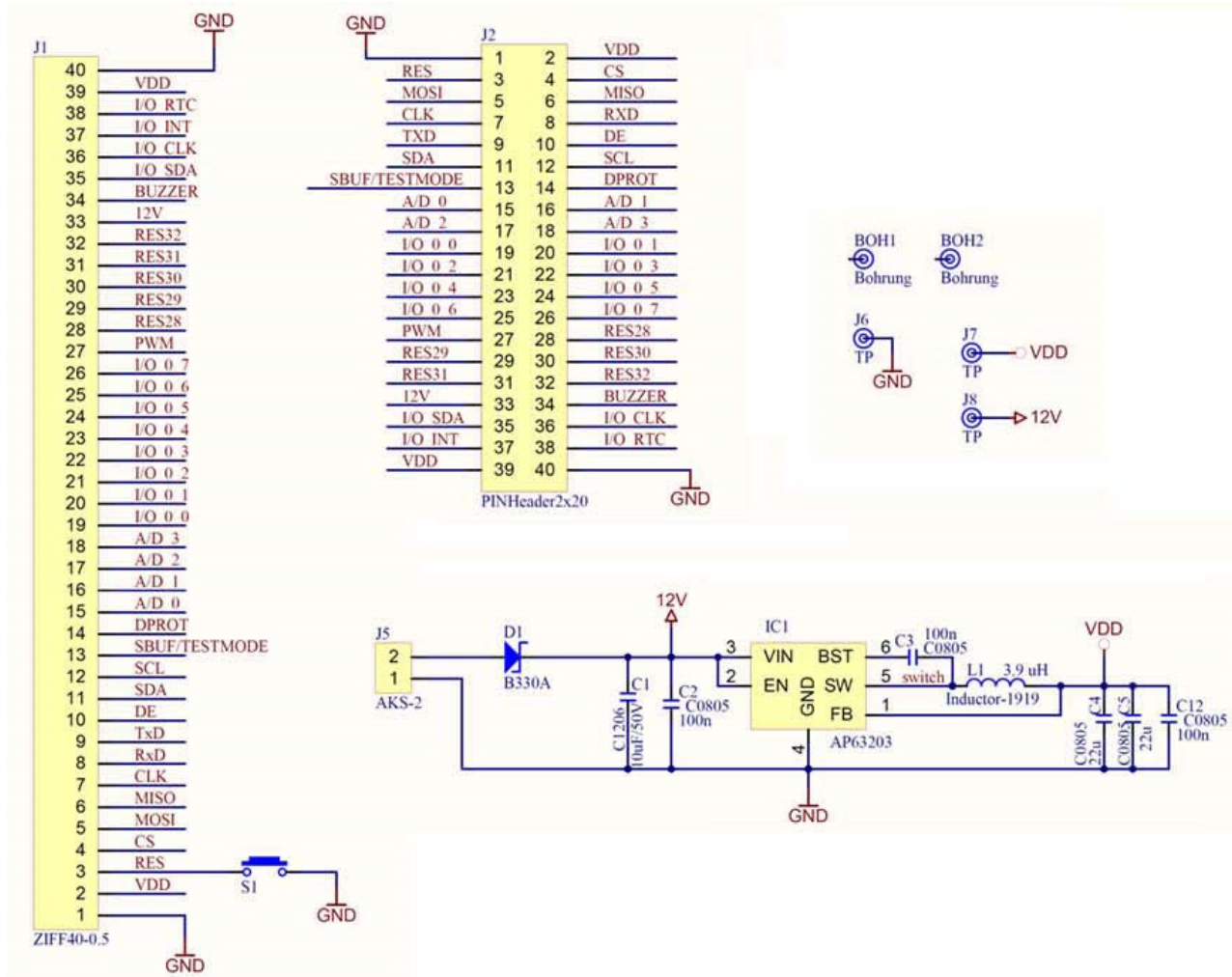

DIMENSION

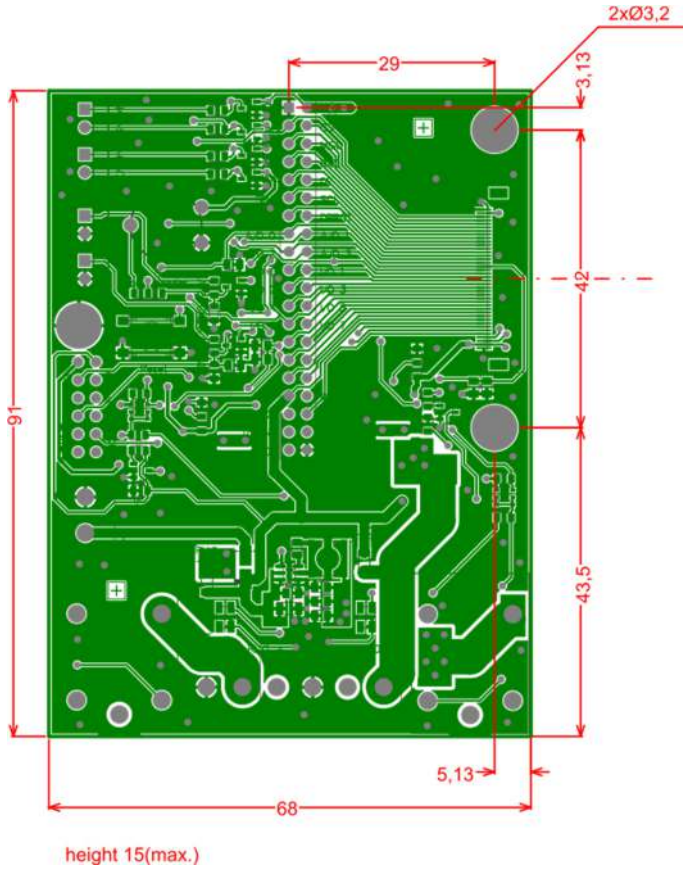

All dimensions in mm.

OUTLINE DIMENSION 2.8" DISPLAY

Every EA DEMOPACK-xxx comes with an intelligent HMI display unit incl. touchpanel EA uniTFTs028-ATC.

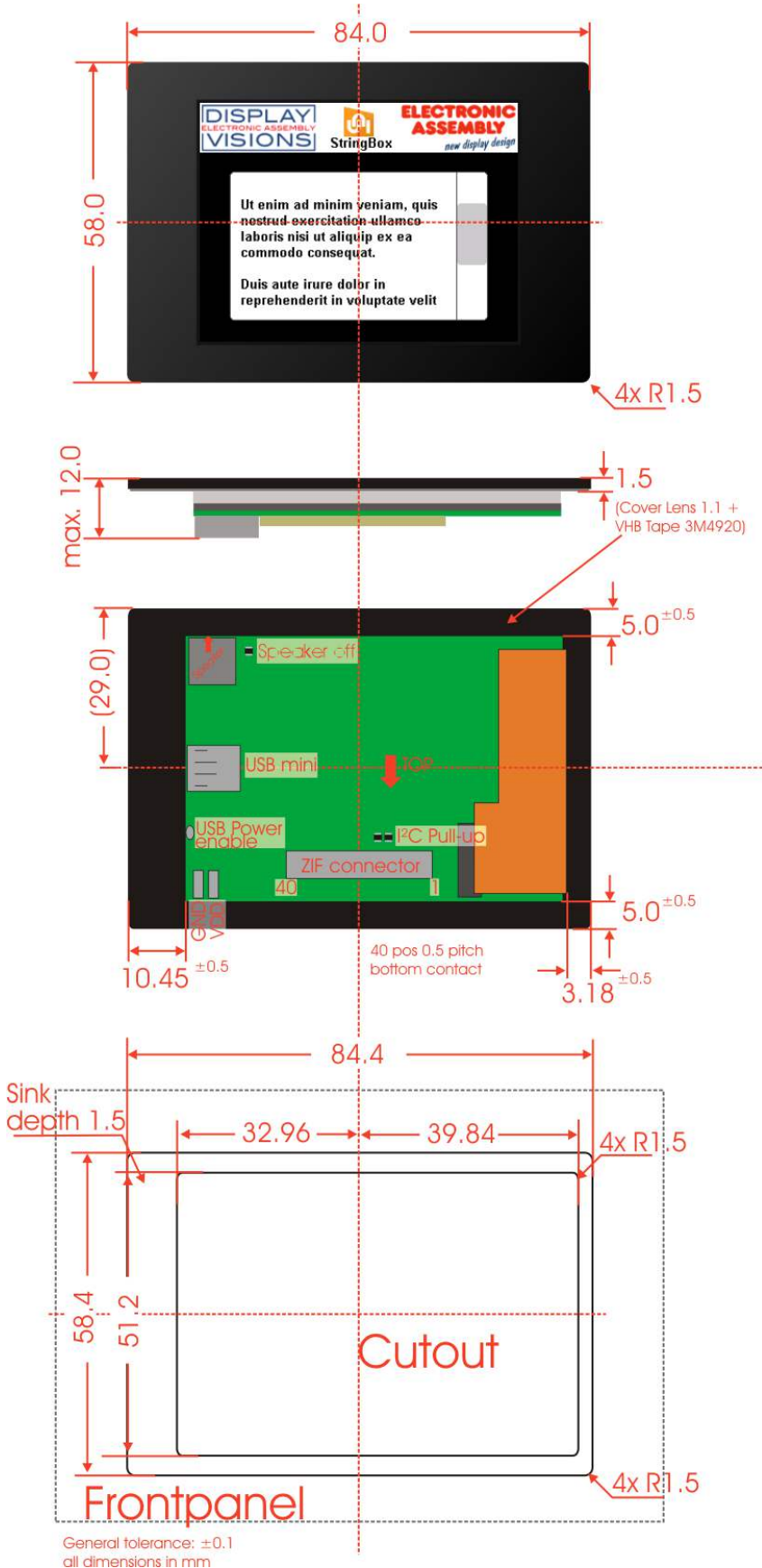

All dimension are in mm