

Note for plastic:

1. Plastic material: SABIC PC945 94-V0.
2. Color: Black.
3. Finish: texture MT 11040
4. "*" is the important dimension.
6. TOOL MARK
7. DATE CODE
8. Tolerances which are not in drawing please see tolerance table

Note for matel pin

1. Matel pin material: Brass-H62
2. Finish: nickel plating. thickness: 3~5uM

所有权信息:
本文件所有权属于 GLOBTEK 公司, 任何整体和部分的复制都是禁止和非法的, 除非取得 GLOBTEK 公司的授权允许。
PROPRIETARY INFORMATION:
PROPRIETARY OF GLOBTEK, INC. ANY REPRODUCTION, DISCLOSURE OR USE OF THIS DRAWING IN WHOLE OR PART, IS HEREBY PROHIBITED EXCEPT AS SPECIFIED IN WRITING BY GLOBTEK, INC.

REVISION			
REV	DESCRIPTION	DATE	APPROVED
A	Initial Release	2018.03.21	JET

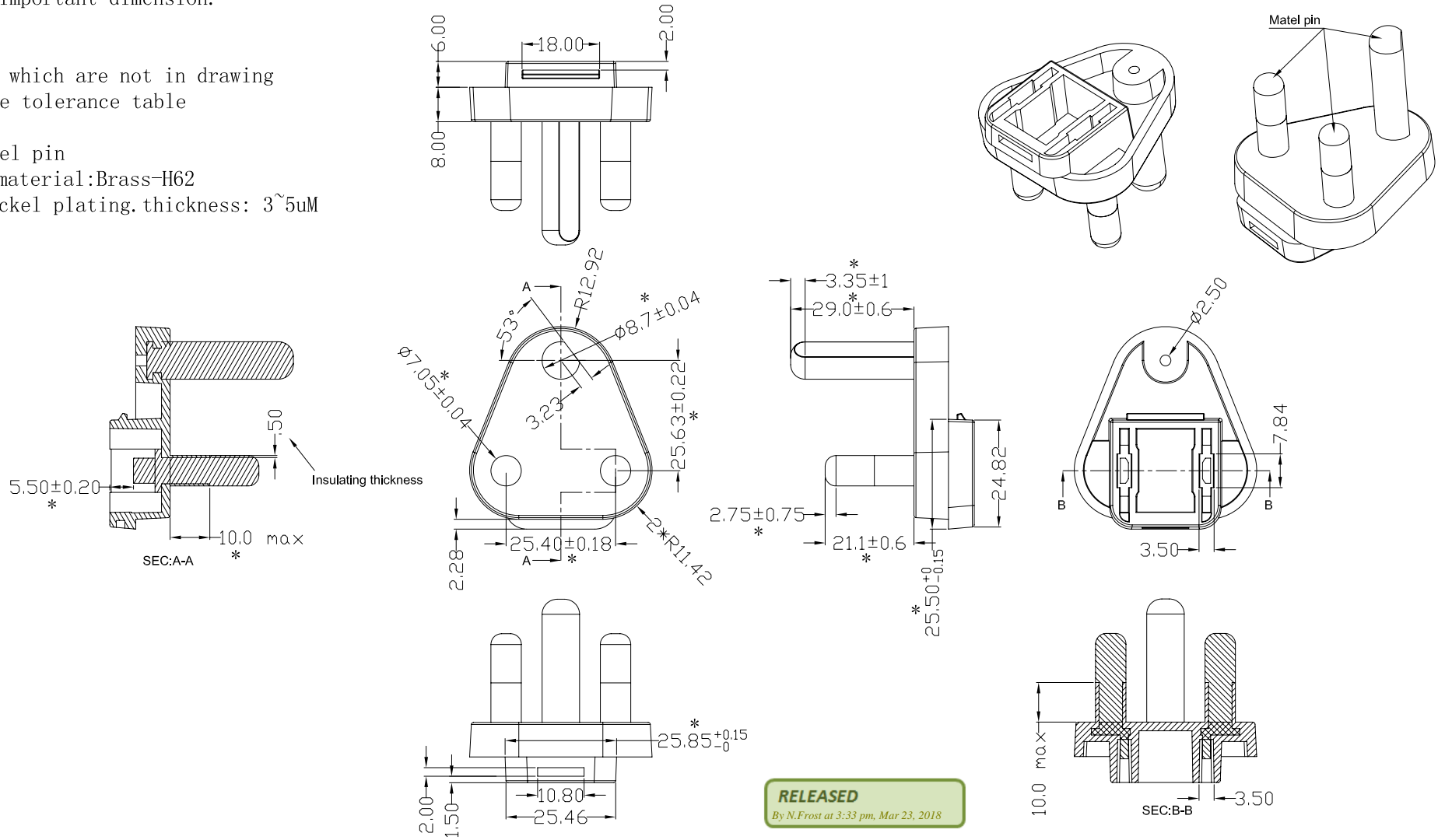

尾注:
Globtek 公司不对未经批准而擅自修改部件而影响的安全和性能负责, 终端用户必须参考 UL、CSA 或 EN 标准规定正确的安装。

Foot Note:
Globtek Inc. will not be liable for the safety and performance of these parts if unauthorized access and repair occurs. End user should consult applicable UL, CSA or EN standards for proper installation instructions

禁用:
Globtek 产品未经授权不得用于医疗设备中以及危险环境核试验或者飞机上, 除非有 GLOBTEK 公司首席执行官的书面正式批准。

Limitation of Use:
Globtek product are not authorized for use as mission critical components in life support, hazardous environment, nuclear or aircraft applications without prior written approval from the CEO of Globtek Inc.

文件内容未经允许不得更改
Contents of this document are subject to change without prior notice

Tolerance table			
RANGE	GRADE 1	GRADE 2	GRADE 3
0~4	+/-0.05	+/-0.1	+/-0.2
4~16	+/-0.08	+/-0.15	+/-0.3
16~64	+/-0.12	+/-0.25	+/-0.5
64~250	+/-0.25	+/-0.4	+/-0.8

PART NO:	450-09010304 (R)	
MODEL NO:		
Drawn and Checked By:	Jack.ji	Tolerances: Grade 2
Double Checked By:		
Approved By:	Jet	

GlobTek, Inc.
Tel: +1-201-784-1000 Fax: +1-201-784-0111 Web: www.globtek.com
GlobTek(Suzhou), Co., Ltd
Tel: +86-512-6279-0301 Fax: +86-512-6279-0355 Web: www.globtek.cn

DWG Title:
Q-SANS164-4R-16A (R)

Unit:mm A: Rev. A SHEET 1 OF 1