

AUDIOAMP 3 CLICK

PID: MIKROE-3901

Weight: 30

AudioAmp 3 Click is a stereo audio amplifier, capable of delivering up to 79W per channel with the 4Ω load. It is based on the TAS5414, a class-D integrated amplifier, which utilizes a highly efficient switching scheme. Advanced EMI Suppression with Spread Spectrum Control allows using ferrite bead filters instead of bulky inductors, still maintaining the required EMC levels. The TAS5414 IC is equipped with a set of protection features, allowing a reliable operation.

AudioAmp 3 Click is supported by a mikroSDK compliant library, which includes functions that simplify software development. This Click board™ comes as a fully tested product, ready to be used on a system equipped with the mikroBUS™ socket.

HOW DOES IT WORK?

The main component of AudioAmp 3 click is the TAS5414, Automotive stereo class-D audio amplifier, from Texas Instruments. It has many features which make this IC a very attractive solution for stand-alone active speakers. It is very flexible regarding the PSU voltage: it can work with voltages within the range from 6V to 24V. With its nominal operating voltage used at the PSU connector (14.4V) it can still deliver up to 28W of power, per channel to 4Ω load. However, in outputs can be paralleled (PBTL mode), enabling reaching over 100W of power to the connected 2Ω speaker, with low value of Total Harmonic Distortion (THD), at 24V power supply voltage.

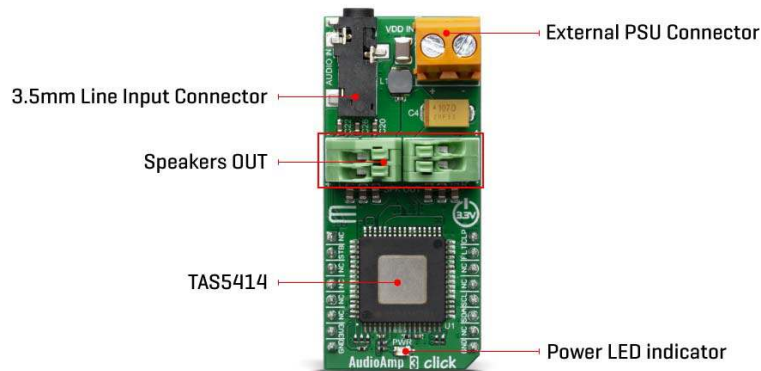

This Click board™ requires an external Power Supply Unit (PSU) for its operation. It can use a wide range of power supply voltages, from 6V up to 24V. AudioAmp 3 click a perfect solution for different kinds of active desktop speakers, battery-powered Bluetooth® and wireless speakers, TV sets and PC monitors, and other types of consumer audio equipment. Due to its high efficiency, it can even be used as a sound reinforcement solution for various IoT applications.

The device communicates with the system processor via the I2C serial communication bus as an I2C slave-only device. The processor can poll the device via I2C to determine the operating status. All fault conditions and detections are reported via I2C. There are also numerous features and operating conditions that can be set via I2C. The I2C bus allows control of the following configurations:

- Independent gain control of each channel. The gain can be set to 12 dB, 20 dB, 26 dB, and 32 dB.
- Select AM non-interference switching frequency
- Select the function of OTW_CLIP pin
- Enable or disable dc detect function with selectable threshold
- Place channel in Hi-Z (switching stopped) mode (mute)
- Select tweeter detect, set detect threshold and initiate function
- Initiate open/short load diagnostic
- Reset faults and return to normal switching operation from Hi-Z mode (unmute)

The TAS5414 IC features a set of protections, including output short circuit, over-temperature, under-voltage, over-voltage protection, and more. If any of these protections are activated, they will be reported to the main MCU at the FLT pin. The TAS5414 IC can also detect a constant DC current at the output. When a DC detection event occurs, the outputs are turned OFF, protecting the connected speakers that way.

The output stage of the TAS5414 operates in Bridge-Tied Load (BTL) topology. This means that there are two outputs per channel: one inverted and one non-inverted (OUTN and OUTP). Class-D amplifier produces the sound by modulating the pulse-width of the output voltage.

While there is no input, both OUTN and OUTP are in phase, with 50% duty cycle. There is no current through the speaker, in this case. The duty cycle will increase at the OUTP and decrease at the OUTN at the same time, when the positive half-phase of the audio signal is applied at the input. For the negative half-phase at the input, the opposite will happen. The greater the difference in pulse width, the greater the current through the connected speaker. Muting the TAS5414 before cutting down the power supply reduces pops and clicks that might appear in this case. The FLT pin is routed to the mikroBUS™ CS pin labeled as INT on this Click board™, and it is pulled to a HIGH logic level by a resistor.

The external PSU should be connected to the VIN terminal. A line-level audio source can be connected to the LINE IN 3.5mm jack stereo connector, while the speakers should be connected to the angled spring-terminals, labeled as OUTL and OUTR. These terminals have their polarities marked on the top overlay.

Although the TAS5414 IC requires an external PSU, The Click board™ can operate with 3.3V MCUs only, it is set to work over the I2C by default, and it is already equipped with the pull-up resistors. It is ready to be used as soon as it is inserted into a mikroBUS™ socket of the development system.

SPECIFICATIONS

Type	Amplifier
Applications	A perfect solution for different kinds of active desktop speakers, TV sets and PC monitors, and other types of consumer audio equipment. Due to its high efficiency, it can even be used as a sound reinforcement solution for various IoT applications.
On-board modules	TAS5414, an automotive, stereo, class-D audio amplifier, from Texas Instruments

Key Features	High efficiency, a set of protection features for reliable operation, it can be operated with the wide range of voltages, etc.
Interface	GPIO,I2C
Compatibility	mikroBUS
Click board size	L (57.15 x 25.4 mm)
Input Voltage	3.3V

PINOUT DIAGRAM

This table shows how the pinout on AudioAmp 3 Click corresponds to the pinout on the mikroBUS™ socket (the latter shown in the two middle columns).

Notes	Pin					Pin	Notes
	NC	1	AN	PWM	16	CLP	Clipping detect
Standby	STB	2	RST	INT	15	FLT	Fault
	NC	3	CS	RX	14	NC	
	NC	4	SCK	TX	13	NC	
	NC	5	MISO	SCL	12	SCL	I2C Clock
	NC	6	MOSI	SDA	11	SDA	I2C Data
Power Supply	3.3V	7	3.3V	5V	10	NC	
Ground	GND	8	GND	GND	9	GND	Ground

ONBOARD SETTINGS AND INDICATORS

Label	Name	Default	Description
PWR	PWR	-	Power LED Indicator
CN1	LINE IN	-	3.5mm stereo jack for audio input
OUTL	OUTL	-	Left speaker connector
OUTR	OUTR	-	Right speaker connector
TB1	VDD IN	-	External PSU connector

AUDIOAMP 3 ELECTRICAL CHARACTERISTICS

Description	Min	Typ	Max	Unit
External PSU Voltage	6		24	V
Minimum load Impedance	2		-	Ω
Continuous output power	-	10	-	W
Total Harmonic Distortion (THD) + noise at 1kHz; 1W; 4 Ω	-	0.02	0.1	%
Maximum Output Power at 10% THD+N; 2 Ω	-	-	150	dB

SOFTWARE SUPPORT

We provide a library for the AudioAmp 3 Click on our LibStock page, as well as a demo application (example), developed using MikroElektronika compilers. The demo can run on all the main MikroElektronika development boards.

Library Description

The library covers all the necessary functions to control AudioAmp 3 click board. A library performs a standard I2C interface communication.

Key functions:

- `AUDIOAMP3_STATUS_T audioamp3_setGainLv1(uint8_t gainLv1)` - Set the gain lv function.
- `AUDIOAMP3_STATUS_T audioamp3_setChannelMuteMode(uint8_t sChannel)` - Set the mute mode of channel function.
- `AUDIOAMP3_STATUS_T audioamp3_setPlayMode()` - Set the play mode for all channels function.

Examples description

The application is composed of three sections :

- System Initialization - Initializes I2C, GPIO and LOG structures, set INT pins as input and RST and PWM pins as output and start to write log.
- Application Initialization - Initialization driver enables - I2C, sets: power up, channel 1 & 2 to low-low state, mute all channels, run diagnostics, hardware reset, read diagnostics and play, also write log.
- Application Task - (code snippet) This is an example which demonstrates the use of AudioAmp 3 click board. Waits for valid user input and executes functions based on set of valid commands. Results are being sent to the Usart Terminal where you can track their changes.
- Commands : '+' - volume up '-' - volume down 'P' - play 'M' – mute

```
void applicationTask()
{
    char receivedData;

    if ( UART_Rdy_Ptr() )
    {
        receivedData = UART_Rd_Ptr();

        switch ( receivedData )
        {
```

```

case '+' :
{
    for( cnt = _AUDIOAMP3_MIN_GAIN; cnt < _AUDIOAMP3_GAIN_5; cnt++ )
    {
        statusFlag = audioamp3_setGainLvl( cnt );

        mikrobus_logWrite( " - Volume Up -", _LOG_LINE );
        Delay_1sec();
    }
    mikrobus_logWrite( "-----", _LOG_LINE );
    break;
}
case '-' :
{
    for( cnt = _AUDIOAMP3_MAX_GAIN; cnt > _AUDIOAMP3_GAIN_0; cnt-- )
    {
        statusFlag = audioamp3_setGainLvl( cnt );

        mikrobus_logWrite( " - Volume Down -", _LOG_LINE );
        Delay_1sec();
    }
    mikrobus_logWrite( "-----", _LOG_LINE );
    break;
}
case '=' :
{
    audioamp3_setGainLvl( _AUDIOAMP3_MEDIUM_GAIN );
    mikrobus_logWrite( " - Medium Vol. -", _LOG_LINE );
    mikrobus_logWrite( "-----", _LOG_LINE );
    break;
}
case 'M' :
{
    audioamp3_setChannelMuteMode( _AUDIOAMP3_SELECT_ALL_CHANNELS );
    mikrobus_logWrite( " Mute All Channel ", _LOG_LINE );
    mikrobus_logWrite( "-----", _LOG_LINE );
    break;
}

```

```

    }
    case 'P' :
    {
        audioamp3_setPlayMode();
        mikrobus_logWrite( "          Play          ", _LOG_LINE );
        mikrobus_logWrite( "-----", _LOG_LINE );
        break;
    }
}
}
}
}

```

The full application code, and ready to use projects can be found on our LibStock page. Other mikroE Libraries used in the example:

- I2C
- UART

Additional notes and informations

Depending on the development board you are using, you may need USB UART click, USB UART 2 click or RS232 click to connect to your PC, for development systems with no UART to USB interface available on the board. The terminal available in all MikroElektronika compilers, or any other terminal application of your choice, can be used to read the message.

MIKROSDK

This Click board™ is supported with mikroSDK - MikroElektronika Software Development Kit. To ensure proper operation of mikroSDK compliant Click board™ demo applications, mikroSDK should be downloaded from the LibStock and installed for the compiler you are using.

For more information about mikroSDK, visit the official page.