

MAX22344/MAX22345/ MAX22346

Reinforced, Fast, Low-Power, Four-Channel 3.75kV_{RMS} Digital Isolators

General Description

The MAX22344–MAX22346 are reinforced, fast, low-power 4-channel digital galvanic isolators using Maxim's proprietary process technology. These devices transfer digital signals between circuits with different power domains, using as little as 0.74mW per channel at 1Mbps (1.8V supply). All of the devices in the family feature reinforced isolation for a withstand voltage rating of 3.75kV_{RMS} for 60 seconds.

The MAX22344–MAX22346 family offers all possible unidirectional channel configurations to accommodate any 4-channel design, including SPI, RS-485, and digital I/O applications. Output enable for the A side of the MAX22345R/S is active-low, making them ideal for isolating a port on a shared SPI bus since the \overline{CS} signal can directly enable the MISO signal on the isolator. All other output enables in the MAX22344–MAX22346 family are the traditional active-high.

Devices are available with a maximum data rate of either 25Mbps or 200Mbps, and feature a selectable default state for the outputs. The default is the state the output assumes when the input is either not powered or is open-circuit. See the [Ordering Information](#) and [Product Selector Guide](#) for suffixes associated with each option. Independent 1.71V to 5.5V supplies on each side of the isolator also make the devices suitable for use as level translators.

All of the devices in the MAX22344–MAX22346 family are available in a 20-pin SSOP package with 5.5mm of creepage and clearance. All devices are rated for operation at ambient temperatures of -40°C to +125°C.

Benefits and Features

- Reinforced Galvanic Isolation for Fast Digital Signals
 - Up to 200Mbps Maximum Data Rate
 - Withstands 3.75kV_{RMS} for 60s (V_{ISO})
 - Continuously Withstands 784V_{RMS} (V_{IOWM})
 - Withstands ± 10 kV Surge between GNDA and GNDB with 1.2/50 μ s waveform
 - High CMTI (50kV/ μ s, Typical)
- Low Power Consumption
 - 0.74mW per Channel at 1Mbps with $V_{DD} = 1.8$ V
 - 1.4mW per Channel at 1Mbps with $V_{DD} = 3.3$ V
 - 3.2mW per Channel at 100Mbps with $V_{DD} = 1.8$ V
- Options to Support a Broad Range of Applications
 - 2 Maximum Data Rates (200Mbps, 25Mbps)
 - 3 Direction Configurations
 - Active-High or Active-Low Enable Inputs
 - Pin-Selectable Output Default States (High/Low)

Applications

- Isolated SPI Interface
- Fieldbus Communications for Industrial Automation
- Isolated RS-485/RS-422, CAN
- Battery Management
- Medical Systems

Safety Regulatory Approvals (Pending)

- UL According to UL1577
- cUL According to CSA Bulletin 5A
- VDE 0884-11 Reinforced Isolation

[Ordering Information](#) and [Product Selector Guide](#) appear at end of data sheet.

Absolute Maximum Ratings

V _{DDA} to GNDA.....	-0.3V to +6V	Continuous Power Dissipation (T _A = +70°C)	
V _{DDB} to GNDB.....	-0.3V to +6V	SSOP (derate 8mW/°C above +70°C).....	952.4mW
IN_ on Side A, ENA, $\overline{\text{ENA}}$, DEFA to GNDA.....	-0.3V to +6V	Operating Temperature Range.....	-40°C to +125°C
IN_ on Side B, ENB, DEFB to GNDB.....	-0.3V to +6V	Maximum Junction Temperature.....	+150°C
OUT_ on Side A to GNDA.....	-0.3V to (V _{DDA} + 0.3V)	Storage Temperature Range.....	-60°C to +150°C
OUT_ on Side B to GNDB.....	-0.3V to (V _{DDB} + 0.3V)	Lead Temperature (soldering, 10s).....	+300°C
Short Circuit Continuous Current		Soldering Temperature (reflow).....	+260°C
OUT_ on Side A to GNDA,			
OUT_ on Side B to GNDB.....	±30mA		

Stresses beyond those listed under "Absolute Maximum Ratings" may cause permanent damage to the device. These are stress ratings only; functional operation of the device at these or any other conditions beyond those indicated in the operational sections of the specifications is not implied. Exposure to absolute maximum rating conditions for extended periods may affect device reliability.

Package Information

PACKAGE TYPE: 20 SSOP	
Package Code	A20MS+7
Outline Number	21-0056
Land Pattern Number	90-0094
THERMAL RESISTANCE, FOUR-LAYER BOARD	
Junction to Ambient (θ _{JA})	84°C/W
Junction to Case (θ _{JC})	32°C/W

For the latest package outline information and land patterns (footprints), go to www.maximintegrated.com/packages. Note that a "+", "#", or "-" in the package code indicates RoHS status only. Package drawings may show a different suffix character, but the drawing pertains to the package regardless of RoHS status.

Package thermal resistances were obtained using the method described in JEDEC specification JESD51-7, using a four-layer board. For detailed information on package thermal considerations, refer to www.maximintegrated.com/thermal-tutorial.

DC Electrical Characteristics

($V_{DDA} - V_{GNDA} = 1.71V$ to $5.5V$, $V_{DDB} - V_{GNDB} = 1.71V$ to $5.5V$, $C_L = 15pF$, $T_A = -40^{\circ}C$ to $+125^{\circ}C$, unless otherwise noted. Typical values are at $V_{DDA} - V_{GNDA} = 3.3V$, $V_{DDB} - V_{GNDB} = 3.3V$, $V_{GNDA} = V_{GNDB}$, $T_A = +25^{\circ}C$, unless otherwise noted.) (Notes 1, 3)

PARAMETER	SYMBOL	CONDITIONS		MIN	TYP	MAX	UNITS
POWER SUPPLY							
Supply Voltage	V_{DDA}	Relative to GNDA		1.71		5.5	V
	V_{DDB}	Relative to GNDB		1.71		5.5	
Undervoltage-Lockout Threshold	$V_{UVLO_}$	$V_{DD_}$ rising		1.5	1.6	1.66	V
Undervoltage-Lockout Threshold Hysteresis	V_{UVLO_HYST}				45		mV
Side A Supply Current (MAX22344_) (Note 2)	I_{DDA}	500kHz square wave, $C_L = 0pF$	$V_{DDA} = 5V$		0.54	1.00	mA
			$V_{DDA} = 3.3V$		0.53	0.97	
			$V_{DDA} = 2.5V$		0.52	0.96	
			$V_{DDA} = 1.8V$		0.50	0.68	
		12.5MHz square wave, $C_L = 0pF$	$V_{DDA} = 5V$		1.67	2.50	
			$V_{DDA} = 3.3V$		1.64	2.43	
			$V_{DDA} = 2.5V$		1.62	2.41	
			$V_{DDA} = 1.8V$		1.58	2.07	
		50MHz square wave, $C_L = 0pF$	$V_{DDA} = 5V$		4.63	6.31	
			$V_{DDA} = 3.3V$		4.53	6.17	
			$V_{DDA} = 2.5V$		4.48	6.11	
			$V_{DDA} = 1.8V$		4.34	5.60	
Side B Supply Current (MAX22344_) (Note 2)	I_{DDB}	500kHz square wave, $C_L = 0pF$	$V_{DDB} = 5V$		1.19	2.06	mA
			$V_{DDB} = 3.3V$		1.17	2.02	
			$V_{DDB} = 2.5V$		1.17	2.01	
			$V_{DDB} = 1.8V$		1.14	1.92	
		12.5MHz square wave, $C_L = 0pF$	$V_{DDB} = 5V$		2.28	3.29	
			$V_{DDB} = 3.3V$		1.85	2.79	
			$V_{DDB} = 2.5V$		1.68	2.58	
			$V_{DDB} = 1.8V$		1.51	2.33	
		50MHz square wave, $C_L = 0pF$	$V_{DDB} = 5V$		5.66	7.07	
			$V_{DDB} = 3.3V$		3.98	5.16	
			$V_{DDB} = 2.5V$		3.28	4.34	
			$V_{DDB} = 1.8V$		2.69	3.59	

DC Electrical Characteristics (continued)

(V_{DDA} - V_{GNDA} = 1.71V to 5.5V, V_{DDB} - V_{GNDB} = 1.71V to 5.5V, C_L = 15pF, T_A = -40°C to +125°C, unless otherwise noted. Typical values are at V_{DDA} - V_{GNDA} = 3.3V, V_{DDB} - V_{GNDB} = 3.3V, V_{GNDA} = V_{GNDB}, T_A = +25°C, unless otherwise noted.) (Notes 1, 3)

PARAMETER	SYMBOL	CONDITIONS		MIN	TYP	MAX	UNITS
Side A Supply Current (MAX22345_) (Note 2)	I _{DDA}	500kHz square wave, C _L = 0pF	V _{DDA} = 5V		0.70	1.26	mA
			V _{DDA} = 3.3V		0.69	1.23	
			V _{DDA} = 2.5V		0.68	1.22	
			V _{DDA} = 1.8V		0.66	0.99	
		12.5MHz square wave, C _L = 0pF	V _{DDA} = 5V		1.83	2.70	
			V _{DDA} = 3.3V		1.70	2.53	
			V _{DDA} = 2.5V		1.63	2.45	
			V _{DDA} = 1.8V		1.56	2.14	
		50MHz square wave, C _L = 0pF	V _{DDA} = 5V		4.89	6.51	
			V _{DDA} = 3.3V		4.39	5.93	
			V _{DDA} = 2.5V		4.18	5.67	
			V _{DDA} = 1.8V		3.93	5.11	
Side B Supply Current (MAX22345_) (Note 2)	I _{DDB}	500kHz square wave, C _L = 0pF	V _{DDB} = 5V		1.03	1.80	mA
			V _{DDB} = 3.3V		1.01	1.76	
			V _{DDB} = 2.5V		1.01	1.75	
			V _{DDB} = 1.8V		0.98	1.61	
		12.5MHz square wave, C _L = 0pF	V _{DDB} = 5V		2.13	3.09	
			V _{DDB} = 3.3V		1.80	2.70	
			V _{DDB} = 2.5V		1.66	2.54	
			V _{DDB} = 1.8V		1.53	2.27	
		50MHz square wave, C _L = 0pF	V _{DDB} = 5V		5.41	6.88	
			V _{DDB} = 3.3V		4.11	5.41	
			V _{DDB} = 2.5V		3.58	4.78	
			V _{DDB} = 1.8V		3.11	4.11	
Side A Supply Current (MAX22346_) (Note 2)	I _{DDA}	500kHz square wave, C _L = 0pF	V _{DDA} = 5V		0.87	1.53	mA
			V _{DDA} = 3.3V		0.85	1.49	
			V _{DDA} = 2.5V		0.84	1.49	
			V _{DDA} = 1.8V		0.82	1.30	
		12.5MHz square wave, C _L = 0pF	V _{DDA} = 5V		1.98	2.89	
			V _{DDA} = 3.3V		1.75	2.61	
			V _{DDA} = 2.5V		1.65	2.49	
			V _{DDA} = 1.8V		1.55	2.20	
		50MHz square wave, C _L = 0pF	V _{DDA} = 5V		5.15	6.69	
			V _{DDA} = 3.3V		4.25	5.66	
			V _{DDA} = 2.5V		3.88	5.22	
			V _{DDA} = 1.8V		3.52	4.60	

DC Electrical Characteristics (continued)

(V_{DDA} - V_{GNDA} = 1.71V to 5.5V, V_{DDB} - V_{GNDB} = 1.71V to 5.5V, C_L = 15pF, T_A = -40°C to +125°C, unless otherwise noted. Typical values are at V_{DDA} - V_{GNDA} = 3.3V, V_{DDB} - V_{GNDB} = 3.3V, V_{GNDA} = V_{GNDB}, T_A = +25°C, unless otherwise noted.) (Notes 1, 3)

PARAMETER	SYMBOL	CONDITIONS		MIN	TYP	MAX	UNITS
Side B Supply Current (MAX22346_) (Note 2)	I _{DDB}	500kHz square wave, C _L = 0pF	V _{DDB} = 5V		0.87	1.53	mA
			V _{DDB} = 3.3V		0.85	1.49	
			V _{DDB} = 2.5V		0.84	1.49	
			V _{DDB} = 1.8V		0.82	1.30	
		12.5MHz square wave, C _L = 0pF	V _{DDB} = 5V		1.98	2.89	
			V _{DDB} = 3.3V		1.75	2.61	
			V _{DDB} = 2.5V		1.65	2.49	
			V _{DDB} = 1.8V		1.55	2.20	
		50MHz square wave, C _L = 0pF	V _{DDB} = 5V		5.15	6.69	
			V _{DDB} = 3.3V		4.25	5.66	
			V _{DDB} = 2.5V		3.88	5.22	
			V _{DDB} = 1.8V		3.52	4.60	
LOGIC INTERFACE (IN_, EN_, $\overline{\text{ENA}}$, DEF_, OUT_)							
Input High Voltage	V _{IH}	EN_, $\overline{\text{ENA}}$, IN_	2.25V ≤ V _{DD_} ≤ 5.5V		0.7 x	V _{DD_}	V
			1.71V ≤ V _{DD_} < 2.25V		0.75 x	V _{DD_}	
		DEF_ (Note 2)	2.25V ≤ V _{DD_} ≤ 5.5V		0.7 x	V _{DD_}	
			1.71V ≤ V _{DD_} < 2.25V		0.75 x	V _{DD_}	

DC Electrical Characteristics (continued)

(V_{DDA} - V_{GNDA} = 1.71V to 5.5V, V_{DDB} - V_{GNDB} = 1.71V to 5.5V, C_L = 15pF, T_A = -40°C to +125°C, unless otherwise noted. Typical values are at V_{DDA} - V_{GNDA} = 3.3V, V_{DDB} - V_{GNDB} = 3.3V, V_{GNDA} = V_{GNDB}, T_A = +25°C, unless otherwise noted.) (Notes 1, 3)

PARAMETER	SYMBOL	CONDITIONS	MIN	TYP	MAX	UNITS
Input Low Voltage	V _{IL}	EN_, $\overline{\text{ENA}}$, IN_	2.25V ≤ V _{DD_} ≤ 5.5V		0.8	V
			1.71V ≤ V _{DD_} < 2.25V		0.7	
		DEF_ (Note 2)	2.25V ≤ V _{DD_} ≤ 5.5V		0.8	
			1.71V ≤ V _{DD_} < 2.25V		0.7	
Input Hysteresis	V _{HYS}	EN_, $\overline{\text{ENA}}$, DEF_, IN_	MAX2234_B/R	410		mV
			MAX2234_C/S	80		
IN_ Input Pullup Current	I _{PU}	DEFA = DEFB = high	-10	-5	-1.5	μA
IN_ Input Pulldown Current	I _{PD}	DEFA = DEFB = low	1.5	5	10	μA
IN_ Input Capacitance	C _{IN}	f _{SW} = 1MHz		2		pF
ENA Pullup Current	I _{PU_ENA}	MAX2234_B/C	-10	-5	-1.5	μA
ENB Pullup Current	I _{PU_ENB}		-10	-5	-1.5	μA
$\overline{\text{ENA}}$ Pulldown Current	I _{PD_EN}	MAX22345R/S	1.5	5	10	μA
DEF_ Pullup Current	I _{PU_DEF}		-10	-5	-1.5	μA
OUT_ Output Voltage High	V _{OH}	I _{OUT_} = -4mA source		V _{DD_} - 0.4		V
OUT_ Output Voltage Low	V _{OL}	I _{OUT_} = 4mA sink			0.4	V

Dynamic Characteristics MAX2234_C/S

(V_{DDA} - V_{GND A} = 1.71V to 5.5V, V_{DDB} - V_{GND B} = 1.71V to 5.5V, C_L = 15pF, T_A = -40°C to +125°C, unless otherwise noted. Typical values are at V_{DDA} - V_{GND A} = 3.3V, V_{DDB} - V_{GND B} = 3.3V, V_{GND A} = V_{GND B}, T_A = +25°C, unless otherwise noted.) (Notes 2, 4)

PARAMETER	SYMBOL	CONDITIONS		MIN	TYP	MAX	UNITS
Common-Mode Transient Immunity	CMTI	IN ₋ = GND ₋ or V _{DD-} (Note 5)		50			kV/μs
Maximum Data Rate	DR _{MAX}	2.25V ≤ V _{DD-} ≤ 5.5V		200			Mbps
		1.71V ≤ V _{DD-} < 2.25V		150			
Minimum Pulse Width	PW _{MIN}	IN ₋ to OUT ₋	2.25V ≤ V _{DD-} ≤ 5.5V	5.00			ns
			1.71V ≤ V _{DD-} < 2.25V	6.67			
Propagation Delay (Figure 3)	t _{PLH}	IN ₋ to OUT ₋ , C _L = 15pF	4.5V ≤ V _{DD-} ≤ 5.5V	4.1	5.7	9.2	ns
			3.0V ≤ V _{DD-} ≤ 3.6V	4.2	6.5	10.2	
			2.25V ≤ V _{DD-} ≤ 2.75V	4.9	7.9	13.4	
			1.71V ≤ V _{DD-} ≤ 1.89V	7.1	12.0	20.3	
	t _{PHL}	IN ₋ to OUT ₋ , C _L = 15pF	4.5V ≤ V _{DD-} ≤ 5.5V	4.3	6.1	9.4	
			3.0V ≤ V _{DD-} ≤ 3.6V	4.4	6.9	10.5	
			2.25V ≤ V _{DD-} ≤ 2.75V	5.1	8.2	14.1	
			1.71V ≤ V _{DD-} ≤ 1.89V	7.2	12.1	21.7	
Pulse Width Distortion	PWD	t _{PLH} - t _{PHL}	4.5V ≤ V _{DD-} ≤ 5.5V	0.4		2.0	ns
			3.0V ≤ V _{DD-} ≤ 3.6V	0.4		2.0	
			2.25V ≤ V _{DD-} ≤ 2.75V	0.3		2.0	
			1.71V ≤ V _{DD-} ≤ 1.89V	0.0		2.0	
Propagation Delay Skew Part-to-Part (Same Channel)	t _{SPLH}	4.5V ≤ V _{DD-} ≤ 5.5V		3.7			ns
		3.0V ≤ V _{DD-} ≤ 3.6V		4.3			
		2.25V ≤ V _{DD-} ≤ 2.75V		6.0			
		1.71V ≤ V _{DD-} ≤ 1.89V		10.3			
	t _{SPHL}	4.5V ≤ V _{DD-} ≤ 5.5V		3.8			
		3.0V ≤ V _{DD-} ≤ 3.6V		4.7			
		2.25V ≤ V _{DD-} ≤ 2.75V		6.5			
		1.71V ≤ V _{DD-} ≤ 1.89V		11.5			
Propagation Delay Skew Channel-to-Channel (Same Direction)	t _{SCSLH}	1.71V ≤ V _{DD-} ≤ 5.5V		2.0			ns
	t _{SCSHL}	1.71V ≤ V _{DD-} ≤ 5.5V		2.0			

Dynamic Characteristics MAX2234_C/S (continued)

(V_{DDA} - V_{GNDA} = 1.71V to 5.5V, V_{DDB} - V_{GNDB} = 1.71V to 5.5V, C_L = 15pF, T_A = -40°C to +125°C, unless otherwise noted. Typical values are at V_{DDA} - V_{GNDA} = 3.3V, V_{DDB} - V_{GNDB} = 3.3V, V_{GNDA} = V_{GNDB}, T_A = +25°C, unless otherwise noted.) (Notes 2, 4)

PARAMETER	SYMBOL	CONDITIONS		MIN	TYP	MAX	UNITS
Propagation Delay Skew Channel-to-Channel (Opposite Direction)	t _{SCOLH}	4.5V ≤ V _{DD_} ≤ 5.5V				2.9	ns
		3.0V ≤ V _{DD_} ≤ 3.6V				3.4	
		2.25V ≤ V _{DD_} ≤ 2.75V				4.9	
		1.71V ≤ V _{DD_} ≤ 1.89V				10.2	
	t _{SCOHL}	4.5V ≤ V _{DD_} ≤ 5.5V				3.2	
		3.0V ≤ V _{DD_} ≤ 3.6V				3.8	
		2.25V ≤ V _{DD_} ≤ 2.75V				5.3	
		1.71V ≤ V _{DD_} ≤ 1.89V				10.9	
Peak Eye Diagram Jitter	T _{JIT(PK)}	200Mbps			100		ps
Clock Jitter RMS	T _{JCLK(RMS)}	500kHz clock input, rising/falling edges			7.5		ps
Rise Time (Figure 3)	t _R	C _L = 5pF	4.5V ≤ V _{DD_} ≤ 5.5V			0.8	ns
			3.0V ≤ V _{DD_} ≤ 3.6V			1.1	
			2.25V ≤ V _{DD_} ≤ 2.75V			1.5	
			1.71V ≤ V _{DD_} ≤ 1.89V			2.4	
Fall Time (Figure 3)	t _F	C _L = 5pF	4.5V ≤ V _{DD_} ≤ 5.5V			1.0	ns
			3.0V ≤ V _{DD_} ≤ 3.6V			1.4	
			2.25V ≤ V _{DD_} ≤ 2.75V			1.9	
			1.71V ≤ V _{DD_} ≤ 1.89V			3.0	
Enable to Data Valid (Figure 4)	t _{EN}	EN _A to OUT _A , EN _B to OUT _B , C _L = 15pF	4.5V ≤ V _{DD_} ≤ 5.5V			3.9	ns
			3.0V ≤ V _{DD_} ≤ 3.6V			6.4	
			2.25V ≤ V _{DD_} ≤ 2.75V			10.1	
			1.71V ≤ V _{DD_} ≤ 1.89V			18.4	
Enable to Tristate (Figure 4)	t _{TRI}	EN _A to OUT _A , EN _B to OUT _B , C _L = 15pF	4.5V ≤ V _{DD_} ≤ 5.5V			6.3	ns
			3.0V ≤ V _{DD_} ≤ 3.6V			9.0	
			2.25V ≤ V _{DD_} ≤ 2.75V			12.6	
			1.71V ≤ V _{DD_} ≤ 1.89V			19.2	

Dynamic Characteristics MAX2234_B/R

(V_{DDA} - V_{GNDA} = 1.71V to 5.5V, V_{DDB} - V_{GNDB} = 1.71V to 5.5V, C_L = 15pF, T_A = -40°C to +125°C, unless otherwise noted. Typical values are at V_{DDA} - V_{GNDA} = 3.3V, V_{DDB} - V_{GNDB} = 3.3V, V_{GNDA} = V_{GNDB}, T_A = +25°C, unless otherwise noted.) (Notes 2, 4)

PARAMETER	SYMBOL	CONDITIONS	MIN	TYP	MAX	UNITS	
Common-Mode Transient Immunity	CMTI	IN_ = GND_ or VDD_ (Note 5)		50		kV/μs	
Maximum Data Rate	DR _{MAX}		25			Mbps	
Minimum Pulse Width	PW _{MIN}	IN_ to OUT_			40	ns	
Glitch Rejection		IN_ to OUT_	10	17	29	ns	
Propagation Delay (Figure 3)	t _{PLH}	IN_ to OUT_, C _L = 15pF	4.5V ≤ V _{DD_} ≤ 5.5V	17.4	24.2	32.5	ns
			3.0V ≤ V _{DD_} ≤ 3.6V	17.6	25.0	33.7	
			2.25V ≤ V _{DD_} ≤ 2.75V	18.3	26.4	36.7	
			1.71V ≤ V _{DD_} ≤ 1.89V	20.7	30.6	43.5	
	t _{PHL}	IN_ to OUT_, C _L = 15pF	4.5V ≤ V _{DD_} ≤ 5.5V	16.9	24.0	33.6	
			3.0V ≤ V _{DD_} ≤ 3.6V	17.2	24.8	35.1	
			2.25V ≤ V _{DD_} ≤ 2.75V	17.8	26.1	38.2	
			1.71V ≤ V _{DD_} ≤ 1.89V	19.8	30.0	45.8	
Pulse Width Distortion	PWD	t _{PLH} - t _{PHL}	4.5V ≤ V _{DD_} ≤ 5.5V		0.2	4.0	ns
			3.0V ≤ V _{DD_} ≤ 3.6V		0.2	4.0	
			2.25V ≤ V _{DD_} ≤ 2.75V		0.3	4.0	
			1.71V ≤ V _{DD_} ≤ 1.89V		0.6	4.0	
Propagation Delay Skew Part-to-Part (Same Channel)	t _{SPLH}		4.5V ≤ V _{DD_} ≤ 5.5V			15.1	ns
			3.0V ≤ V _{DD_} ≤ 3.6V			15.0	
			2.25V ≤ V _{DD_} ≤ 2.75V			15.4	
			1.71V ≤ V _{DD_} ≤ 1.89V			20.5	
	t _{SPHL}		4.5V ≤ V _{DD_} ≤ 5.5V			13.9	
			3.0V ≤ V _{DD_} ≤ 3.6V			14.2	
			2.25V ≤ V _{DD_} ≤ 2.75V			16.0	
			1.71V ≤ V _{DD_} ≤ 1.89V			21.8	
Propagation Delay Skew Channel-to-Channel (Same Direction)	t _{SCSLH}	1.71V ≤ V _{DD_} ≤ 5.5V			2.0	ns	
	t _{SCSHL}	1.71V ≤ V _{DD_} ≤ 5.5V			2.0		
Propagation Delay Skew Channel-to-Channel (Opposite Direction)	t _{SCOLH}		4.5V ≤ V _{DD_} ≤ 5.5V			13.9	ns
			3.0V ≤ V _{DD_} ≤ 3.6V			13.7	
			2.25V ≤ V _{DD_} ≤ 2.75V			14.2	
			1.71V ≤ V _{DD_} ≤ 1.89V			19.4	
	t _{SCOHL}		4.5V ≤ V _{DD_} ≤ 5.5V			13.0	
			3.0V ≤ V _{DD_} ≤ 3.6V			12.9	
			2.25V ≤ V _{DD_} ≤ 2.75V			14.4	
			1.71V ≤ V _{DD_} ≤ 1.89V			20.1	

Dynamic Characteristics MAX2234_B/R (continued)

($V_{DDA} - V_{GNDA} = 1.71V$ to $5.5V$, $V_{DDB} - V_{GNDB} = 1.71V$ to $5.5V$, $C_L = 15pF$, $T_A = -40^{\circ}C$ to $+125^{\circ}C$, unless otherwise noted. Typical values are at $V_{DDA} - V_{GNDA} = 3.3V$, $V_{DDB} - V_{GNDB} = 3.3V$, $V_{GNDA} = V_{GNDB}$, $T_A = +25^{\circ}C$, unless otherwise noted.) (Notes 2, 4)

PARAMETER	SYMBOL	CONDITIONS		MIN	TYP	MAX	UNITS
Peak Eye Diagram Jitter	$T_{JIT(PK)}$	25Mbps			250		ps
Rise Time (Figure 3)	t_R	$C_L = 5pF$	$4.5V \leq V_{DD_} \leq 5.5V$			0.8	ns
			$3.0V \leq V_{DD_} \leq 3.6V$			1.1	
			$2.25V \leq V_{DD_} \leq 2.75V$			1.5	
			$1.71V \leq V_{DD_} \leq 1.89V$			2.4	
Fall Time (Figure 3)	t_F	$C_L = 5pF$	$4.5V \leq V_{DD_} \leq 5.5V$			1.0	ns
			$3.0V \leq V_{DD_} \leq 3.6V$			1.4	
			$2.25V \leq V_{DD_} \leq 2.75V$			1.9	
			$1.71V \leq V_{DD_} \leq 1.89V$			3.0	
Enable to Data Valid (Figure 4)	t_{EN}	\overline{ENA} to OUT ₋ , EN ₋ to OUT ₋ , $C_L = 15pF$	$4.5V \leq V_{DD_} \leq 5.5V$			3.9	ns
			$3.0V \leq V_{DD_} \leq 3.6V$			6.4	
			$2.25V \leq V_{DD_} \leq 2.75V$			10.1	
			$1.71V \leq V_{DD_} \leq 1.89V$			18.4	
Enable to Tristate (Figure 4)	t_{TRI}	\overline{ENA} to OUT ₋ , EN ₋ to OUT ₋ , $C_L = 15pF$	$4.5V \leq V_{DD_} \leq 5.5V$			6.3	ns
			$3.0V \leq V_{DD_} \leq 3.6V$			9.0	
			$2.25V \leq V_{DD_} \leq 2.75V$			12.6	
			$1.71V \leq V_{DD_} \leq 1.89V$			19.2	

Note 1: All devices are 100% production tested at $T_A = +125^{\circ}C$. Specifications over temperature are guaranteed by design and characterization.

Note 2: Not production tested. Guaranteed by design and characterization.

Note 3: All currents into the device are positive. All currents out of the device are negative. All voltages are referenced to their respective ground (GNDA or GNDB), unless otherwise noted.

Note 4: All measurements taken with $V_{DDA} = V_{DDB}$, unless otherwise noted.

Note 5: CMTI is the maximum sustainable common-mode voltage slew rate while maintaining the correct output. CMTI applies to both rising and falling common-mode voltage edges. Tested with the transient generator connected between GNDA and GNDB ($V_{CM} = 1000V$).

ESD Protection

PARAMETER	SYMBOL	CONDITIONS	MIN	TYP	MAX	UNITS
ESD		Human Body Model, All Pins		±4		kV

Table 1. Insulation Characteristics

PARAMETER	SYMBOL	CONDITIONS	VALUE	UNITS
Partial Discharge Test Voltage	V _{PR}	Method B1 = V _{IORM} × 1.875 (t = 1s, partial discharge < 5pC)	2078	V _P
Maximum Repetitive Peak Isolation Voltage	V _{IORM}	(Note 6)	1108	V _P
Maximum Working Isolation Voltage	V _{IOWM}	Continuous RMS voltage (Note 6)	784	V _{RMS}
Maximum Transient Isolation Voltage	V _{IOTM}	t = 1s	5300	V _P
Maximum Withstand Isolation Voltage	V _{ISO}	f _{SW} = 60Hz, duration = 60s (Note 7)	3750	V _{RMS}
Maximum Surge Isolation Voltage	V _{IOSM}	Basic Insulation, 1.2/50µs pulse per IEC61000-4-5	10	kV
Insulation Resistance	R _{IO}	V _{IO} = 500V, T _A = 25°C	>10 ¹²	Ω
		V _{IO} = 500V, 100°C ≤ T _A ≤ 125°C	>10 ¹¹	
		V _{IO} = 500V at T _S = 150°C	>10 ⁹	
Barrier Capacitance Side A to Side B	C _{IO}	f _{SW} = 1MHz (Note 8)	1.5	pF
Minimum Creepage Distance	CPG		5.5	mm
Minimum Clearance Distance	CLR		5.5	mm
Internal Clearance		Distance through insulation	0.021	mm
Comparative Tracking Index	CTI	Material Group II (IEC 60112)	>400	
Climate Category			40/125/21	
Pollution Degree (DIN VDE 0110, Table 1)			2	

Note 6: V_{ISO}, V_{IOWM}, and V_{IORM} are defined by the IEC 60747-5-5 standard.

Note 7: Product is qualified at V_{ISO} for 60s and 100% production tested at 120% of V_{ISO} for 1s.

Note 8: Capacitance is measured with all pins on field-side and logic-side tied together.

Safety Limits

Damage to the IC can result in a low-resistance path to ground or to the supply and, without current limiting, the MAX22344–MAX22346 could dissipate excessive amounts of power. Excessive power dissipation can damage the die and result in damage to the isolation barrier, potentially causing downstream issues. [Table 2](#) shows the safety limits for the MAX22344–MAX22346.

The maximum safety temperature (T_S) for the device is the 150°C maximum junction temperature specified in the Absolute Maximum Ratings. The power dissipation (P_D) and junction-to-ambient thermal impedance (θ_{JA}) deter-

mine the junction temperature. Thermal impedance values (θ_{JA} and θ_{JC}) are available in the Package Thermal Characteristics section of the datasheet and power dissipation calculations are discussed in the Calculating Power Dissipation section. Calculate the junction temperature (T_J) as:

$$T_J = T_A + (P_D \times \theta_{JA})$$

[Figure 1](#) and [Figure 2](#) show the thermal derating curve for safety limiting the power and the current of the device. Ensure that the junction temperature does not exceed 150°C.

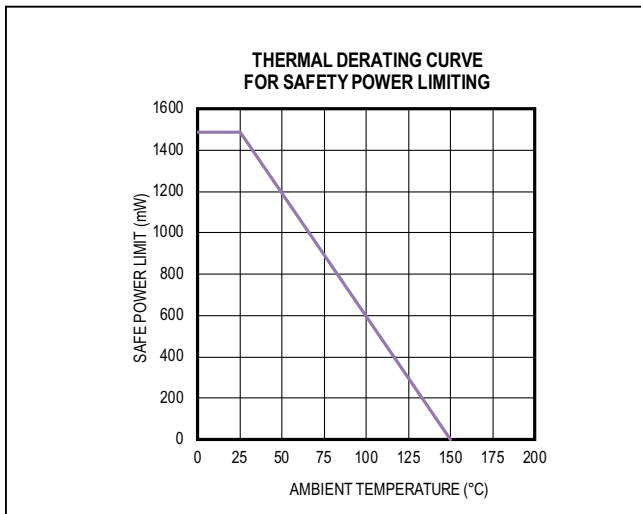

Figure 1. Thermal Derating Curve for Safety Power Limiting

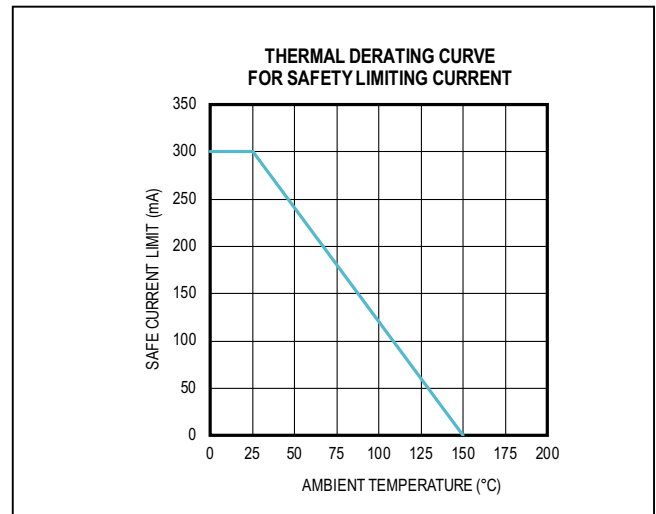

Figure 2. Thermal Derating Curve for Safety Current Limiting

Table 2. Safety Limiting Values for the MAX22344–MAX22346

PARAMETER	SYMBOL	TEST CONDITIONS	MAX	UNIT
Safety Current on Any Pin	I_S	$T_J = 150^\circ\text{C}$, $T_A = 25^\circ\text{C}$	300	mA
Total Safety Power Dissipation	P_S	$T_J = 150^\circ\text{C}$, $T_A = 25^\circ\text{C}$	1448	mW
Maximum Safety Temperature	T_S		150	°C

Test Circuits and Timing Diagrams

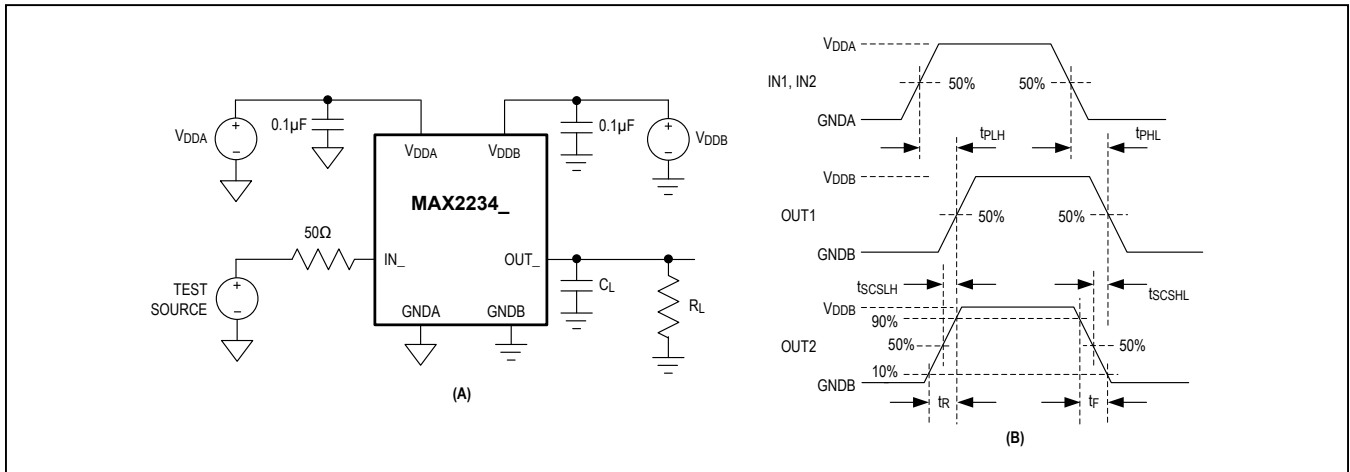

Figure 3. Test Circuit (A) and Timing Diagram (B)

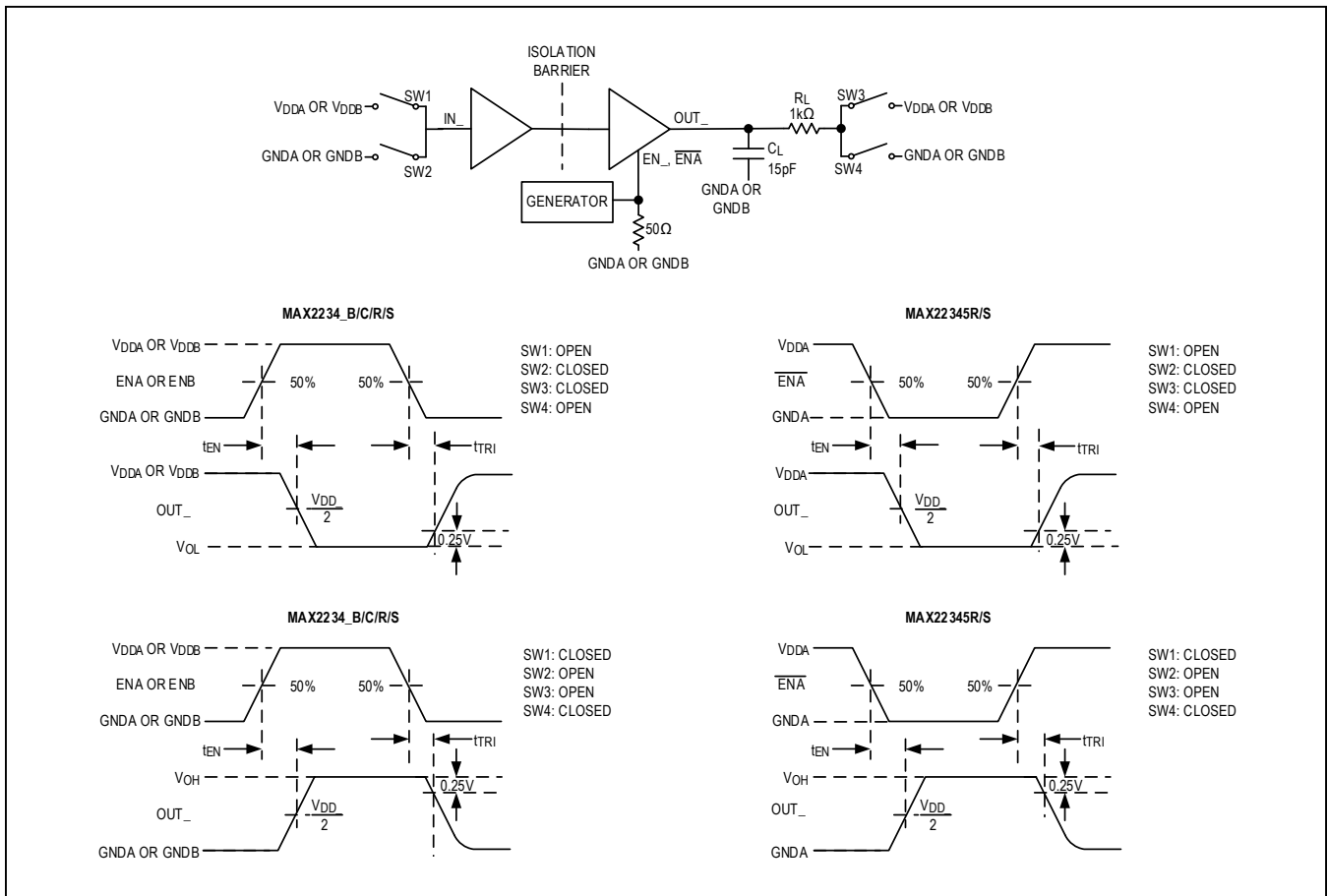
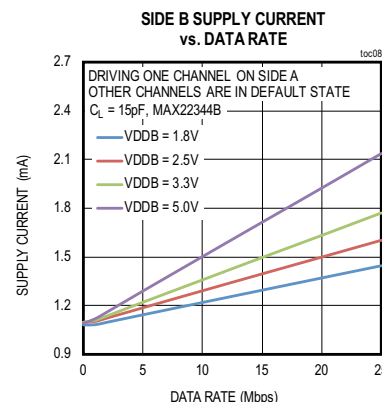
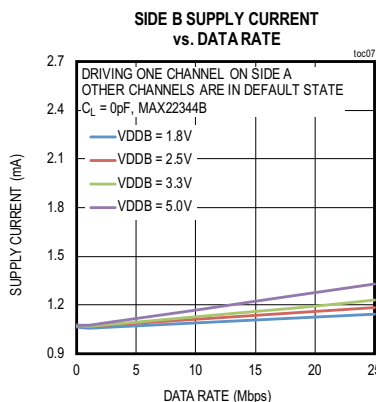
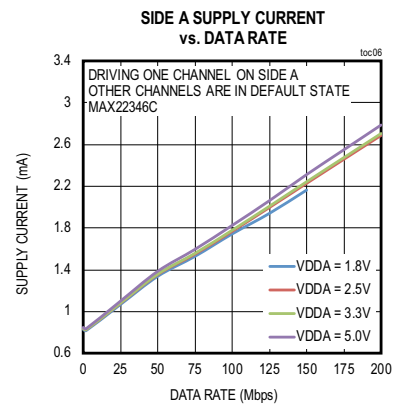
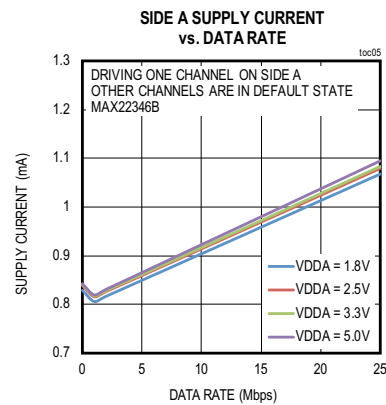
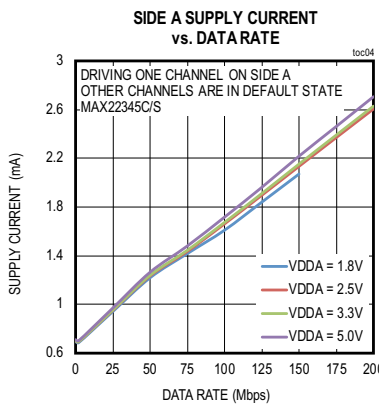
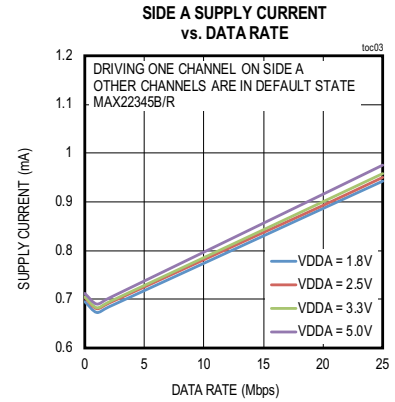
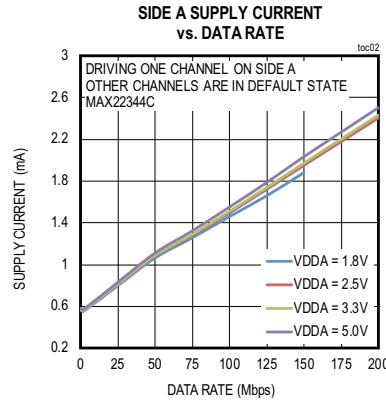
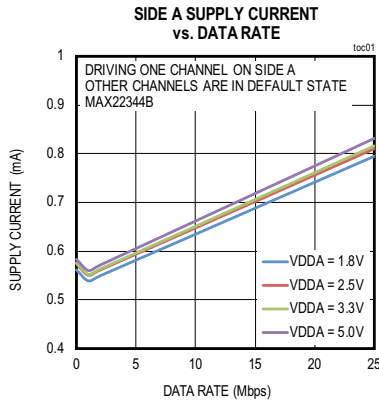

Figure 4. Enable to Output Timing (t_{EN}, t_{TRI})

Typical Operating Characteristics

(V_{DDA} - V_{GND A} = +3.3V, V_{DDB} - V_{GND B} = +3.3V, V_{GND A} = V_{GND B}, T_A = +25°C, unless otherwise noted.)



Typical Operating Characteristics (continued)

(V_{DDA} - V_{GND A} = +3.3V, V_{DDB} - V_{GND B} = +3.3V, V_{GND A} = V_{GND B}, T_A = +25°C, unless otherwise noted.)

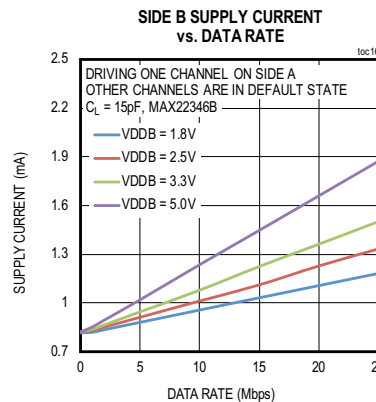
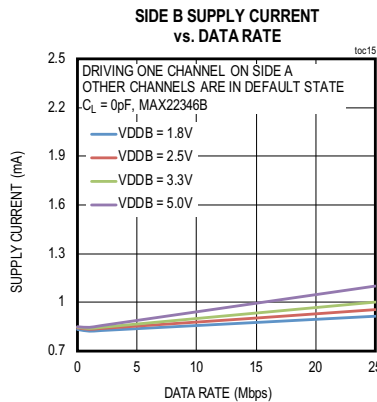
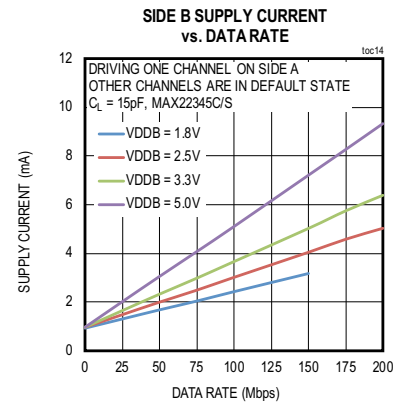
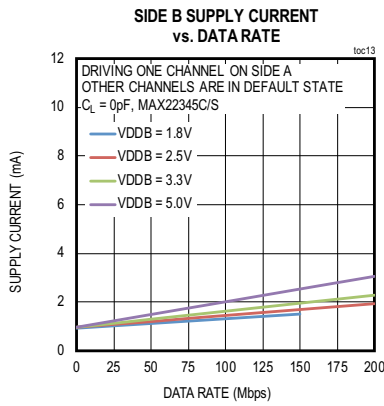
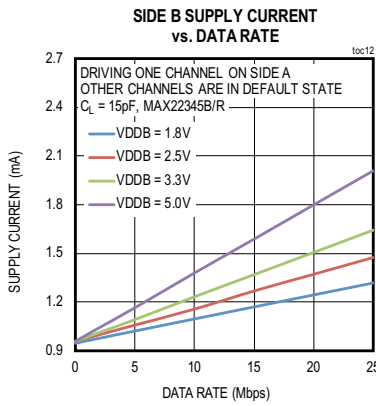
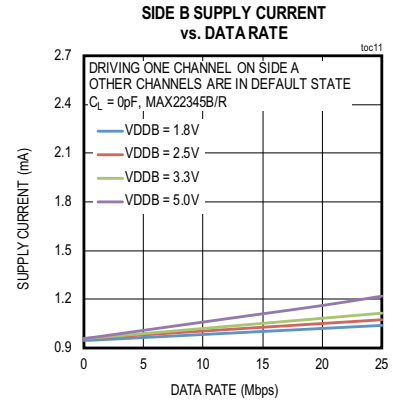
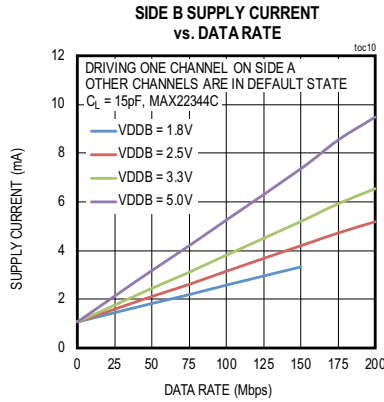
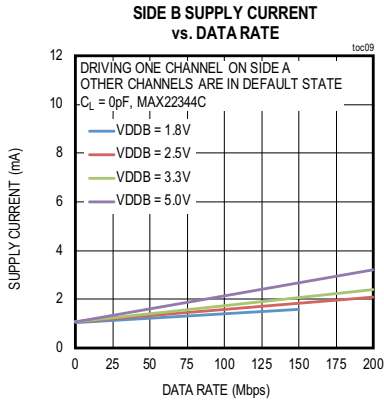

Typical Operating Characteristics (continued)

(V_{DDA} - V_{GNDA} = +3.3V, V_{DDB} - V_{GNDB} = +3.3V, V_{GNDA} = V_{GNDB}, T_A = +25°C, unless otherwise noted.)

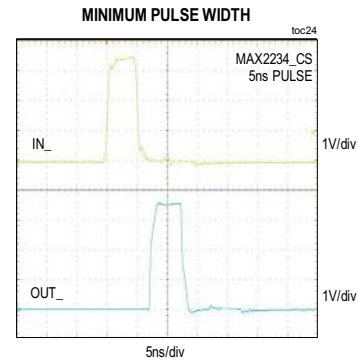
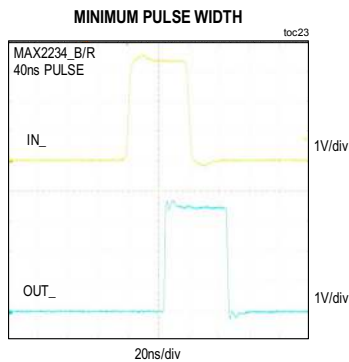
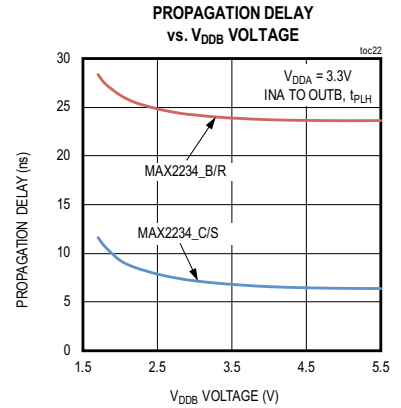
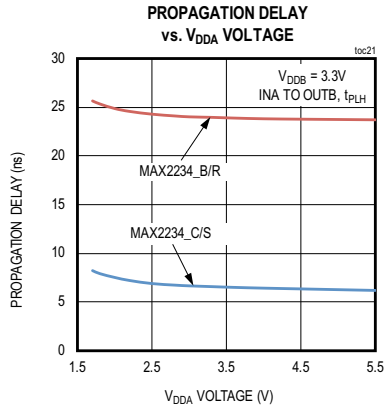
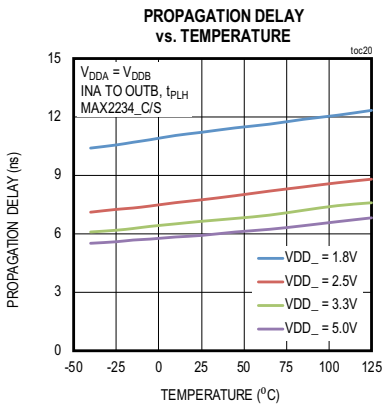
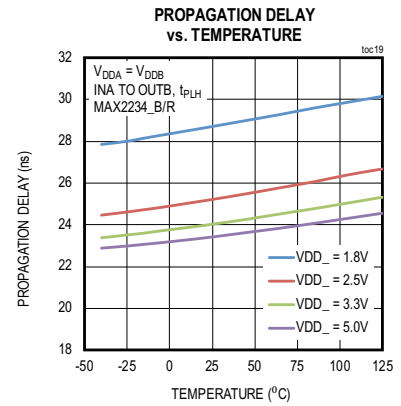
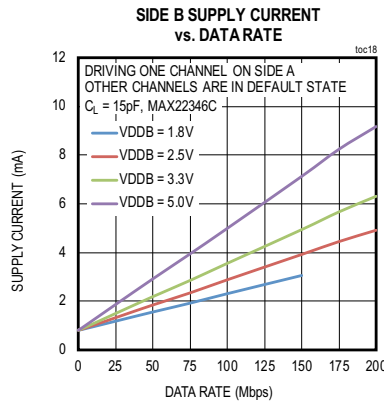
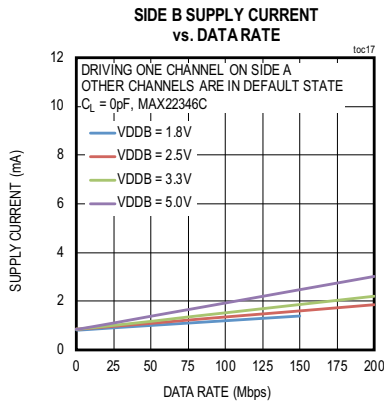

Typical Operating Characteristics (continued)

(V_{DDA} - V_{GNDA} = +3.3V, V_{DDB} - V_{GNDB} = +3.3V, V_{GNDA} = V_{GNDB}, T_A = +25°C, unless otherwise noted.)

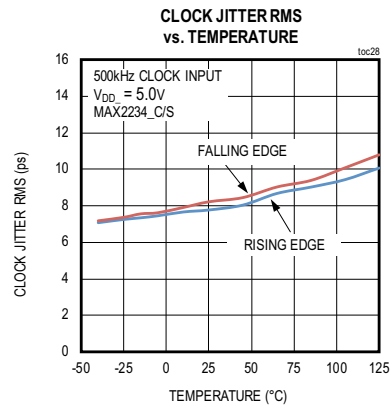
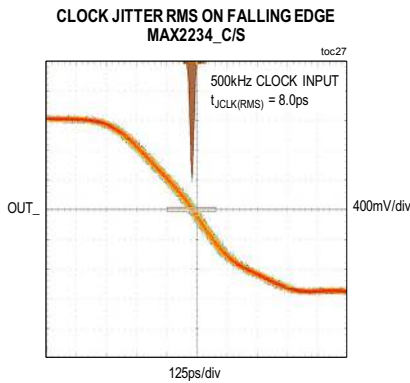
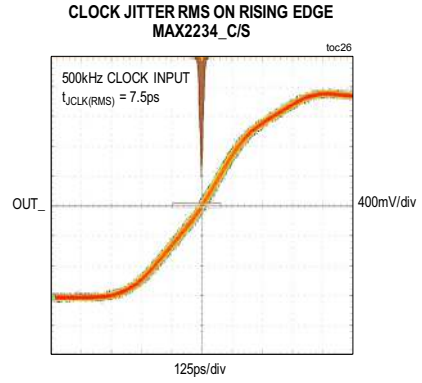
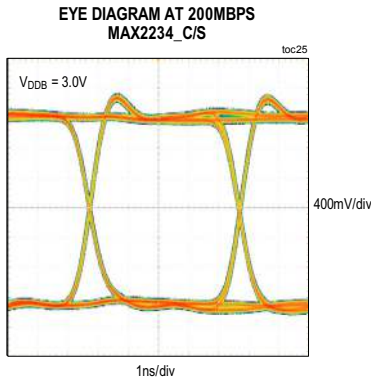

Pin Configurations

TOP VIEW

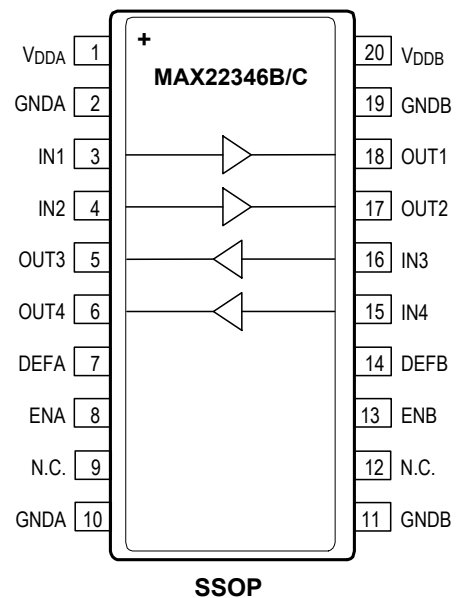
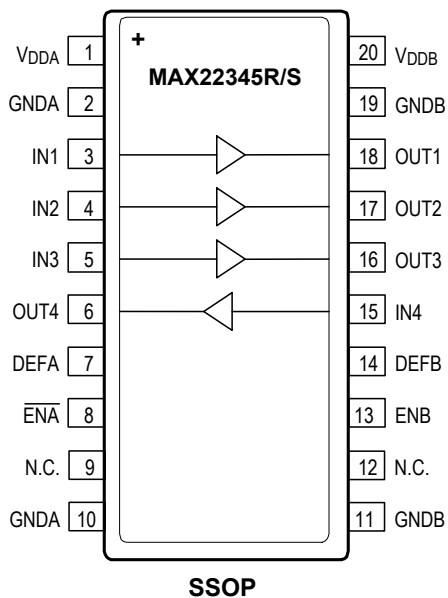
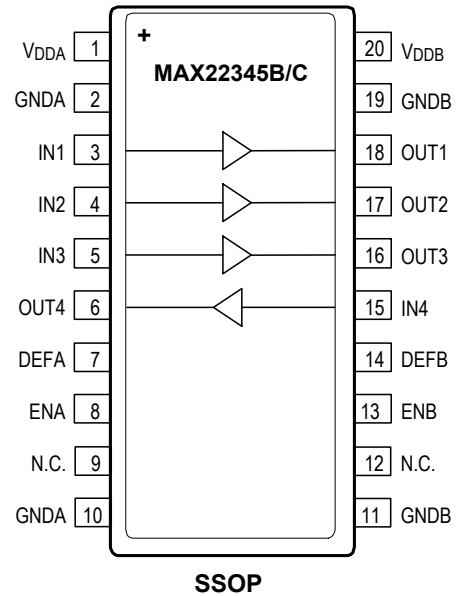
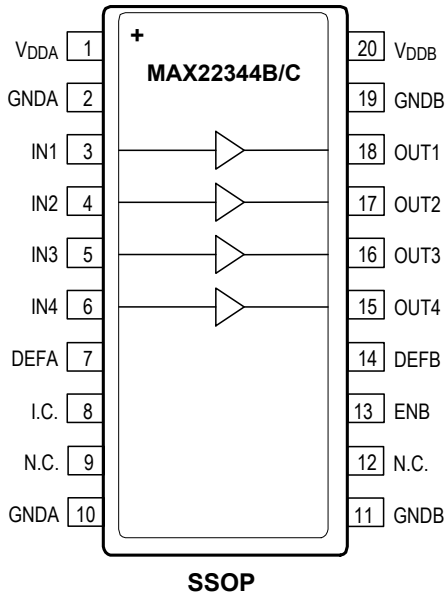

Pin Description

NAME	PIN			
	MAX22344B/C	MAX22345B/C	MAX22345R/S	MAX22346B/C
V _{DDA}	1	1	1	1
G _{NDA}	2, 10	2, 10	2, 10	2, 10
IN1	3	3	3	3
IN2	4	4	4	4
IN3	5	5	5	16
IN4	6	15	15	15
DEFA	7	7	7	7
I.C.	8	—	—	—
N.C.	9, 12	9, 12	9, 12	9, 12
ENA	—	8	—	8
$\overline{\text{ENA}}$	—	—	8	—
G _{NDB}	11, 19	11, 19	11, 19	11, 19
ENB	13	13	13	13
DEFB	14	14	14	14
OUT4	15	6	6	6
OUT3	16	16	16	5
OUT2	17	17	17	17
OUT1	18	18	18	18
V _{ddb}	20	20	20	20

Pin Description (continued)

NAME	FUNCTION
POWER	
V _{DDA}	Power Supply Input for Side A. Bypass V _{DDA} to GNDA with a 0.1μF ceramic capacitor as close as possible to the pin.
GNDA	Ground Reference for Side A.
V _{ddb}	Power Supply Input for Side B. Bypass V _{ddb} to GNDB with a 0.1μF ceramic capacitor as close as possible to the pin.
GNDB	Ground reference for Side B.
INPUTS	
IN1	Logic Input 1 on Side A. Corresponds to Logic Output 1 on Side B.
IN2	Logic Input 2 on Side A. Corresponds to Logic Output 2 on Side B.
IN3	Logic Input 3 on Side A/B. Corresponds to Logic Output 3 on Side B/A.
IN4	Logic Input 4 on Side A/B. Corresponds to Logic Output 4 on Side B/A.
OUTPUTS	
OUT1	Logic Output 1 on Side B. OUT1 is the logic output for the IN1 input on Side A.
OUT2	Logic Output 2 on Side B. OUT2 is the logic output for the IN2 input on Side A.
OUT3	Logic Output 3 on Side B/A. OUT3 is the logic output for the IN3 input on Side A/B.
OUT4	Logic Output 4 on Side B/A. OUT4 is the logic output for the IN4 input on Side A/B.
ENABLE INPUTS	
ENA	Active-High Enable for Side A. ENA has an internal 5μA pull-up to V _{DDA} .
$\overline{\text{ENA}}$	Active-Low Enable for Side A. $\overline{\text{ENA}}$ has an internal 5μA pull-down to GNDA.
ENB	Active-High Enable for Side B. ENB has an internal 5μA pull-up to V _{ddb} .
DEFAULT CONTROL	
DEFA	Default Control Input for Side A. Connect DEFA to V _{DDA} to set side A outputs to a default-high state and to enable the pullup current on side A inputs. Connect DEFA to GNDA to set side A outputs to a default-low state and enable the pulldown current on side A inputs. DEFA must be tied to the same state (high or low) as DEFB.
DEFB	Default Control Input for Side B. Connect DEFB to V _{ddb} to set side B outputs to a default-high state and to enable the pullup current on side B inputs. Connect DEFB to GNDB to set side B outputs to a default-low state and enable the pulldown current on side B inputs. DEFB must be tied to the same state (high or low) as DEFA.
INTERNALLY CONNECTED, NOT CONNECTED	
I.C.	Internally Connected. Leave unconnected or connect to GNDA or V _{DDA} .
N.C.	Not Connected. Not internally connected.

Functional Diagram

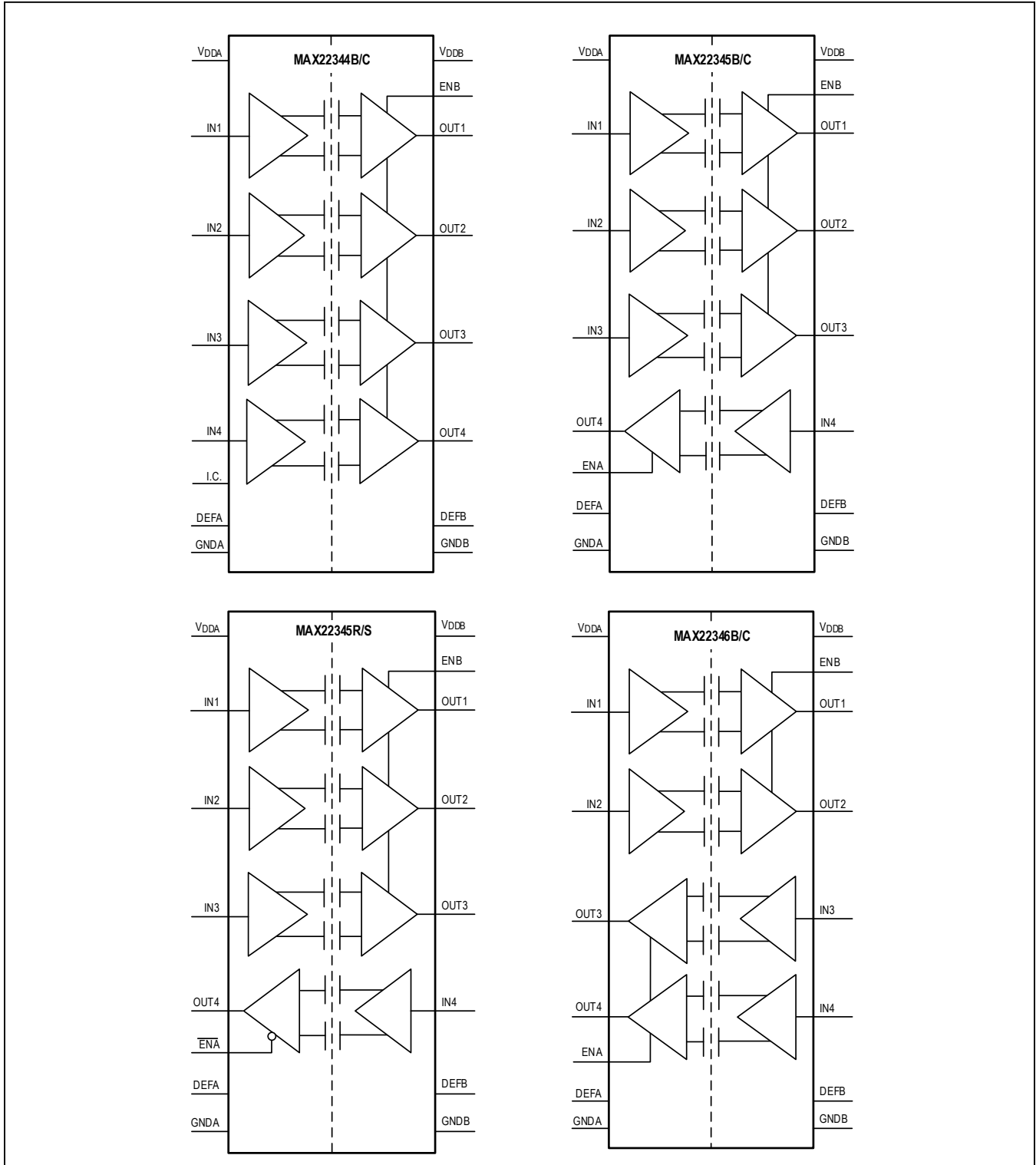

Detailed Description

The MAX22344–MAX22346 are a family of 4-channel reinforced digital isolators. The MAX22344–MAX22346 have an isolation rating of 3.75kV_{RMS}. The MAX22344–MAX22346 family offers all possible unidirectional channel configurations to accommodate any 4-channel design, including SPI, RS-232, RS-485, and digital I/O applications. For applications requiring bidirectional channels, such as I²C, see the MAX14933 and MAX14937.

The MAX22344 features four channels transferring digital signals in one direction for applications such as isolated digital I/O. The MAX22345 has three channels transmitting data in one direction and one channel transmitting in the opposite direction, making them ideal for applications such as isolated SPI and RS-485 communication. The MAX22346 provides further design flexibility with two channels in each direction for isolated RS-232 or other applications.

Devices are available in a 20-pin SSOP package and are rated for up to 3.75kV_{RMS}. This family of digital isolators offers low-power operation, high electromagnetic interference (EMI) immunity, and stable temperature performance through Maxim’s proprietary process technology. The devices isolate different ground domains and block high-voltage/high-current transients from sensitive or human interface circuitry.

Devices are available with a maximum data rate of either 25Mbps (B/R versions) or 200Mbps (C/S versions). All devices feature user-selectable default-high or default-low outputs. The default is the state the output assumes when the input is not powered or if the input is open-circuit. The devices have two supply inputs (V_{DDA} and V_{DDB}) that independently set the logic levels on either side of the device. V_{DDA} and V_{DDB} are referenced to GNDA and GNDB, respectively. The MAX22344–MAX22346 also feature a refresh circuit to ensure output accuracy when an input remains in the same state indefinitely.

Digital Isolation

The MAX22344–MAX22346 provide reinforced galvanic isolation for digital signals that are transmitted between two ground domains. The devices withstand differences of up to 3.75kV_{RMS} for up to 60 seconds, and up to 1108V_{PEAK} of continuous isolation.

Level-Shifting

The wide supply voltage range of both V_{DDA} and V_{DDB} allows the MAX22344–MAX22346 to be used for level translation in addition to isolation. V_{DDA} and V_{DDB} can be independently set to any voltage from 1.71V to 5.5V. The supply voltage sets the logic level on the corresponding side of the isolator.

Unidirectional Channels

Each channel of the MAX22344–MAX22346 is unidirectional; it only passes data in one direction, as indicated in the functional diagram. Each device features four unidirectional channels that operate independently with guaranteed data rates from DC up to 25Mbps (B/R versions), or from DC to 200Mbps (C/S versions). The output driver of each channel is push-pull, eliminating the need for pullup resistors. The outputs are able to drive both TTL and CMOS logic inputs.

Startup and Undervoltage-Lockout

The V_{DDA} and V_{DDB} supplies are both internally monitored for undervoltage conditions. Undervoltage events can occur during power-up, power-down, or during normal operation due to a sagging supply voltage. When an undervoltage condition is detected on either supply while the outputs are enabled, all outputs go to their default states regardless of the state of the inputs (Table 3, Table 4). Figure 5 through Figure 8 show the behavior of the outputs during power-up and power-down.

Table 3. MAX2234_B/C Output Behavior During Undervoltage Conditions

V _{IN_}	V _{DDA}	V _{DDB}	ENA	ENB	V _{OUTA}	V _{OUTB}
1	Powered	Powered	1	1	High	High
			0	0	Hi-Z	Hi-Z
0	Powered	Powered	1	1	Low	Low
			0	0	Hi-Z	Hi-Z
X	Undervoltage	Powered	1	1	Default	Default
			0	0	Hi-Z	Hi-Z
X	Powered	Undervoltage	1	1	Default	Default
			0	0	Hi-Z	Hi-Z

Table 4. MAX22345R/S Output Behavior During Undervoltage Conditions

V _{IN_}	V _{DDA}	V _{DDB}	$\overline{\text{ENA}}$	ENB	V _{OUTA}	V _{OUTB}
1	Powered	Powered	0	1	High	High
			1	0	Hi-Z	Hi-Z
0	Powered	Powered	0	1	Low	Low
			1	0	Hi-Z	Hi-Z
X	Undervoltage	Powered	0	1	Default	Default
			1	0	Hi-Z	Hi-Z
X	Powered	Undervoltage	0	1	Default	Default
			1	0	Hi-Z	Hi-Z

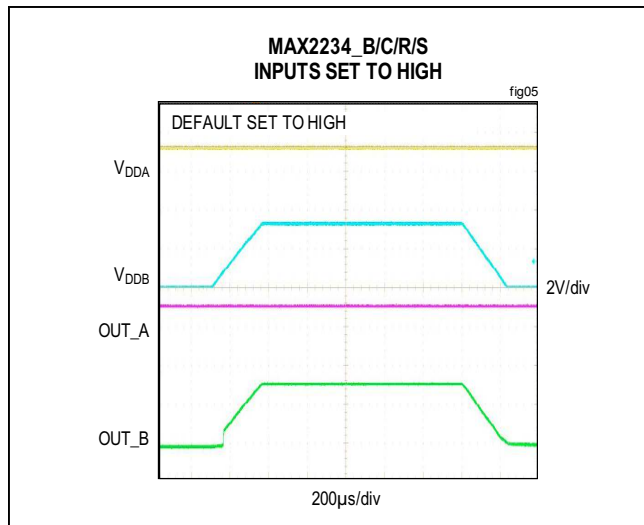

Figure 5. Undervoltage Lockout Behavior (MAX2234_High)

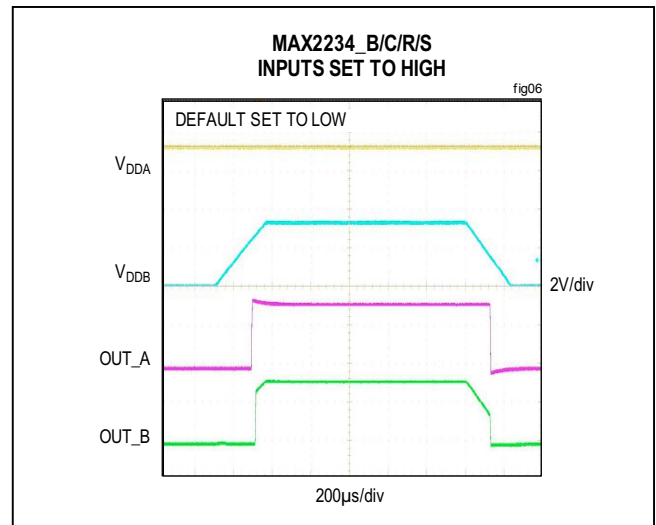

Figure 6. Undervoltage Lockout Behavior (MAX2234_Low)

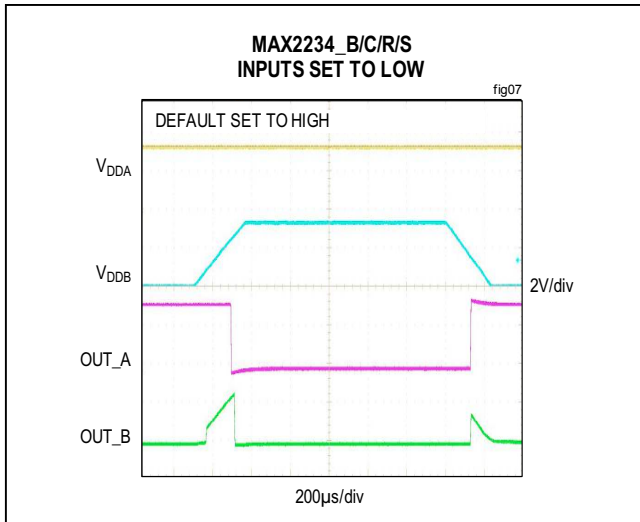

Figure 7. Undervoltage Lockout Behavior (MAX2234_Low)

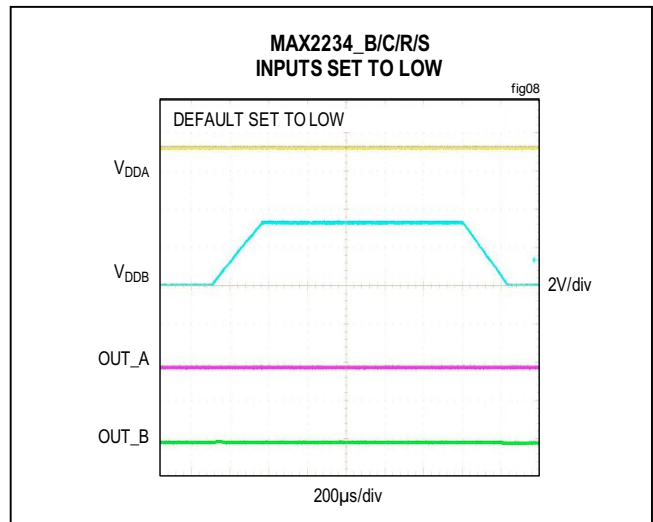

Figure 8. Undervoltage Lockout Behavior (MAX2234_Low)

Selectable Output Default (DEFA, DEFB)

The default is the state the output assumes when the input is not powered or if the input is open circuit. The MAX22344-MAX22346 feature user-selectable default-high or default-low outputs. Set both DEFA and DEFB high to set all channels to default-high, or set both DEFA and DEFB low to set all channels to default-low.

Ensure the logic state (high or low) of DEFA is the same as that for DEFB. Do not toggle DEFA or DEFB during normal operation.

Applications Information

Power-Supply Sequencing

The MAX22344-MAX22346 do not require special power supply sequencing. The logic levels are set independently on either side by V_{DDB} and V_{DDB}. Each supply can be present over the entire specified range regardless of the level or presence of the other supply.

Power-Supply Decoupling

To reduce ripple and the chance of introducing data errors, bypass V_{DDB} and V_{DDB} with 0.1µF low-ESR ceramic capacitors to GNDA and GNDB, respectively. Place the bypass capacitors as close to the power supply input pins as possible.

Layout Considerations

The PCB designer should follow some critical recommendations in order to get the best performance from the design.

- Keep the input/output traces as short as possible. To keep signal paths low-inductance, avoid using vias.
- Have a solid ground plane underneath the high-speed signal layer.
- Keep the area underneath the MAX22344-MAX22346 free from ground and signal planes. Any galvanic or metallic connection between the Side A and Side B defeats the isolation.

Calculating Power Dissipation

The required current for a given supply (V_{DDB} or V_{DDB}) can be estimated by summing the current required for each channel. The supply current for a channel depends on whether the channel is an input or an output, the channel's data rate, and the capacitive or resistive load if it is an output. The typical current for an input or output at any data rate can be estimated from the graphs in [Figure 9](#) and [Figure 10](#). Please note the data in [Figure 9](#) and [Figure 10](#) are extrapolated from the supply current measurements in a typical operating condition.

The total current for a single channel is the sum of the “no load” current (shown in [Figure 9](#) and [Figure 10](#)) which is a function of Voltage and Data Rate, and the “load current,” which depends on the type of load. Current into a capacitive load is a function of the load capacitance, the switching frequency, and the supply voltage.

$$I_{CL} = C_L \times f_{SW} \times V_{DD}$$

where

I_{CL} is the current required to drive the capacitive load.

C_L is the load capacitance on the isolator's output pin.

f_{SW} is the switching frequency (bits per second/2).
 V_{DD} is the supply voltage on the output side of the isolator.
 Current into a resistive load depends on the load resistance, the supply voltage and the average duty cycle of the data waveform. The DC load current can be conservatively estimated by assuming the output is always high.

$$I_{RL} = V_{DD} \div R_L$$

where

I_{RL} is the current required to drive the resistive load.
 V_{DD} is the supply voltage on the output side of the isolator.
 R_L is the load resistance on the isolator's output pin.

Example (shown in [Figure 11](#)): A MAX22345C is operating with $V_{DDA} = 2.5V$, $V_{DDB} = 3.3V$, channel 1 operating at 20Mbps with a 10pF capacitive load, channel 2 held high with a 10kΩ resistive load, and channel 4 operating at 100Mbps with a 15pF capacitive load. Channel 3 is not in use and the resistive load is negligible since the isolator is driving a CMOS input. Refer to [Table 5](#) and [Table 6](#) for V_{DDA} and V_{DDB} supply current calculation worksheets.

V_{DDA} must supply:

- Channel 1 is an input channel operating at 2.5V and 20Mbps, consuming 0.33mA, estimated from [Figure 9](#).

- Channel 2 and 3 are input channels operating at 2.5V with DC signal, consuming 0.14mA, estimated from [Figure 9](#).
- Channel 4 is an output channel operating at 2.5V and 100Mbps, consuming 0.77mA, estimated from [Figure 10](#).
- I_{CL} on channel 4 for 15pF capacitor at 2.5V and 100Mbps is 1.875mA.

Total current for side A = $0.33 + 0.14 \times 2 + 0.77 + 1.875 = 3.255mA$, typical

V_{DDB} must supply:

- Channel 1 is an output channel operating at 3.3V and 20Mbps, consuming 0.40mA, estimated from [Figure 10](#).
- Channel 2 and 3 are output channels operating at 3.3V with DC signal, consuming 0.27mA, estimated from [Figure 10](#).
- Channel 4 is an input channel operating at 3.3V and 100Mbps, consuming 1.11mA, estimated from [Figure 9](#).
- I_{CL} on channel 1 for 10pF capacitor at 3.3V and 20Mbps is 0.33mA.
- I_{RL} on channel 2 for 10kΩ resistor held at 3.3V is 0.33mA.

Total current for side B = $0.40 + 0.27 \times 2 + 1.11 + 0.33 + 0.33 = 2.71mA$, typical

Table 5. Side A Supply Current Calculation Worksheet

SIDE A		$V_{DDA} = 2.5V$				
Channel	IN/OUT	Data Rate (Mbps)	Load Type	Load	"No Load" Current (mA)	Load Current (mA)
1	IN	20			0.33	
2	IN	0			0.14	
3	IN	0			0.14	
4	OUT	100	Capacitive	15pF	0.77	$2.5V \times 50MHz \times 15pF = 1.875mA$
Total: 3.26mA						

Table 6. Side B Supply Current Calculation Worksheet

SIDE B		$V_{DDB} = 3.3V$				
Channel	IN/OUT	Data Rate (Mbps)	Load Type	Load	"No Load" Current (mA)	Load Current (mA)
1	OUT	20	Capacitive	10pF	0.40	$3.3V \times 10MHz \times 10pF = 0.33mA$
2	OUT	0	Resistive	10kΩ	0.27	$3.3V / 10k\Omega = 0.33mA$
3	OUT	0			0.27	
4	IN	100			1.11	
Total: 2.71mA						

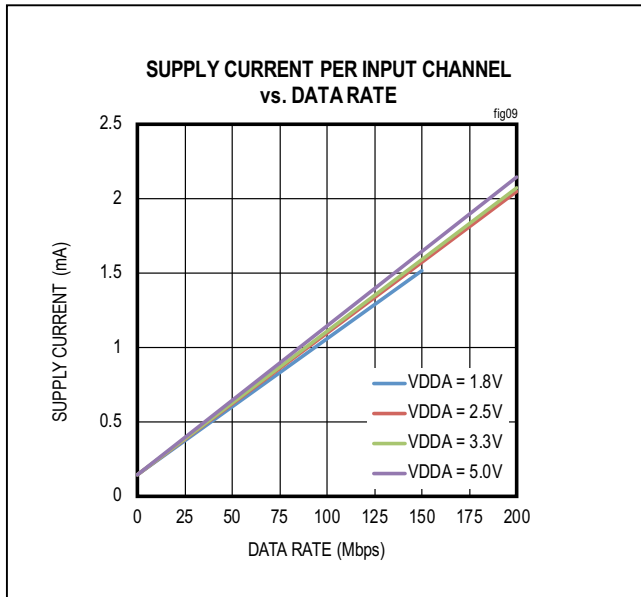

Figure 9. Supply Current Per Input Channel (Estimated)

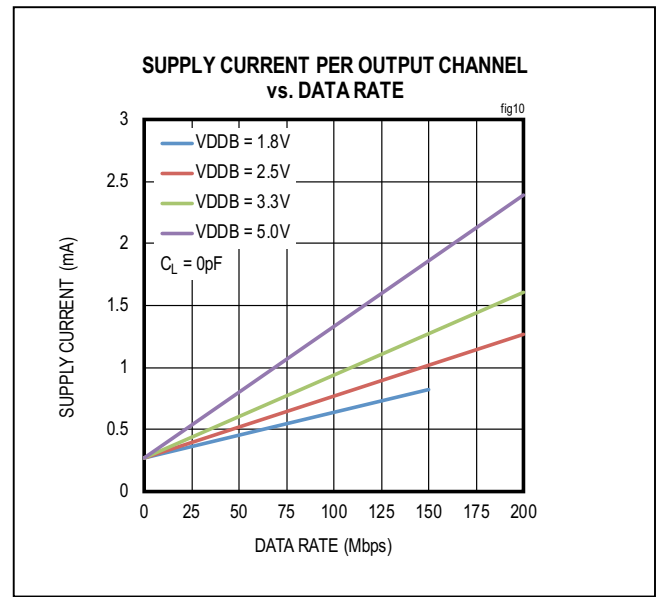

Figure 10. Supply Current Per Output Channel (Estimated)

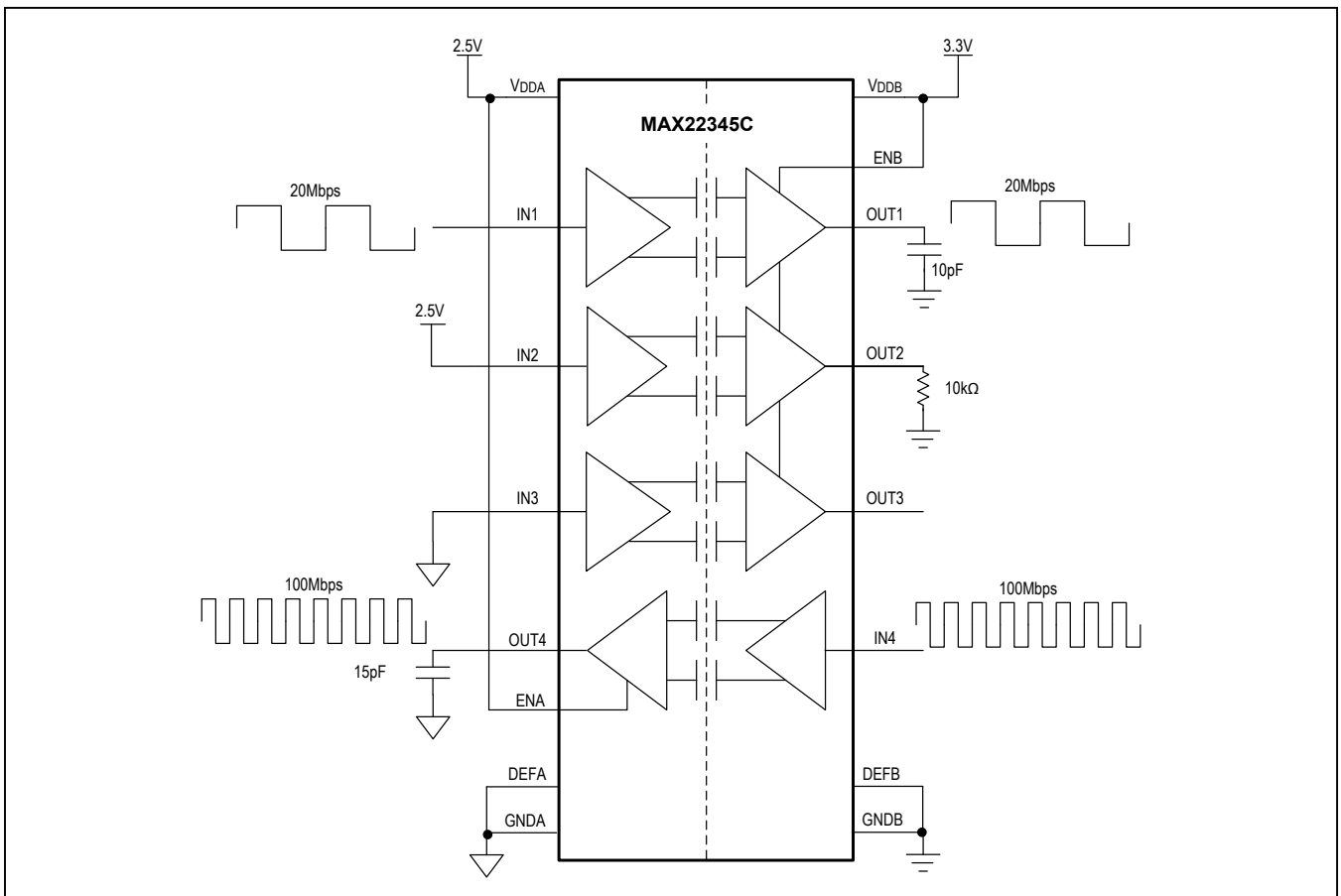
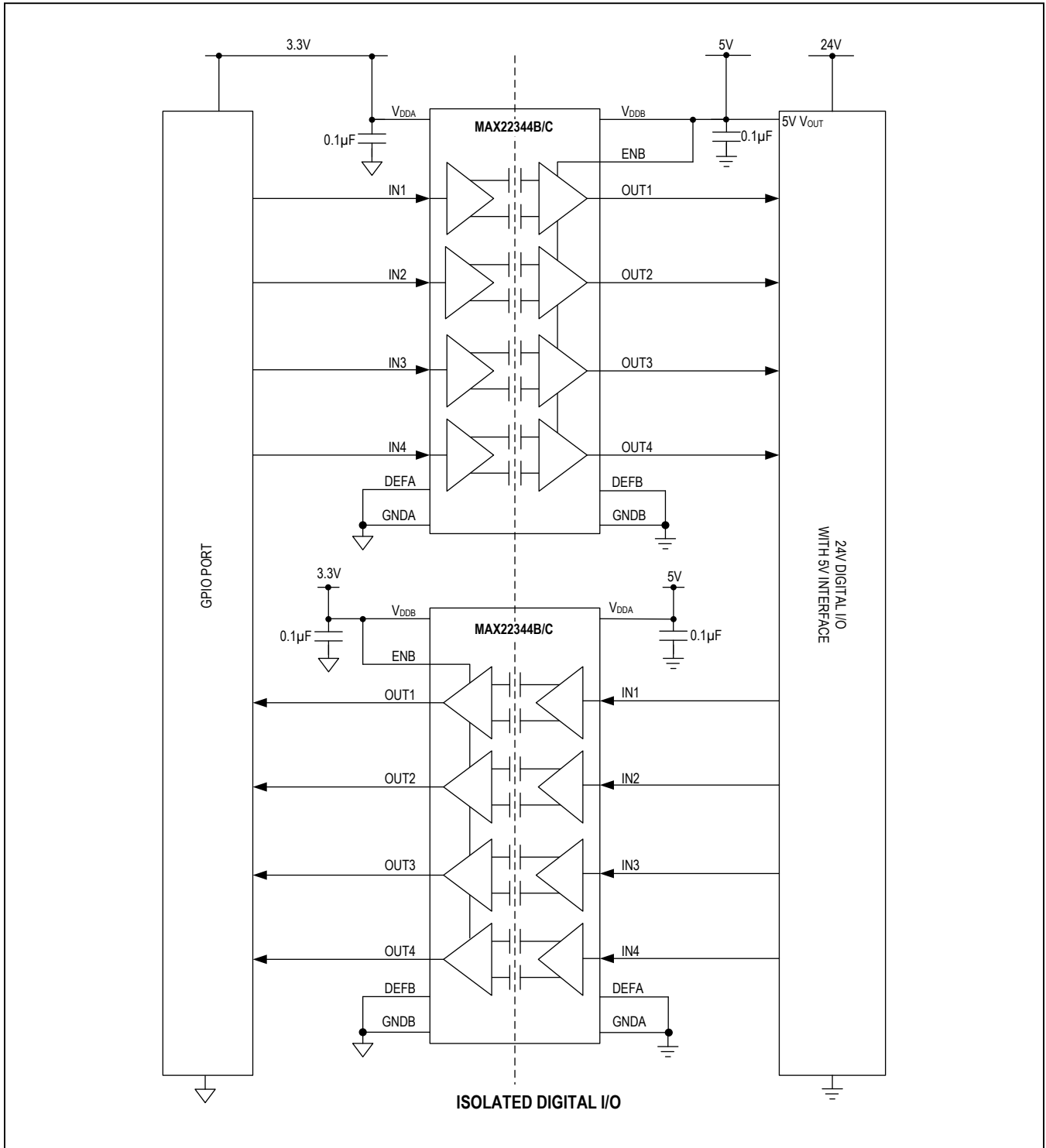
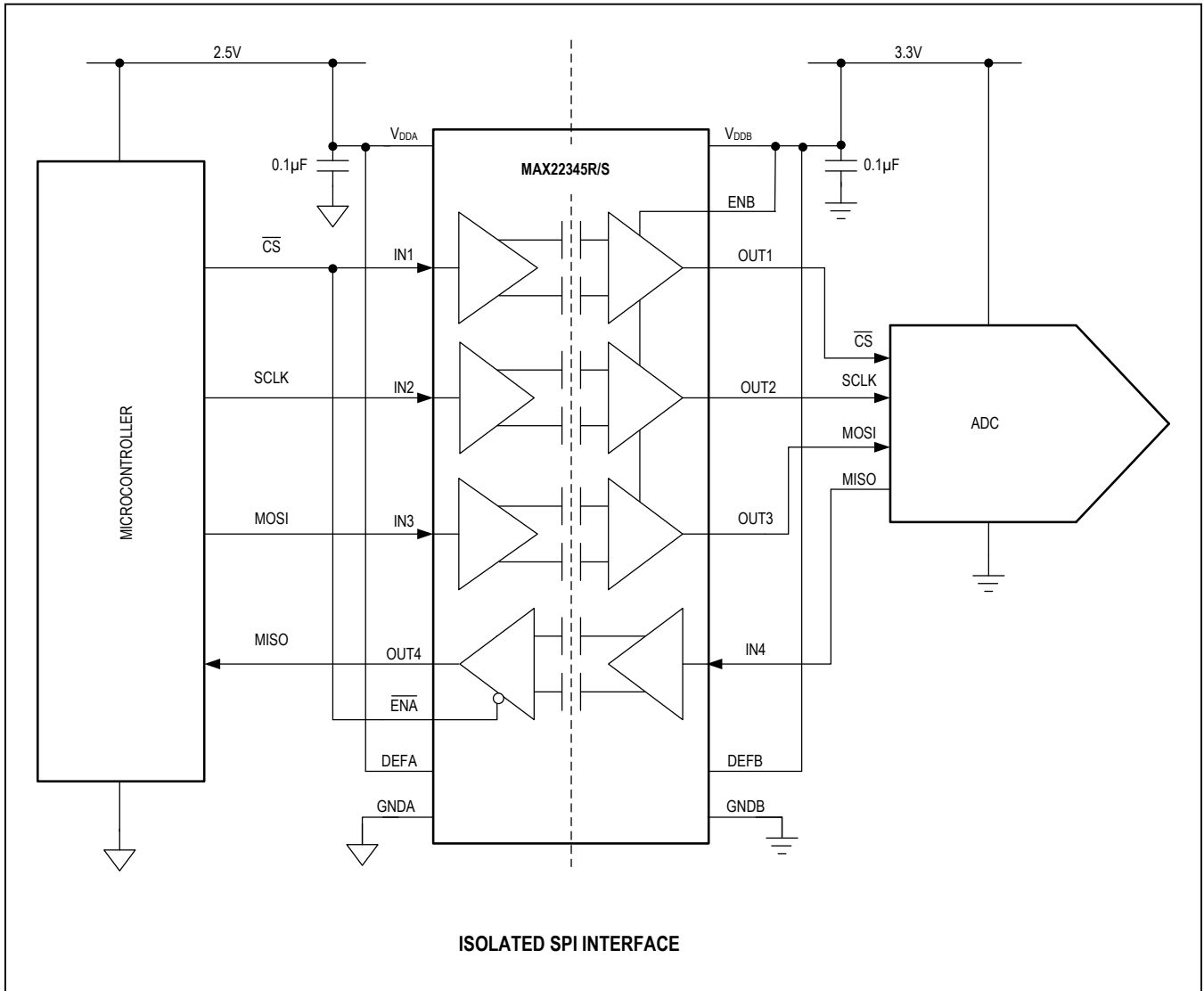

Figure 11. Example Circuit for Supply Current Calculation

Typical Operating Circuits



Typical Operating Circuits (continued)



Typical Operating Circuits (continued)

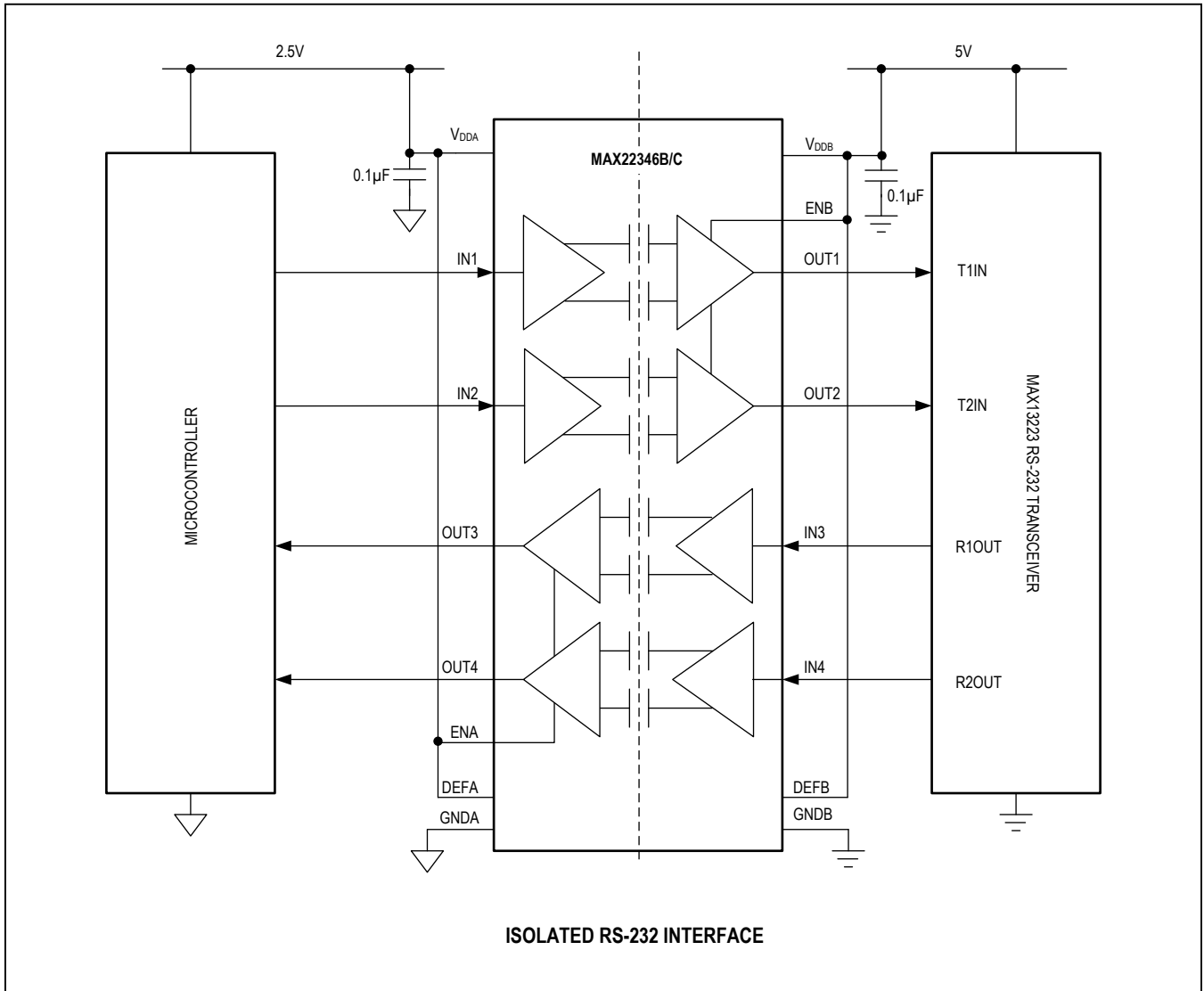

Product Selector Guide

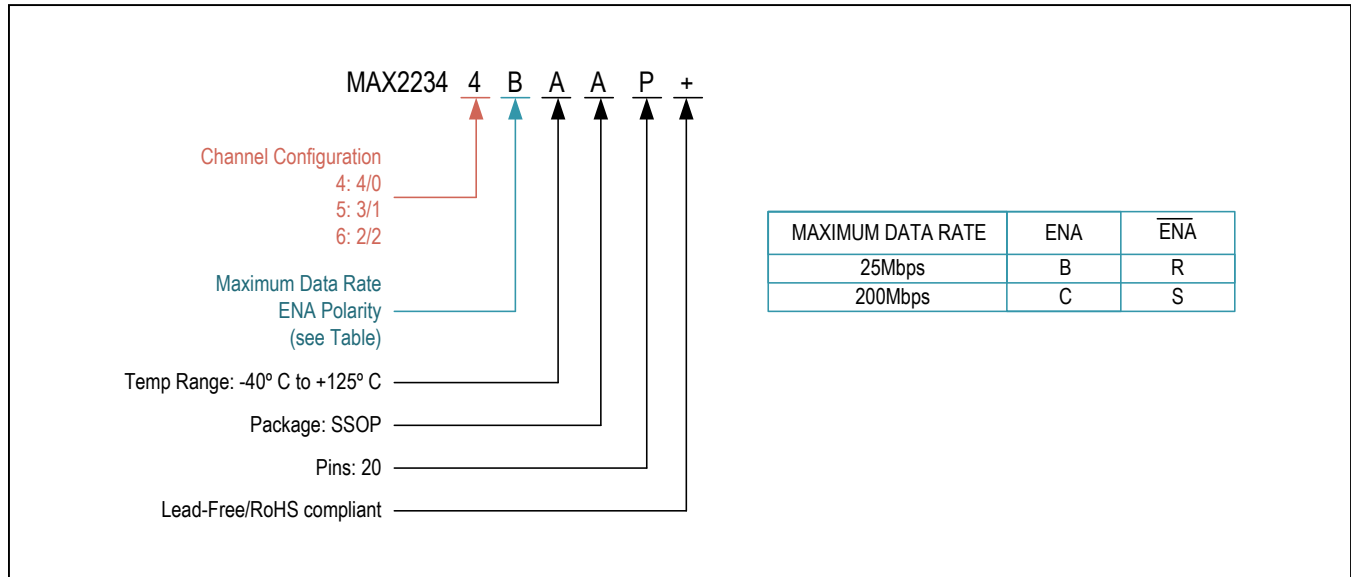

Ordering Information

PART	CHANNEL CONFIGURATION	DATA RATE (Mbps)	ENA POLARITY	ISOLATION VOLTAGE (kV _{RMS})	TEMP RANGE (°C)	PIN-PACKAGE
MAX22344 BAAP+*	4/0	25	–	3.75	-40 to +125	20 SSOP
MAX22344CAAP+	4/0	200	–	3.75	-40 to +125	20 SSOP
MAX22345 BAAP+*	3/1	25	Active-High	3.75	-40 to +125	20 SSOP
MAX22345CAAP+*	3/1	200	Active-High	3.75	-40 to +125	20 SSOP
MAX22345RAAP+*	3/1	25	Active-Low	3.75	-40 to +125	20 SSOP
MAX22345SAAP+	3/1	200	Active-Low	3.75	-40 to +125	20 SSOP
MAX22346 BAAP+*	2/2	25	Active-High	3.75	-40 to +125	20 SSOP
MAX22346CAAP+	2/2	200	Active-High	3.75	-40 to +125	20 SSOP

*Future product—contact factory for availability.

+Denotes a lead(Pb)-free/RoHS-compliant package.

Chip Information

PROCESS: BiCMOS

Revision History

REVISION NUMBER	REVISION DATE	DESCRIPTION	PAGES CHANGED
0	2/18	Initial release	—
1	10/18	Updated title, added future product designation to MAX22344CAAP+ and removed it from MAX22345SAAP+ in the <i>Ordering Information</i> table.	1–30
2	2/19	Removed future product designation from MAX22344CAAP+ in the <i>Ordering Information</i> table.	30
3	3/19	Removed future product designation from MAX22346CAAP+ in the <i>Ordering Information</i> table.	30

For pricing, delivery, and ordering information, please visit Maxim Integrated's online storefront at <https://www.maximintegrated.com/en/storefront/storefront.html>.

Maxim Integrated cannot assume responsibility for use of any circuitry other than circuitry entirely embodied in a Maxim Integrated product. No circuit patent licenses are implied. Maxim Integrated reserves the right to change the circuitry and specifications without notice at any time. The parametric values (min and max limits) shown in the Electrical Characteristics table are guaranteed. Other parametric values quoted in this data sheet are provided for guidance.