

THIS DRAWING IS UNPUBLISHED. RELEASED FOR PUBLICATION
 © COPYRIGHT 2010 BY TYCO ELECTRONICS CORPORATION. ALL RIGHTS RESERVED.

LOC		DIST		REVISIONS			
P	LTR	DESCRIPTION		DATE	DWN	APVD	
	B	OBSELETE		08JAN16	H.X	W.H	

- NOTE:
- MATERIAL:
 HOUSING: PA6T WITH 30% GF, UL 94V-0, NATURAL COLOR.
 ACTUATOR: PPS WITH 45% GF, UL 94V-0, BLACK COLOR.
 CONTACTS: PHOSPHOR BRONZE.
 PEGS: PHOSPHOR BRONZE.
 - FINISH:
 CONTACTS: 0.0762µm [3µ"] MIN. GOLD PLATED ON CONTACT AREA, GOLD FLASH ON SOLDER TAIL, WITH ENTIRE CONTACT UNDERPLATED 1.27µm [50µ"] MIN. NICKEL
 PEGS: 2.54µm [100µ"] MIN. MATTE-TIN OVER 1.27µm [50µ"] MIN. NICKEL
 - REFLOW SOLDER CAPABLE TO 260°C AS PER TE SPEC. 109-201, CONDITION B.
 - SUBSTANCE RESTRICTIONS FOR LOW HALOGEN (BY WEIGHT):
 BROMINE (Br) ≤ 900 PPM (0.09%)
 CHLORINE (Cl) ≤ 900 PPM (0.09%)
 TOTAL CONCENTRATION OF CHLORINE (Cl) + BROMINE (Br) ≤ 1500 PPM (0.15%)

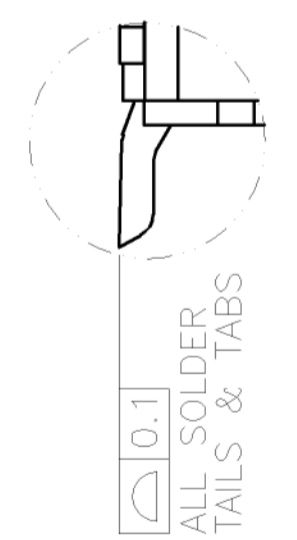
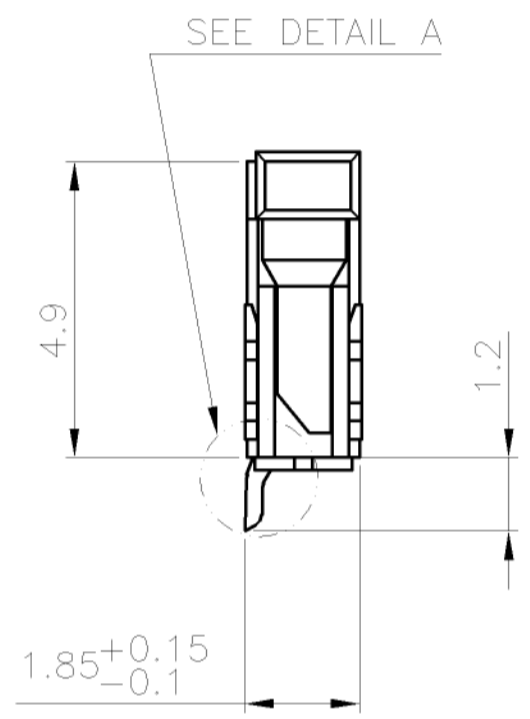
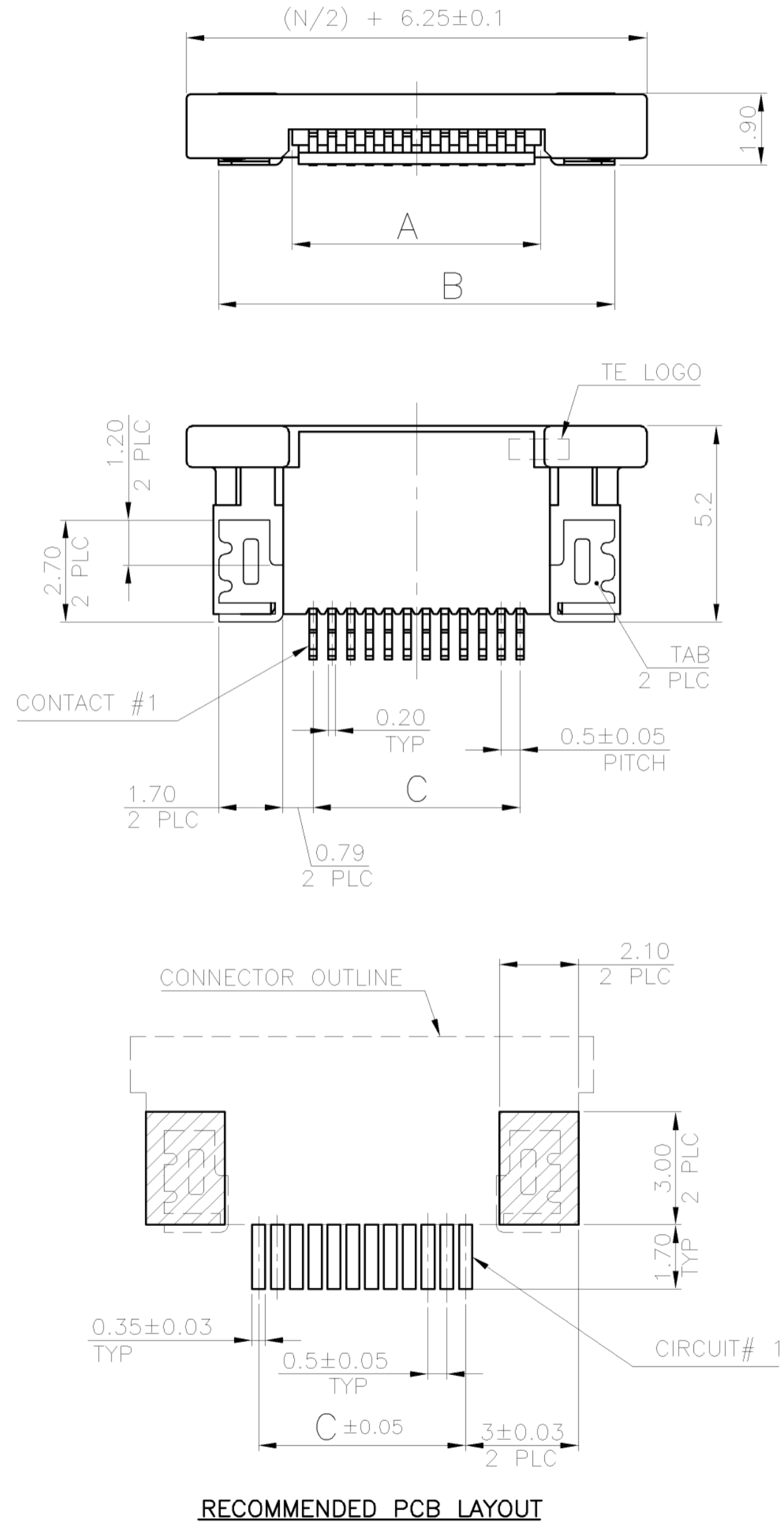

DETAIL A

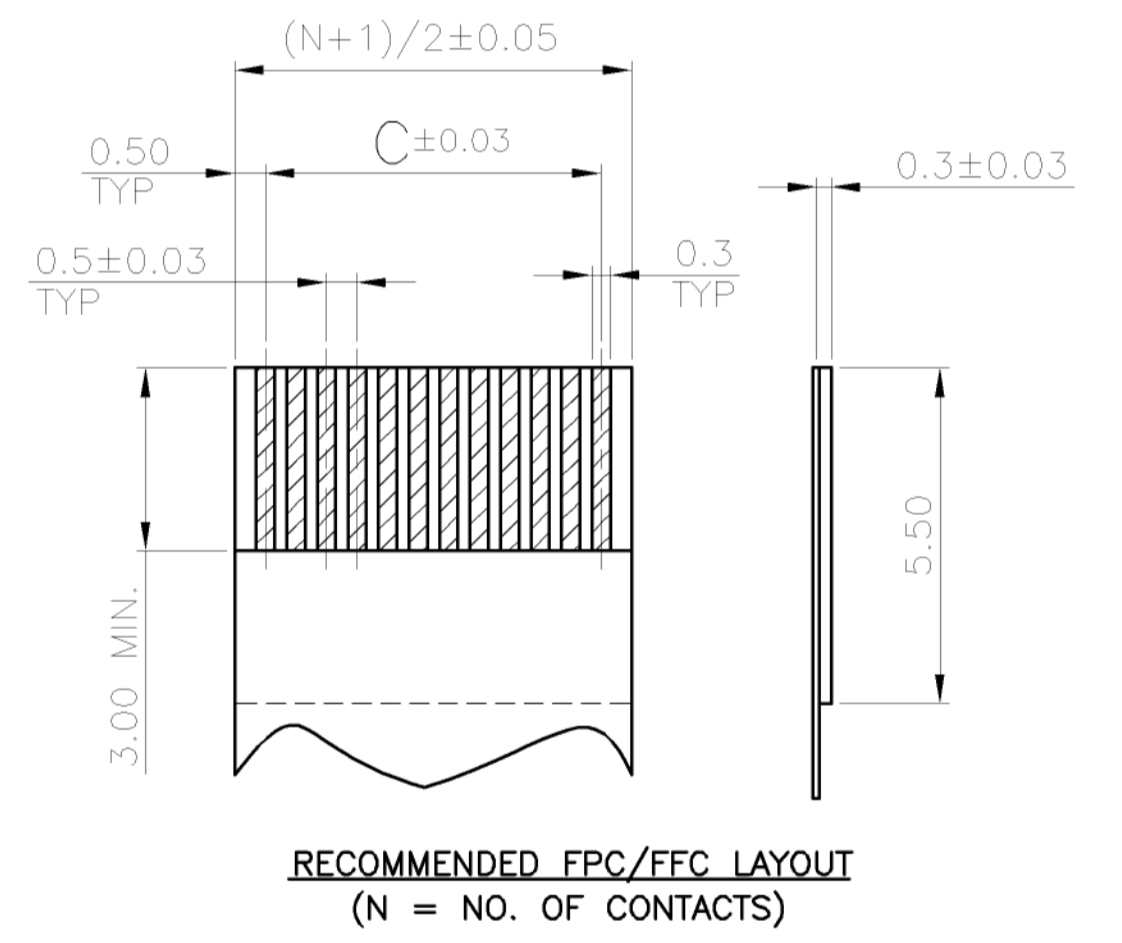
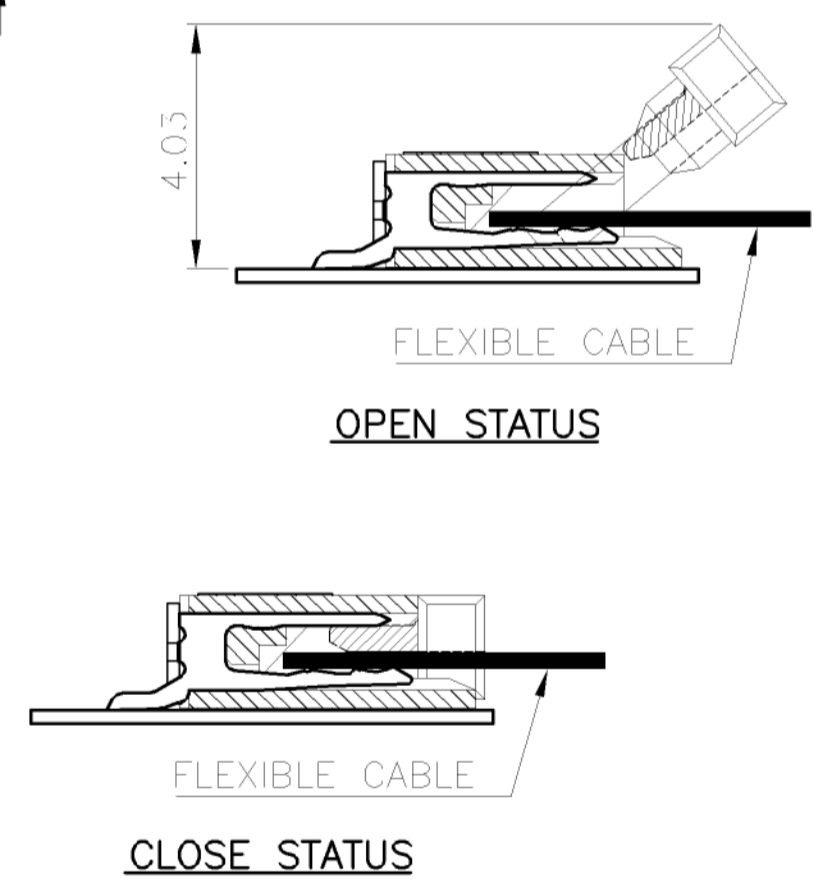

OBSELETE

WEIGHT (GRAMS)	DIMENSIONS			NO. OF CONTACTS	PART NUMBER
0.21	5.5	10.51	6.60	12	1-2041324-2

THIS DRAWING IS A CONTROLLED DOCUMENT.		DWN A. WU	03NOV2010	Tyco Electronics Corporation Taipei, Taiwan	
DIMENSIONS: MM		CHK S. CHIEN	03NOV2010	NAME	
TOLERANCES UNLESS OTHERWISE SPECIFIED:		APVD W. KODAMA	03NOV2010	FPC CONNECTOR, 0.5 MM PITCH, ZIF, BOTTOM CONTACT	
0 PLC ± -	1 PLC ± 0.25	PRODUCT SPEC		SIZE	CAGE CODE
2 PLC ± 0.2	3 PLC ± -	108-57364		A3	00779
4 PLC ± -	ANGLES ± -	APPLICATION SPEC		DRAWING NO	C=2041324
MATERIAL SEE NOTE	FINISH SEE NOTE	WEIGHT SEE TABLE		RESTRICTED TO	
CUSTOMER DRAWING		SCALE -		SHEET 1 OF 2	REV B

THIS DRAWING IS UNPUBLISHED. RELEASED FOR PUBLICATION
 © COPYRIGHT 2010 BY TYCO ELECTRONICS CORPORATION. ALL RIGHTS RESERVED.

LOC DW	DIST —	REVISIONS			
P	LTR	DESCRIPTION	DATE	DWN	APVD
		SEE SHEET 1			

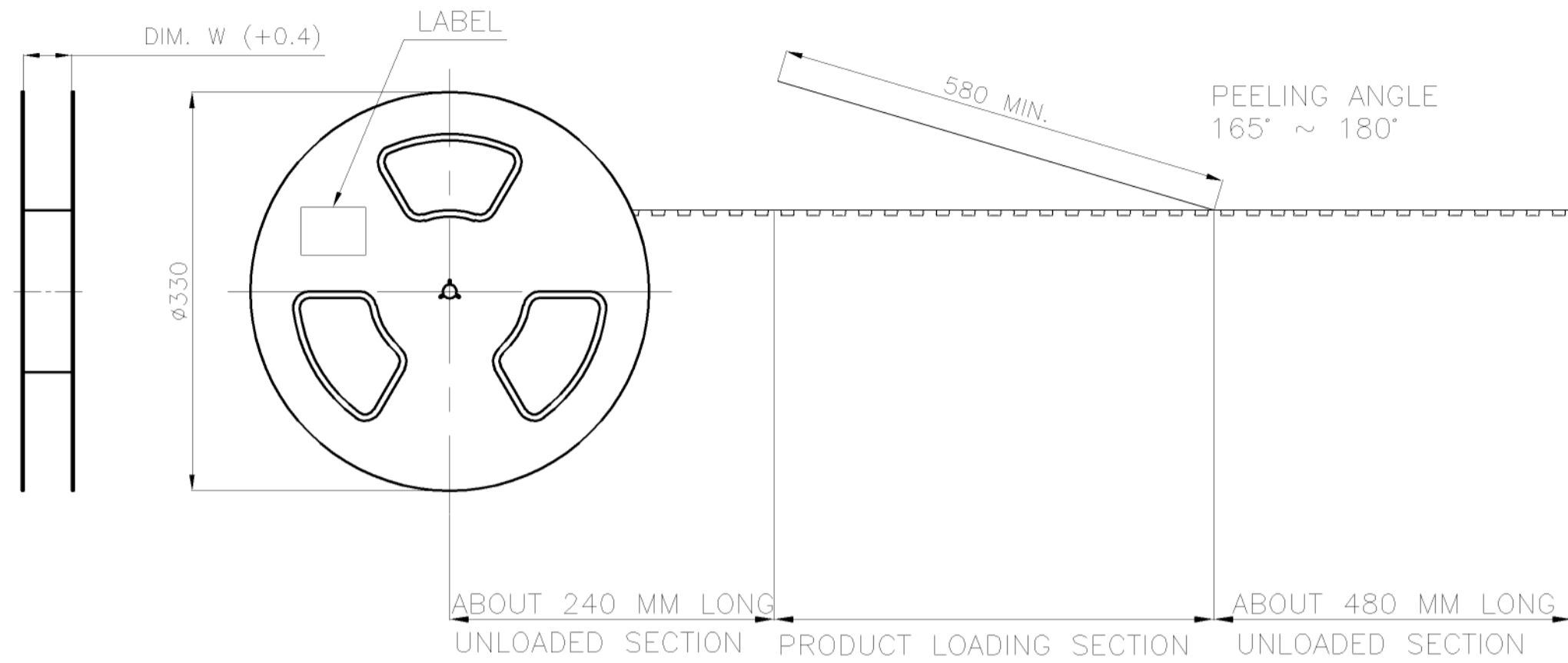

NOTES:

- MATERIAL:
 BOX: FIBREBOARD, CORRUGATED, DOUBLE WALL.
 COVER TAPE: PET, TRANSPARENT COLOR.
 CARRIER TAPE: POLYSTYRENES, TRANSPARENT COLOR.
 REEL: HIPS, BLUE COLOR.
 BAG: POLYETHYLENES, TRANSPARENT COLOR.
- EACH BAG SHALL BE INCLUDED DESICCANT.
- PEELING STRENGTH: 0.1 ~ 1.3 N (10 ~ 130 GRAMS).
- PEELING SPEED: 300 mm/min.

USER DIRECTION OF UNREELING →

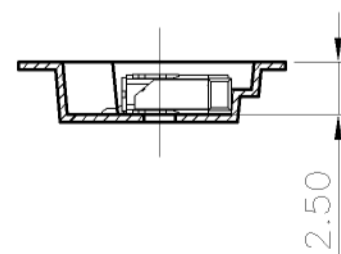
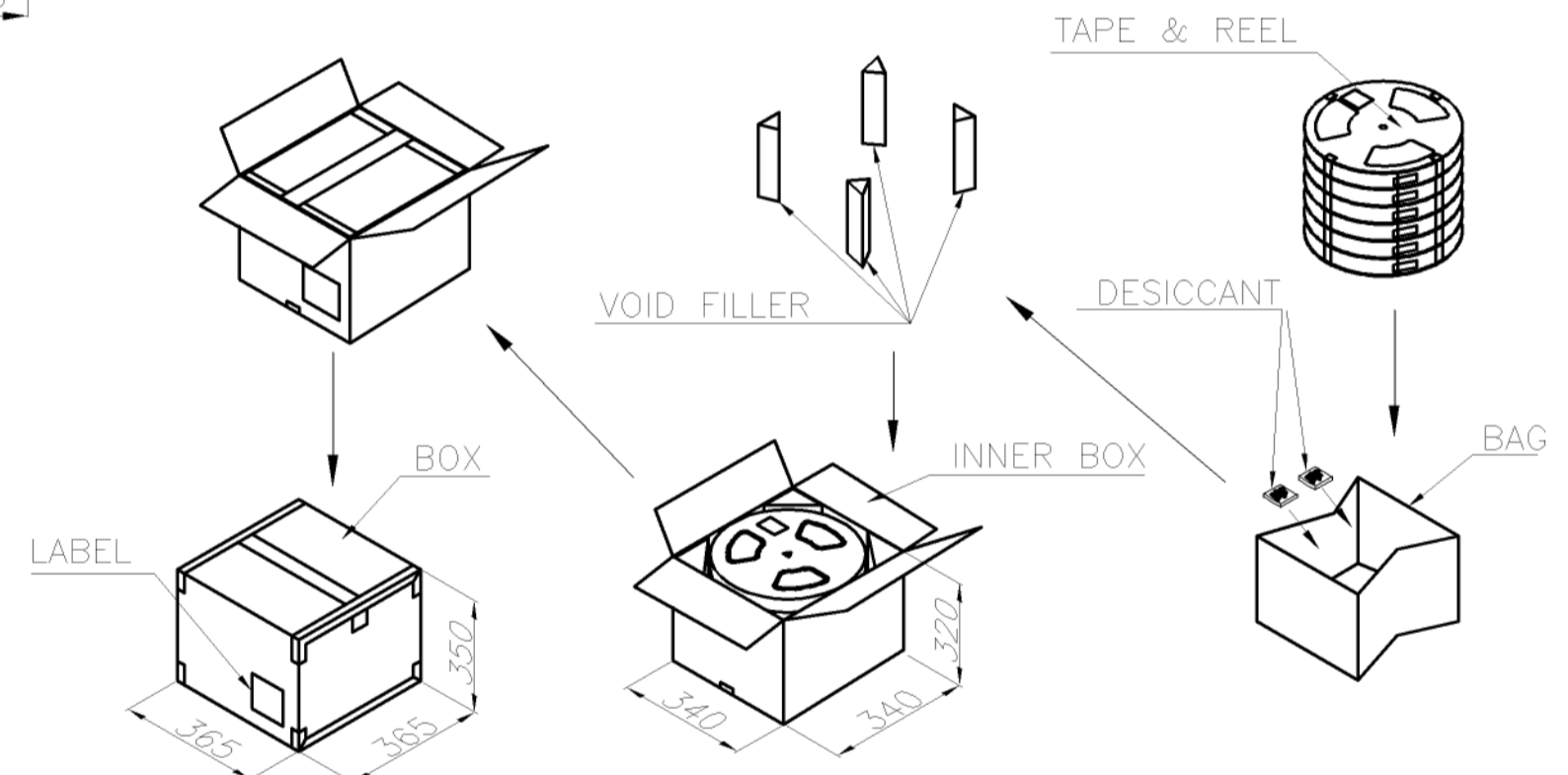
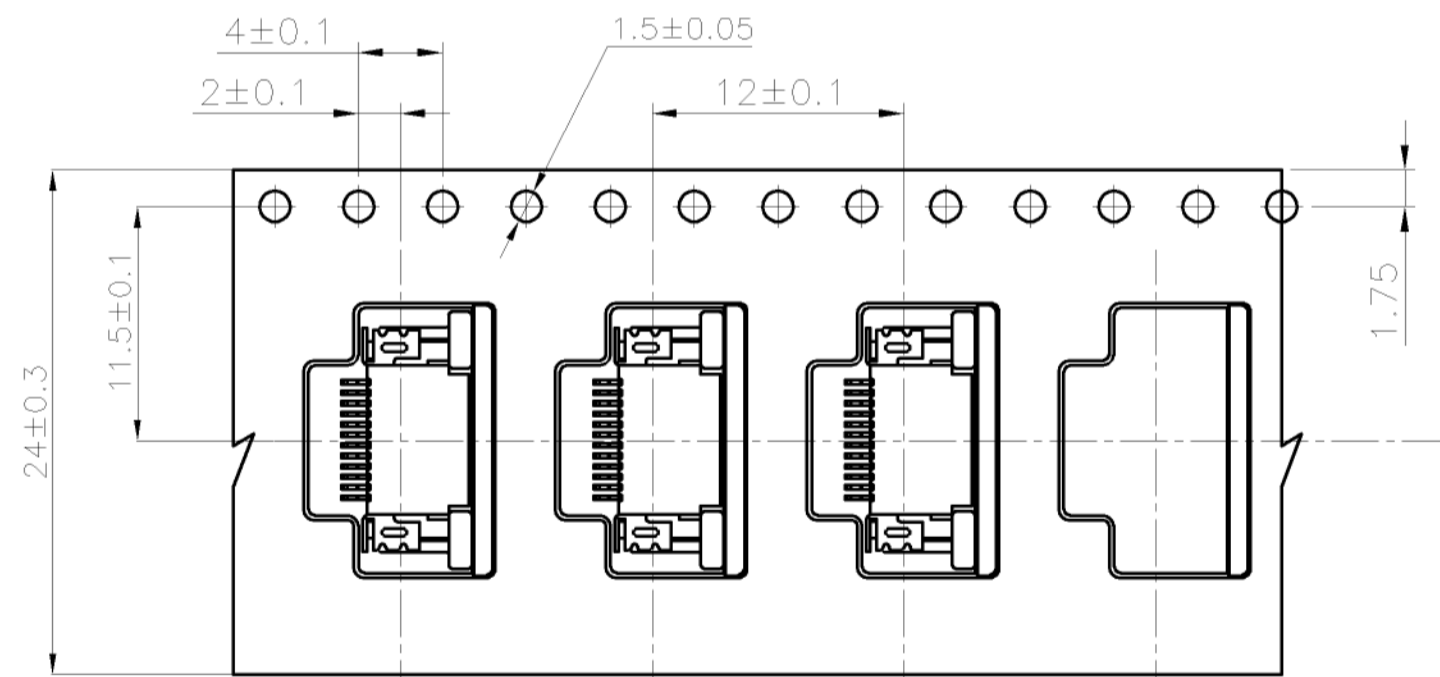

20000	2000	10	8.4	4.2	12
QUANTITY	PCS/TAPE	REELS/BOX	G/W (Kg)	N/W (Kg)	NO. OF CONTACTS

THIS DRAWING IS A CONTROLLED DOCUMENT.		DWN A. WU 03NOV2010	Tyco Electronics Corporation Taipei, Taiwan		
DIMENSIONS: MM		CHK S. CHIEN 03NOV2010	NAME		
TOLERANCES UNLESS OTHERWISE SPECIFIED:		APVD W. KODAMA 03NOV2010	FPC CONNECTOR, 0.5 MM PITCH, ZIF, BOTTOM CONTACT		
0 PLC ± -		PRODUCT SPEC	SIZE	CAGE CODE	DRAWING NO
1 PLC ± -		—	A3	00779	C=2041324
2 PLC ± -		APPLICATION SPEC	RESTRICTED TO		
3 PLC ± -		—	—		
4 PLC ± -		WEIGHT	—		
ANGLES ± -		CUSTOMER DRAWING	SCALE	SHEET	REV
FINISH		—	—	2 OF 2	B